

SPRINTER

BODY BUILDER INFORMATION BOOK

Model series 906

Date of publication:

June 7th, 2012



Table of Contents

Alterations	1	2.5. Vehicle Identification Number (VIN) Coding Summary	15
Revised	1	2.6. Labels	17
1. Introduction	2	2.7. Granting of body technical assistance...	19
1.1. The aim of the Body Builder Information Book	2	2.8. Body builder responsibilities	19
1.2. Vehicle Safety	3	2.9. Vehicle rollover stability information	20
1.3. Operating Safety	3	3. Planning of Bodies.....	21
1.4. Regulatory Requirements:	4	3.1. Selecting the chassis	21
1.5. Definitions	5	3.1.1. Selecting the suspension package	21
1.6. Warranty and Vehicle Safe Operation:	5	3.2. Vehicle modifications	22
2. General	6	3.3. Dimensions and weights.....	23
2.1. Emissions and safety information	6	3.4. Vehicle type identification date	24
2.1.1. Vehicle noise emission control information	6	3.5. Tires	25
2.1.2. Exhaust emission control information	7	3.6. Bolted and welded connections.....	26
2.2. Vehicle safety standards information	8	3.6.1. Bolted connections	26
2.2.1. FMVSS 101/CMVSS 101	8	3.6.2. Welded connections	26
2.2.2. FMVSS 102/CMVSS 102	8	3.7. Noise Insulation	29
2.2.3. FMVSS 103/CMVSS 103	8	3.8. Maintenance and repairs	29
2.2.4. FMVSS 104/CMVSS 104	8	3.8.1. Storing the vehicle	30
2.2.5. FMVSS 105/CMVSS 105	8	3.8.2. Battery maintenance and storage	30
2.2.6. FMVSS 106/CMVSS 106	8	3.8.3. Work before delivering the modified vehicle.....	31
2.2.7. FMVSS 108/CMVSS 108	8	3.9. Optional Equipment	31
2.2.8. FMVSS 110/CMVSS 110	8	4. Technical limiting values for planning....	32
2.2.9. FMVSS 111/CMVSS 111	9	4.1. Limiting values of the basic vehicle	32
2.2.10. FMVSS 113/CMVSS 113	9	4.1.1. Maneuverability	32
2.2.11. FMVSS 114/CMVSS 114	9	4.1.2. Extreme permissible positions of center of gravity	32
2.2.12. FMVSS 116/CMVSS 116	9	4.1.3. Center of gravity Chassis Cab.....	32
2.2.13. FMVSS 118/CMVSS 118	9	4.1.4. Vehicle dimensions Chassis Cab	32
2.2.14. FMVSS 119/CMVSS 119	9	4.2. Chassis limiting values	33
2.2.15. FMVSS 120/CMVSS 120	9	4.2.1. Permissible axle loads	33
2.2.16. FMVSS 124/CMVSS 124	9	4.2.2. Approved tire sizes	33
2.2.17. FMVSS 201/CMVSS 201	9	4.2.3. Diameter of turning circle.....	33
2.2.18. FMVSS 202/CMVSS 202	9	4.2.4. Modifications to the Axles.....	33
2.2.19. FMVSS 203/CMVSS 203	10	4.2.5. Modifications to the steering system	33
2.2.20. FMVSS 204/ CMVSS 204	10	4.2.6. Modifications to the brake system	33
2.2.21. FMVSS 205/ CMVSS 205	10	4.2.7. Modifications to springs, spring mountings/shock absorbers.....	33
2.2.22. FMVSS 206/ CMVSS 206	10	4.2.8. Wheel alignment.....	33
2.2.23. FMVSS 207/CMVSS 207	10	4.3. Body shell limiting values	34
2.2.24. FMVSS 208/ CMVSS 208	10	4.3.1. Modifications to the body shell	34
2.2.25. FMVSS 209/ CMVSS 209	10	4.3.2. Limiting values of the vehicle frame	34
2.2.26. FMVSS 210/ CMVSS 210	10	4.3.3. Vehicle overhang.....	34
2.2.27. FMVSS 212/ CMVSS 212	10	4.3.4. Attachment points on the frame	34
2.2.28. FMVSS 214/CMVSS 214	10	4.3.5. Vehicle roof/roof load.....	34
2.2.29. FMVSS 219/ CMVSS 219	11	4.4. Modifications of engine peripherals / drive train	35
2.2.30. FMVSS 220/ CMVSS 220	11	4.4.1. Fuel system	35
2.2.31. FMVSS 301/ CMVSS 301	11	4.4.2. Modifications to the engine/drive train components	35
2.2.32. FMVSS 302/CMVSS 302	11	4.4.3. Engine cooling system.....	35
2.3. Vehicle and model designations	12	4.5. Modification to the interior	35
2.4. Vehicle and model designation	13		

4.5.1.	Modifications to airbags and belt tensions	35	6.7.	Electronic ignition switch (EZS)	65
4.5.2.	Modifications to seats	35	6.7.1.	General Information	65
4.6.	Limits to Electrics / Electronics	36	6.7.2.	Central locking/rescue vehicle	65
4.6.1.	Vehicle Marker and Clearance lamps	36	6.8.	Windows and doors	66
4.6.2.	Retrofitting electrical equipment	36	6.8.1.	Power windows/window hinges	66
4.6.3.	Mobile communication systems	36	6.8.2.	Load compartment sliding door	66
4.6.4.	CAN bus	36	6.8.3.	Sliding sunroof	67
4.6.5.	Electronic Stability Program	36	6.8.4.	Windscreen wipers	67
4.7.	Design Limits for additional equipment	36	6.8.5.	Exterior mirrors	67
4.8.	Design Limits for attachments	36	6.8.6.	Windscreen heating/rear window heating	67
4.9.	Design Limits for the body	37	6.9.	Electronic Stability Program (ESP)	67
4.9.1.	Design Limits of the mounting frame	37	6.10.	Signal acquisition and actuation module (SAM)	68
5.	Damage prevention	38	6.11.	Parametric special module (PSM)	69
5.1.	Brake hoses / cables and lines	38	6.11.1.	Inputs/Outputs	70
5.2.	Welding Work	38	6.11.2.	Parameterization with Logic Blocks	70
5.3.	Corrosion protection	40	6.11.3.	Contacts and pin allocation	71
5.4.	Painting work	42	6.11.4.	PSM signals	72
5.5.	Towing	42	6.12.	Tire pressure monitoring system	74
5.6.	Storing and delivery of the vehicle	42	6.13.	Parktronic	75
6.	Electrics/Electronics	43	6.14.	Lifting platform connection	Error!
6.1.	General Information	43			Bookmark not defined.
6.2.	Electromagnetic compatibility (EMC)	43	6.15.	Rain / light sensor	75
6.3.	Battery	44	7.	Modifications to the basic vehicle	76
6.3.1.	Auxiliary battery retrofit guidelines	45	7.1.1.	General information on the suspension	76
6.3.2.	Retrofitting an additional battery	49	7.1.2.	Springs/shock absorbers/anti-roll bars	77
6.3.3.	Battery maintenance and storage	49	7.1.3.	Brake system	78
6.3.4.	Alternator	49	7.1.4.	Wheels and tires	79
6.4.	Interfaces	51	7.1.5.	Spare wheel	79
6.4.1.	CAN bus and networking	51	7.2.	Body shell / Body	80
6.4.2.	Electric wiring/fuses	52	7.2.1.	General information on the body shell/body	80
6.4.3.	Additional power circuits	52	7.2.2.	Attachment to the frame	83
6.4.4.	Control Switches	52	7.2.3.	Chassis frame material	87
6.4.5.	Retrofitting electrical equipment	53	7.2.4.	Overhang extension	87
6.4.6.	Retrofitting an alternator	53	7.2.5.	Side wall, windows, doors and flaps	90
6.4.7.	Power supply	54	7.2.6.	End frame cross member	91
6.4.8.	Power supply Aux Battery	55	7.2.7.	Roof structure	91
6.4.9.	Speed Signal	56	7.2.8.	Tire Clearance Chassis-Cab	92
6.4.10.	Ground Connections	56	7.2.9.	Wheel well Cargo-Van	92
	Location of Chassis Cab Ground Terminal	57	7.2.10.	Cutting the cab roof and b-pillar roof arch	93
6.5.	Lighting	58	7.3.	Engine peripherals/drive train	95
6.5.1.	Adjusting the Headlamps	58	7.3.1.	Fuel system	95
6.5.2.	Tail lamps	58	7.3.2.	SCR system and DEF Tank location	98
6.5.3.	Marker Lamps	59	7.3.3.	Exhaust system	100
6.5.4.	Exterior lamps	59	7.3.4.	Engine cooling system	101
6.5.5.	Interior Lamps	60	7.3.5.	Engine air intake	101
6.5.6.	Rain-light sensor	60	7.3.6.	Clearance for assemblies	102
6.5.7.	Aftermarket tail light installation	60	7.3.7.	Engine speed regulation	102
6.6.	Mobile communication systems	62	7.4.	Interior	103
6.6.1.	Equipment	62	7.4.1.	General Information	103
6.6.2.	Connecting and routing the wiring for the radio antenna	62	7.4.2.	Safety equipment	104
6.6.3.	Radio	63			

7.4.3.	B-Pillar cover removal & reinstallation	109
7.4.4.	Reducing noise in the vehicle interior	110
7.4.5.	Ventilation	111
7.5.	Additional equipment	112
7.5.1.	Retrofitting an air-conditioning system	112
7.5.2.	Auxiliary heating	112
7.5.3.	Power take-offs	113
7.6.	Attachments	114
7.6.1.	Wind deflectors	114
7.6.2.	Attachment above cab	114
7.6.3.	Roof racks	114
7.6.4.	Fitted shelving/installations	115
7.6.5.	Loading cranes	118
7.6.6.	Loading tailgate (lifting platform)	119
7.6.7.	Trailer hitch	120
7.6.8.	Underride guard	121
8.	Design of bodies	122
8.1.	Mounting frame	122
8.1.1.	Material quality	122
8.1.2.	Design	122
8.1.3.	Section dimensions / dimensioning	123
8.1.4.	Attachment to the frame	124
8.1.5.	Mounting frame as floor assembly	127
8.2.	Self-supporting bodies	127
8.3.	Modifications to the interior	128
8.3.1.	Retrofitting additional rear seats	128
8.4.	Modifications to Cargo vans	128
8.5.	Platform bodies	129
8.6.	Cargo vans	129
8.7.	Refrigerated vehicles	129
8.8.	Dump bodies	129
8.9.	Rescue vehicles	130
8.10.	Torsional rigidity of body types	130
8.11.	RV Conversion	131
8.12.	Integrated Bodies	132
8.13.	Bodies on chassis with lowered roof	134
8.13.1.	Mounting the auxiliary roof frame	134
8.13.2.	Mounting the body on the auxiliary roof frame	134
9.	Calculating the center of gravity	136

Alterations

- 3.1.1. Selecting the suspension package
- 6.3.1. Auxiliary battery retrofit guidelines
- 6.3.4. Alternator
- 6.5.7. Aftermarket tail light installation
- 6.6.3. Radio
- 7.2.5. Retrofitting Windows
- 7.2.10. Cutting the cab roof and b-pillar roof arch
- 7.3.1. KL1 Auxiliary Diesel Fuel Tap (standard)
- 7.3.2. Small DEF Tank 12L KP2
- 7.4.3. B-Pillar cover removal & reinstallation
- 8.13. Bodies on chassis with lowered roof
- 8.13.1. Mounting the auxiliary roof frame
- 8.13.2. Mounting the body on the auxiliary roof frame

Revised

- 6.3.1. Retrofitting a battery isolating switch

1. Introduction

This is the Body Builders Information Book for Mercedes-Benz USA LLC (MBUSA) and Mercedes-Benz Canada (MBCAN) and Daimler Vans USA LLC (DVUSA) Mercedes-Benz SPRINTER & Freightliner SPRINTER Vans and Chassis Cabs.

This publication provides Body Builders who modify or install equipment in Mercedes-Benz Sprinters & Freightliner Sprinters (“**SPRINTER**”) Engineering specifications and assists them with their regulatory responsibilities.

The specifications and descriptions contained in this book, including regulatory information, are believed to be accurate at time of publication. Nevertheless Body Builders should consult with legal counsel to ensure compliance of pertinent laws and regulations. Periodically, this book will be updated as new products are introduced and additional information regarding these products become available.

Upon written requests MBUSA, MBCAN and DVUSA designee set forth below will provide certain additional technical data.

SPRINTER ENGINEERING USA/Canada

Contact information see page 19.

Prior to making any modifications to or installing any equipment in or on a SPRINTER, read this Information Book, and if necessary consult with SPRINTER ENGINEERING USA/Canada. Copies of this book and technical bulletins may be obtained through the following website:

www.sprinter-engineeringcompliance.com

For options and model information please visit the following Websites:

www.sprintervansusa.com

1.1. The aim of the Body Builder Information Book

The Design of the Body Builder Information Book is divided into 10 interlinked sections to help find the required information more quickly:

1. Introduction
2. General
3. Planning of bodies
4. Technical Limit in values for planning
5. Damage prevention
6. Electrics/electronics
7. Modifications to the basic vehicle
8. Design of bodies
9. Calculating the center of gravity

Further information and technical data is available in 2D drawings as separate documents in the aforementioned website.

The table of content in this PDF format is linked to help find the required information more quickly.

Ensure that the limiting values selected in Section 4 are observed as design planning must be based on these values.

The sections entitled “Modifications to the basic vehicle” and “Body Design” are the main sources of technical information contained in this Body Builder Information Book.

1.2. Vehicle Safety

Warning

Before installing bodies, attaching, mounting, installing or modifying assemblies, please read the relevant section of the detailed Operating Instructions concerning installation work. You could otherwise fail to recognize dangers, which may cause serious injury or death.

Notes on vehicle safety

We recommend that you only use parts, assemblies, conversion parts and accessories that have been recommended by MBUSA MBCAN and DVUSA for the type of vehicle concerned.

Any modifications to the vehicle that change the vehicle's certification could endanger road users, or adversely affect exhaust emissions or noise.

The use of parts, assemblies, conversion parts or accessories that have not been recommended may jeopardize the safety of the vehicle.

Ensure that you comply with all applicable regulations as retrofitted equipment on or modifications the vehicle will change the vehicle and may invalidate the vehicle's certification.

1.3. Operating Safety

Warning

Work incorrectly carried out on equipment and its software could prevent this equipment from working. Since the electronic systems are networked, this might also affect systems that have not been modified.

Malfunctions in the electronic systems could seriously jeopardize the operating safety of the vehicle.

Have work on or modifications to electronic components carried out at a qualified specialist workshop which has the necessary expertise and tools to carry out the work required.

We recommend that you use an authorized Mercedes-Benz SPRINTER or Freightliner SPRINTER Service Centers for this purpose. In particular, work relevant to safety or on safety related systems must be carried out by a qualified specialist workshop.

Some of the safety systems only function when the engine is running. For this reason, do not switch off the engine when the vehicle is in motion. Shutting the vehicle off while in motion impairs the vehicle brake system, driving stability and handling characteristics and may cause serious injury or death.

1.4. Regulatory Requirements:

The U.S and Canadian Governments have established emission standards and motor vehicle safety standards for new engines and/or new vehicles and equipment, under the provisions of the Clean Air Act, the Noise Control Act and the National Traffic and Motor Vehicle Safety Act in the U.S., and the Canadian Motor Vehicle Safety Act in Canada (“Acts”). The acts govern original equipment manufacturers of the Mercedes-Benz SPRINTER & Freightliner SPRINTER vans, dealers, Body Builders and others engaged in the manufacturing and marketing of new motor vehicles and equipment.

Specifically, Part 568 of the Title 49 Code of Federal regulations (CFR) specify detailed regulatory requirements for vehicles manufactured in two or more stages, including Final Stage Manufactures. This document is intended to fulfill a part of Daimler AG’s obligations as the original equipment manufacturer or as an incomplete vehicle manufacturer. Section Emission and Safety (→ chapter 2.1), identifies regulatory requirements to assist Intermediate and Final Stage Manufacturers, in determining their obligations to conform to these standards.

Completed SPRINTERs “As Delivered”, are certified to comply with the aforementioned applicable standards. Compliance labels affixed to SPRINTERs and engines, provide the status of initial compliance at the date of manufactured by Daimler AG (DAG).

Body Builders and Dealers who make any modifications which may affect the final certification of the engine, vehicle or equipment assume the sole responsibility for the vehicle.

Body Builders should consult with legal counsel concerning the final certification status of the vehicle.

Further it is the Body Builder’s responsibility to ensure that such modifications do not affect the safety of the vehicle. Contact the Environment Protection Agency (U.S. EPA) & the California Air Resources Board (CARB) concerning the applicable U.S. & California exhaust emissions and noise standards, and the National Highway Traffic Safety Administration (NHTSA) concerning the applicable U.S. vehicle safety standards. For Canadian

standards contact Environment Canada and Transport Canada respectively.

1. Upon completion of the modified vehicle, the Body Builder is required by law (Title 49 of the Code of Federal Regulations S567.7 in the United States, the Clean Air Act section 203(a), and under provisions of, EPA CFR Part 86 section 86.09911; Emissions standards for 1999 and later model year diesel heavy duty engines and vehicles) to certify that it continues to comply with all applicable Federal and Canada Motor Vehicle Safety standards/Regulations. In addition, the modified vehicle must continue to comply with all applicable Federal, Canada and/or California Emissions regulations. In the United States, sale of a non-complying new vehicle is illegal and is punishable by a fine of up \$25,000 (Federal) and \$5,000 (California) per vehicle for emissions non-compliance, \$1,000 per vehicle for safety non-compliance, plus a recall and other sanctions.

2. The Body Builder is responsible for certifying the altered vehicle pursuant to Title 49 of the Code of Federal Regulations S567.7 and S568.8 in the United States or to Section 9 of the Canadian Motor Vehicle safety Regulations in Canada.

3. Daimler AG makes no representations with regard to conformity of the altered vehicle to any other Federal or Canada Motor Vehicle Safety Standards or Regulations that may be affected by the vehicle alteration; it is the responsibility of the Body Builder to certify that the vehicle conforms to any other standards affected by the vehicle alteration.

1.5. Definitions

Body Builders include Final-Stage Manufactures, intermediate Manufacturers, incomplete Vehicle Manufacturers, Vehicle Alters and component suppliers.

Complete Vehicle means a vehicle that requires no further manufacturing operations to perform its intended function, other than the addition of readily attachable components, such as mirrors, tires or tire and rim assemblies, of finishing operations such as painting.

Completed SPRINTERS "As Delivered" means SPRINTERS manufactured by Daimler AG reassembled if necessary by Daimler AG's designee, certified to comply with all applicable laws and regulations and delivered as a complete vehicle (Cargo & Passenger Vans, Chassis Cab) to Dealers, Body Builders and others engaged in the manufacturing and marketing of new motor vehicles and equipment.

Daimler Group (DG) Parts means genuine parts, accessories for installation on or attached to vehicles, components, aggregates, assemblies, including those for exchange or replacement which are supplied by or through MBUSA, MBCAN & DVUSA or any of its parent companies, affiliates or subsidiaries.

Dealers mean entities authorized by MBUSA, MBCAN & DVUSA to sell and/or service SPRINTERS.

Final-Stage Manufacturer means a person who performs such manufacturing operations on an incomplete vehicle that it becomes a completed vehicle.

Incomplete Vehicle means an assembly consisting, as a minimum, of a frame and chassis structure. Power train, steering system, suspension, system and braking system, to the extent that those systems are to be part of the completed vehicle, that requires further manufacturing operations, other than the addition of readily attachable components, such as mirrors or tire and rim assemblies, or minor finishing operations such as painting, to become a Completed Vehicle.

Incomplete Vehicle Manufacturer means a person who manufactures an incomplete vehicle by assembling components none of which, taken separately, constitute an incomplete vehicle.

Vehicle Alterer is a person or company who modifies a previously certified vehicle other than by the addition, substitution or removal of readily attachable components. Readily attachable components can mean mirrors, tire and rim assemblies, or minor finishing operations such as painting.

1.6. Warranty and Vehicle Safe Operation:

Daimler AG requires the use of Genuine DG parts and DG replacement & conversion Parts, or replacement & conversion Parts and accessories expressly approved by the SPRINTER Van Manufacturer in order for Body Builders to maintain regulatory compliance of these components or equipment as well as the durable and safe operation of SPRINTERS. In areas beyond regulatory compliance, Body Builders may elect to use other parts or conversion parts or accessories and assume the Manufacturers' warranty of these parts themselves.

If these conversion parts cause damage to the original DG Parts, the warranty of these original DG Parts is void. It is the Body Builder's responsibility to ensure that non-approved replacement conversion parts & accessories do not render the vehicle unsafe.

2. General

2.1. Emissions and safety information

A complete SPRINTER Van “As Delivered” or a Chassis Cab, i.e. an incomplete vehicle, delivered by MBUSA, MBCAN & DVUSA to Dealers or Body Builders is certified for by Daimler AG for compliance with the U.S. and Canadian emissions and safety standards at the time of manufacture. If this vehicle is altered, after delivery by MBUSA, MBCAN & DVUSA, Body Builders and/or Dealers assume the regulatory responsibility for certification

This section provides general information concerning applicable emissions and safety standards at the time of the vehicle manufacture. This section is written to assist Body Builders in understanding the U.S. EPA and the CARB exhaust emission and noise standards, Federal Motor Vehicle Safety Standards (FMVSS) and Canadian Motor Vehicle Safety Standards (CMVSS). SPRINTER ENGINEERING neither approves nor recommends any modifications or additions to the SPRINTER vehicle, which may cause noncompliance with any EPA or FMVSS or CMVSS standards, or render the vehicle unsafe.

Questions concerning the content of this Section can be directed to MBUSA, MBCAN or DVUSA designee set forth below:

Michael D. Scott
Compliance Support Management
SPRINTER Engineering & Compliance
Mercedes-Benz USA
FAX: 843-695-5127

Adrian Coleman
Product Compliance Manager
Mercedes-Benz Canada, Inc.
FAX: 416-423-5027

Engine calibrations such as fuel output settings, injection timings, emission control device calibration and location, charge air and cooling system calibration and locations are prohibited from any alterations from the certified configurations.

Provisions of the Clean Air Act also prohibit any persons, including but not limited to, Dealers or Body Builders to remove or render inoperative any devices or elements of design installed in a motor vehicle engine in compliance with the regulations. Please refer to Section Exhaust System (→ chapter [7.3.2](#)) for further information.

2.1.1. Vehicle noise emission control information

The Noise Control Act of 1972 and the 40 CFR Part 205 U.S. EPA regulations, “Transportation Noise Emission Controls”, require new medium and heavy trucks over 10,000lbs. GVWR to comply with an exterior drive-by noise standard of 80 dB(A). In Canada, CMVSS 1106 Noise Emissions Standard requires an additional interior sound level certification at 90 dB(A).

All SPRINTER vehicles come equipped with extensive NVH equipment.

Body Builder should, however, consult with an attorney concerning interpretations of the applicable laws and regulations and determine if the modification Body Builder made the SPRINTER may affect the final certification of compliance of the vehicle. Further, it is the Body Builder’s responsibility to ensure modifications do not render the vehicle unsafe.

2.1.2. Exhaust emission control information

The sprinter engines, Mercedes-Benz OM642, are certified with the U.S. EPA, and the Environment Canada and CARB, to comply with the heavy-duty diesel engine exhaust emission standards under Title II, Section 206 of the Clean Air Act and 40 CFR Part 86 regulations. Proof of this EPA certification is shown by an exhaust emission control label, i.e., an “important Engine information” label, (→ chapter [2.6](#)), affixed to the rocker cover of the engine for diesel powered vehicles and VEC I label affixed to the front cross member for gasoline power vehicles.

Provisions of the EPA regulations require that the emission-related components functions in-use over the prescribed full useful life period as certified, i.e., 8 years or 110,000 miles, whichever occurs first. To be certain that these components function properly, the end users are required to use appropriate fuels and lubricants and maintain these components properly in accordance with the Operator’s Manual and Service Booklet.

In addition, applicable noise control packages, which were tested at over 100% reduction in noise levels below the aforementioned noise standards. Final Stage Manufactures should consult with their attorney concerning the compliance of their vehicles with appropriate regulations and laws, once they are altered or modified. The law and regulations prohibit tampering with noise control devices or components.

Specifically, the removal or rendering inoperative of any devices or elements of design incorporated into any new vehicle for the purpose of noise control is not permitted. Such devices or elements are identified as noise emission related components, such as engine calibrations including governor settings, exhaust system components, air induction system components, radiator, shield, fan/drive, noise shields or acoustical absorptive material, etc.

The regulations also require maintenance of the noise control performance in use, to comply with the U.S. EPA 40 CFR Part 202, or DOT 49 CFR part 325, Exterior Drive-By Noise Emission Standards for Interstate Motor Carrier.

2.2. Vehicle safety standards information

In the U.S. National Traffic and Motor Vehicle Safety Act of 1966 and NHTSA's FMVSS regulations and in Canada, Motor Safety Act of 1993 and Transport Canada's (TC) CMVSS, identify certain requirements and certification responsibilities for the various stages of vehicle manufacturing.

Therefore, Body Builders and Dealers need to review all regulatory requirements carefully to ensure compliance with applicable standards.

Please consult with an attorney to ensure compliance with applicable laws or standards.

2.2.1. FMVSS 101/CMVSS 101

This vehicle, when completed, will conform to Standard 101. Controls and Displays, provided that no alterations are made to the vehicle controls, which are installed on the vehicle and covered by the standard Alterations include location identification and/or illumination of the controls.

2.2.2. FMVSS 102/CMVSS 102

This vehicle, when completed, will conform to Standard 102, Transmission Shift Level Sequence, Starter Interlock and Transmission Braking Effect, if no alterations are made to the transmission, transmission controls, connecting linkages and cables, starting motor wiring or plumbing, neutral safety switch and ignition or equivalent switch and related wiring, or shift level position identifications.

2.2.3. FMVSS 103/CMVSS 103

This vehicle, when completed, will conform to Standard 103, Windshield Defrosting and Defogging Systems, if no alterations are made to the windshield defrosting and defogging systems, controls, wiring plumbing, vehicle heater assembly, or the airflow to the windshield.

2.2.4. FMVSS 104/CMVSS 104

This vehicle when completed will conform to Standard 104, Windshield Wiper and Washing System, if no alterations are made to the windshield wiper arms, blades, washer, control, wiring, or plumbing.

2.2.5. FMVSS 105/CMVSS 105

This vehicle, when completed, will conform to Standard 105, Hydraulic Brake System, if none of the gross axle (GAWR) or gross vehicle weight ratings (GVWR) are exceeded, and if no alterations are made to affect the braking system, hydraulic system components and fittings, the anti lock system components or electrical circuitry, tire size, or wheelbase. In addition, the center of gravity after modifications, or the combined centers of gravity of all added items by subsequent manufacturers must conform to requirements (→ chapter 9) of the Body builders Information Book on Calculation of Center of Gravity after Modifications.

2.2.6. FMVSS 106/CMVSS 106

This vehicle when completed will conform to Standard 106, Brake Hoses, if no alterations are made to the hydraulic brake hoses, brake hose assemblies, or the brake hose fittings including the labeling on these components.

2.2.7. FMVSS 108/CMVSS 108

This vehicle, when completed, will conform to Standard 108, Lamps, Reflective Devices, and Associated Equipment, if no alterations are made to lamp assemblies and/or their mountings, or Reflective devices and/or their mountings and no obstructions are installed which limit visibility of any items.

2.2.8. FMVSS 110/CMCSS 110

The completed SPRINTER as delivered starting with production date of September 2004 conforms to standard 110, tire selection and rims specially concerning (→ chapter 4.2) placard requirement, if no alterations are made to affect tire, GVWR, seating capacity and combined weight of occupants and cargo.

2.2.9. FMVSS 111/CMVSS 111

This vehicle, when completed, will conform to Standard 111, Rearview Mirrors, if no alterations are made to mirrors, mounts, locations or cab structures, or no obstructions are installed which limits the full function of these mirrors.

2.2.10. FMVSS 113/CMVSS 113

This vehicle, when completed, will conform to Standard 113, Hood Latch Systems, if no alterations are made in the hood latches, including the attachments to the hood latches.

2.2.11. FMVSS 114/CMVSS 114

This vehicle, when completed, will conform to Standard 114, Theft Protection, if no alterations are made to the steering column lock, transmission shift linkage, ignition switch interlock or the audible key-left-in warning systems.

2.2.12. FMVSS 116/CMVSS 116

This vehicle, when completed, will conform to Standard 116, Motor Vehicle Brake Fluids, if no alterations, substitutions, or introduction of foreign materials are made to the brake fluid. Use only heavy duty fluid, DOT 4+, if additional fluid is needed.

2.2.13. FMVSS 118/CMVSS 118

If so equipped, this vehicle, when completed, will conform to standard 118, Power-Operated Window, Partition, and Roof Panel Systems, if no alterations are made to the power window and related electrical systems. Additional compliance with the Standard 118 is necessary, if subsequent alterations or installations are made.

2.2.14. FMVSS 119/CMVSS 119

This vehicle, when completed, will conform to Standard 119, New Pneumatic Tires for Motor Vehicles Other Than Passenger Cars, if tires maximum load ratings are not exceeded, and no alterations or substitutions of tires, including labeling are made.

2.2.15. FMVSS 120/CMVSS 120

This vehicle, when completed, will conform to Standard 120, Tire Selection and Rims for Motor Vehicles Other Than Passenger Cars, if the GAWR or GVWR are not exceeded and no alterations or substitutions are made to tires, rims or labeling.

2.2.16. FMVSS 124/CMVSS 124

This vehicle, when completed, will conform to Standard 124, Accelerator Control Systems, if no alterations are made to any components of the throttle control or fuel metering system.

2.2.17. FMVSS 201/CMVSS 201

This vehicle, when completed, will conform to Standard 201, Occupant Protection in Interior Impact, if no alterations are made to the instrument panel, instrument panel interior compartment door, front door-mounted armrests, sun visors, seats and armrests, or other interior trims. Vehicles ordered with a D62 (Cargo Partition Provision) option, must be retrofitted with a partition wall to comply with this Safety Standard.

2.2.18. FMVSS 202/CMVSS 202

This vehicle, when completed, will conform to Standard 202, Head Restraints, if no alterations are made to the seat or heat restraint.

2.2.19. FMVSS 203/CMVSS 203

This vehicle, when completed, will conform to Standard 203, Impact protection for the driver from the steering control system, if no alterations are made to the steering control system or any of its components.

2.2.20. FMVSS 204/ CMVSS 204

This vehicle, when completed, will conform to Standard 204, Steering Control Rearward Displacement, if no alterations are made to the steering control system, including but not limited to steering wheel, steering column assembly, front structure, bumper and attaching parts, or any frontal components.

2.2.21. FMVSS 205/ CMVSS 205

This vehicle, when completed, will conform to Standard 205, Glazing Materials, if no alterations are made in the glazing material installed in the windshield, or windows of the cab, or of the passenger compartment.

2.2.22. FMVSS 206/ CMVSS 206

This vehicle, when completed, will conform to Standard 206, Door Locks and Door Retention Components, if no alterations are made to the door assembly, door latches, door hinges, door locks, door latch posts, door hinge posts, other attachments or supporting cab structure.

2.2.23. FMVSS 207/CMVSS 207

This vehicle when completed will conform to Standard 207, seating systems, if no alterations are made to the seats, seat tracks, and seat adjusters, restraining devices, release and adjustment controls, seat risers and supports, or the cab floor and supporting structure.

2.2.24. FMVSS 208/ CMVSS 208

This vehicle when completed will conform to Standard 208, Occupant Crash protection, if no alterations are made to the seat locations, seat belt assemblies, seat belt anchorages, seats, seating anchorages, cab and supporting structure, cab underbody, or if no change is made in the number of designated occupants' seating positions provided.

2.2.25. FMVSS 209/ CMVSS 209

This vehicle, when completed, will conform to Standard 209, Seat Belt Assemblies, if no alterations are made to the seat belt assemblies, seat belt anchorages and attachments, or the cab structure to which the anchorages are attached.

2.2.26. FMVSS 210/ CMVSS 210

This vehicle, when completed, will conform to Standard 210, Seat Belt Assembly Anchorages, if no additional occupant seats or seat belt assembly anchorages are installed, or if no alterations are made to the anchorages or related structure components.

2.2.27. FMVSS 212/ CMVSS 212

This vehicle, when completed, will conform to Standard 212, Windshield Mounting, if maximum unloaded vehicle weight does not exceed 7,400 lbs., or if no alterations are made to the windshield or the windshield mounting system.

2.2.28. FMVSS 214/CMVSS 214

The doors of the vehicle, when completed, will conform to Standard 214, Side Impact Protection, if no alterations are made to the doors, door frames, door latches, door hinges or mountings.

2.2.29. FMVSS 219/ CMVSS 219

This vehicle, when completed, will conform to Standard 219, Windshield Zone Intrusion, if maximum unloaded vehicle weight does not exceed 7,400 lbs., and if no alterations are made to the hood mounting system and the “protected zone” is not penetrated.

2.2.30. FMVSS 220/ CMVSS 220

This vehicle, when completed, will conform to Standard 220, School Bus Rollover Protection, if no alterations are made to the roof panel and its supporting structure. Including roof rails, front header, roof bows or roof pillars, the door window frames, the windshield or its mounting system or any window frame, subsequent to the delivery by Daimler AG.

2.2.31. FMVSS 301/ CMVSS 301

This vehicle, when completed, will conform to Standard 301, Fuel System Integrity, if the maximum unloaded vehicle weight does not exceed 7,400 lbs., or if no alterations are made to the fuel system or fuel filler pipe assembly. This Standard is not applicable to SPRINTERs rated above 10,000 lbs. GVWR.

2.2.32. FMVSS 302/CMVSS 302

This vehicle, when completed, will conform to Standard 302, Flammability of Interior Materials, if no alterations are made to any interior materials or if no conforming interior materials are added to the interior of the vehicle.

2.3. Vehicle and model designations

Vehicle and model designations

Mercedes Model	Freightliner Model	Description
M2CA144	F2CA144	SPRINTER 2500 Cargo Van 144" WB
M2CA170	F2CA170	SPRINTER 2500 Cargo Van 170" WB
M2CA170E	F2CA170E	SPRINTER 2500 Cargo Van 170" WB Ext
M3CA144	F3CA144	SPRINTER 3500 Cargo Van 144" WB
M3CA170	F3CA170	SPRINTER 3500 Cargo Van 170" WB
M3CA170E	F3CA170E	SPRINTER 3500 Cargo Van 170" WB Ext
M2CV144	F2CV144	SPRINTER 2500 Crew Van 144" WB
M2CV170	F2CV170	SPRINTER 2500 Crew Van 144" WB
M2PV144	F2PV144	SPRINTER 2500 Passenger Van 144" WB
M2PV170	F2PV170	SPRINTER 2500 Passenger Van 170" WB
M3CC144	F3CC144	SPRINTER 3500 Chassis Cab 144" WB
M3CC170	F3CC170	SPRINTER 3500 Chassis Cab 170" WB

Note:

All 3500 SPRINTERs come with Dual Rear Wheels as standard

Roof heights are sales codes

GVWR 11,030 lbs is sales code

2.4. Vehicle and model designation

2500 Cargo SPRINTER with 8550 GVWR		
<p>906.633 144" WB Low roof</p>		
<p>906.633 (D03) 144" WB High Roof</p>	<p>906.635 (D03) 170" WB High Roof</p>	<p>906.637 (D03) 170" WB ext High Roof</p>
2500 Passenger SPRINTER with 8550 GVWR		
<p>906.733 144" WB Low Roof</p>		
<p>906.733 (D03) 144" High Roof</p>	<p>906.735 (D03) 170" WB High Roof</p>	
2500 Crew Van SPRINTER with 8550 GVWR		
<p>906.633 (D03) 144" WB High Roof</p>	<p>906.635 (D03) 170" WB High Roof</p>	

3500 Cargo SPRINTER with 9990 GVWR		
<p>906.653 (D03) 144" WB High Roof</p>	<p>906.655 (D03) 170" WB High Roof</p>	<p>906.657 (D03) 170" WB ext High Roof</p>

3500 Cargo SPRINTER with 11030 GVWR		
<p>906.653 (XB5, D03) 144" WB High Roof</p>	<p>906.655 (XB5, D03) 170" WB High Roof</p>	<p>906.657 (XB5, D03) 170" WB High Roof</p>

3500 Chassis Cab SPRINTER with 11030 GVWR	
<p>906.153 144" WB Low Roof</p>	<p>906.155 170" WB Low Roof</p>

3500 Heavy Duty Cargo Van is sales code

Body code	GVWR
XB5	11030

Tonnage Rating Guide, Truck Classification

Sprinter Models	G.V.W.R.	Ton Rating	Weight Class
Sprinter 2500 Cargo	8,550 lbs	1 Ton	Light
Sprinter 2500 Passenger Van	8,550 lbs	1 Ton	Light
Sprinter 3500 Cargo	9,990 lbs	1 Ton	Light
Sprinter 3500 Cargo	11,030 lbs	1.5 Ton	Medium
Sprinter 3500 Chassis Cab	11,030 lbs	1.5 Ton	Medium

2.5. Vehicle Identification Number (VIN) Coding Summary

For Mercedes-Benz SPRINTER / Freightliner SPRINTER Vans

Manufacturer Daimler AG, Stuttgart/Germany

VIN Position	Content
1-3	World Manufacturer Identification (WMI)
4	Chassis Configuration
5-6	Model, Wheelbase, GVWR
7-8	Engines, Brakes
9	Check Digit
10	Model Year
11	Plant of Manufacture
12-17	Vehicle Serial Number

VIN Positions 1, 2, & 3:			
Code	Manufacturer	Make	Type
WDA	Daimler AG	Mercedes-Benz	Incomplete Vehicle
WD3	Daimler AG	Mercedes-Benz	Truck
WDZ	Daimler AG	Mercedes-Benz	Bus
WDP	Daimler AG	Freightliner	Incomplete Vehicle
WDY	Daimler AG	Freightliner	Truck
WCD	Daimler AG	Freightliner	Bus

Chassis Configuration - VIN Position 4:	
Code	Chassis Configuration / Intended Market
P	All 4x2 Vehicle Types / U.S.
B	All 4x2 Vehicle Types / Canada

Model, Wheelbase, GVWR - VIN Positions 5 & 6:

Code	Model	Wheelbase	Wheel Size	GVWR	
E7	C2500/P2500	3665mm	16 in.	8,000lbs to 9,000 lbs.	Class G
E8	C2500/P2500	4325mm	16 in.	8,000lbs to 9,000 lbs.	Class G
F0	C3500	3665mm	16 in.	9,000lbs to 10,000 lbs.	Class H
F1	C3500	4325mm	16 in.	9,000lbs to 10,000 lbs.	Class H
F3	C3500/3500C	3665mm	16 in.	10,000lbs to 14,000 lbs.	Class 3
F4	C3500/3500C	4325mm	16 in.	10,000lbs to 14,000 lbs.	Class 3

Engines, Brake - VIN Positions 7:

Code	Engine	Fuel	Displ./Config.	Brake
A	MP0	Diesel	3.0L/V6	Hydraulic
B	MG5+MH1 EPA 2010	Diesel	3.0L/V6	Hydraulic

Restarint Systems - VIN Positions 8:

Code	Airbag Position:
A	None
B	SA5 airbag for driver
C	SA5 + SA6 airbag for driver and co-driver
D	(SA5 + SA6 + (SH6 / SH7) + SH9) side-airbag for driver or driver and co-driver window airbags

Check Digit - VIN Position 9:

Calculated from a mathematical computation of all other VIN characters

Model Year - VIN Position 10:

Code	Model Year
A	2010
B	2011
C	2012

Plant of Manufacture - VIN Position 11:

Code	Build Location
5	Duesseldorf, Germany
9	Ludwigsfelde, Germany

Vehicle Serial Number - VIN Position 12-17:

Sequentially assigned vehicle serial number at Plant of Manufacture

2.6. Labels

The following compliance labels are affixed at the locations noted in diagrams below.

1. VIN Plate
2. Safety Certification Label
3. Exhaust Emission Control Information Label
4. Complete Vehicle Certification Label
5. Incomplete Vehicle Certification Label
6. Air Bag Warning Label
7. Tire and Loading Information Label
8. UVW Unloaded vehicle weight rating

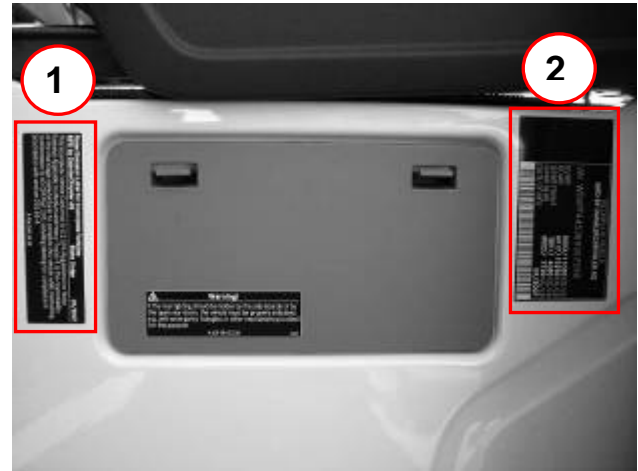

2. Safety Label location

1. Noise Emission Label
 2. Safety Certification Label
- Location: below driver seat, outward facing



1. VIN Plate

1. Vehicle Identification number
Location: left lower edge of windshield

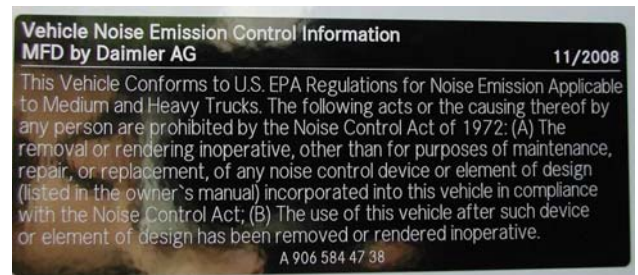

3 Noise Emission Label (example)

Location: below driver's seat, outward facing

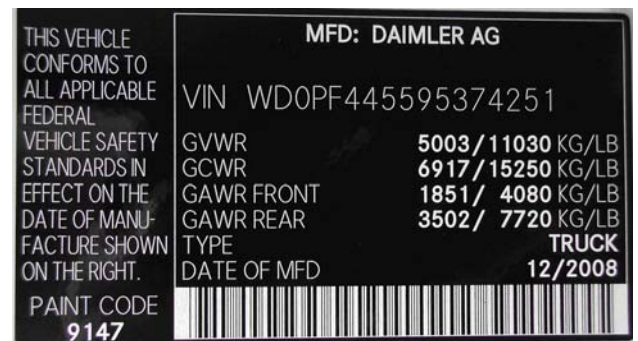

4. Complete Vehicle Safety Label (example)

Location: below driver's seat, outward facing

DAIMLER AG
VEHICLE EMISSION CONTROL INFORMATION

Conforms to regulations: **2010 MY**

U.S. EPA: **40CFR§86.1816-08 HDV** OBD: **CA II** Fuel: **Diesel**

California: **ULEV II MDV** OBD: **CA II** Fuel: **Diesel**

No adjustments needed. DID/TC/CAC/EGR/OC/DPF/SCR/NOS(2)

Group: **AMBXT03.0HD1**

EVAP:

Remarks: A 642 221 36 01 1234567

Below 10,000GVWR (radiator cowling)

DAIMLER AG
VEHICLE EMISSION CONTROL INFORMATION

Conforms to regulations: **2010 MY**

U.S. EPA: **40CFR§86.1816-08 HDV** OBD: **CA II** Fuel: **Diesel**

California: **ULEV II MDV** OBD: **CA II** Fuel: **Diesel**

No adjustments needed. DID/TC/CAC/EGR/OC/DPF/SCR/NOS(2)

Group: **AMBXT03.0HD2**

EVAP:

Remarks: A 642 221 37 01 1234567

Above 10,000GVWR (radiator cowling)

5. Exhaust Emission Control Information Label

Location: on radiator cowling



6. Airbag Warning Label

Location: on sun visor

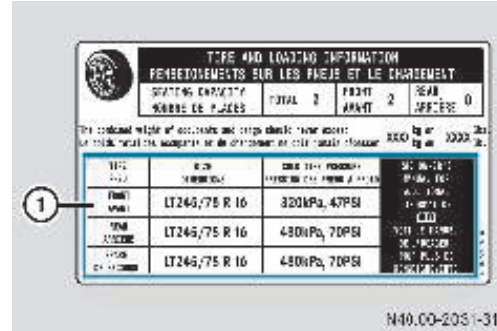

7. Tire and Loading Information (example)

Location: on driver's door frame

NOTE: Data shown on label are for illustration purposes only. Load limit data and seating data are specific to each vehicle and may vary from data shown in the illustration. Refer to label on vehicle for actual data specific to your vehicle.

For Tire and Loading Information, (→ chapter 7.1.5)

DAIMLER AG

IMPORTANT INFORMATION FOR BODY BUILDERS	INFOS IMPORTANTES POUR LES CARROSSIERS
This vehicle and engine conform to US EPA, CARB and Canada regulations applicable to 2010 model year for vehicles <u>under</u> 10,000lbs GVWR and has a maximum unloaded vehicle weight (UVW) of 7,400lbs	Le véhicule et le moteur sont conformes aux directives US EPA, CARB et du Canada applicables aux véhicules de l'année modèle 2010 avec un P.T.A.C. inférieur à 10 000lbs. Le poids à vide est de 7 400lbs.

A 906 221 66 01

Below 10,000 GVWR (radiator cowling)

DAIMLER AG

IMPORTANT INFORMATION FOR BODY BUILDERS	INFOS IMPORTANTES POUR LES CARROSSIERS
This vehicle and engine conform to US EPA, CARB and Canada regulations applicable to 2010 model year for vehicles <u>over</u> 10,000lbs GVWR and has a maximum unloaded vehicle weight (UVW) of 10,470lbs.	Le véhicule et le moteur sont conformes aux directives US EPA, CARB et du Canada applicables aux véhicules de l'année modèle 2010 avec un P.T.A.C. inférieur <u>plus de</u> 10 000lbs. Le poids à vide est de 10470lbs.

A 906 221 65 01

Above 10,000 GVWR (radiator cowling)

8. Unloaded Vehicle Weight UVW rating

2.7. Granting of body technical assistance

Modifications by Body Builders must not affect safety of the SPRINTER. MBUSA, MBCAN and DVUSA, through their designee, SPRINTER ENGINEERING will offer technical assistance concerning SPRINTER vans and Sprinter Chassis Cab, including technical data & drawings and product info brochures, but it is the responsibility of Body Builders to ensure modifications do not affect safety of the vehicle.

MBUSA, MBCAN and DVUSA, through their designee, SPRINTER ENGINEERING, neither approves nor disapproves SPRINTER modifications or equipment installations made by Body Builders, or Dealers nor others since MBUSA, MBCAN, DVUSA, and their designee, SPRINTER ENGINEERING, do not control such Body Builders, manufacturing techniques nor assume the responsibility as the final stage manufacturer and consequential product liability.

To obtain technical assistance or information, please contact MBUSA, MBCAN and DVUSA's designee:

SPRINTER ENGINEERING
8501 Palmetto Commerce Parkway
Ladson, SC 29456

Name:	Walther F. Bloch
	Manager
Dept:	SPRINTER Engineering Support
Telephone:	(843) 695-5053
E-mail:	walther.bloch@daimler.com

Name:	Andreas J. Brockmann
	Support Engineer
Dept:	SPRINTER Engineering Support
Telephone:	(843) 695-5052
E-mail:	andreas.j.brockmann@daimler.com

2.8. Body builder responsibilities

Each completed SPRINTER "As Delivered" in the U.S. is certified for the U.S. EPA or CARB exhaust emissions in accordance with 40 CFR Part 86, or Title 13 of CCR, and an exhaust emission control information label is affixed thereto. While the complete SPRINTER van "As delivered" is certified to comply with the applicable FMVSS safety regulations in accordance with 49 CFR Section 567.4 and a complete vehicle certification label is affixed thereto, the Chassis Cab is certified to comply with the applicable FMVSS safety regulations in accordance with 49 CR Section 567.5 and 568.4 and an incomplete vehicle certification label is affixed thereto.

In addition, every individual SPRINTER Chassis Cab contains an incomplete vehicle documentation information packet. SPRINTER vehicles intended for Canada are similarly certified and labeled in accordance with the Canadian regulations.

Once these SPRINTER vehicles are altered or completed with the installation of additional equipment, Body Builders assume the responsibility of final certification to all applicable emissions and safety regulations, including labeling and documentation, affected by their modifications.

→ Chapter [2.2](#) of this Book provides Body Builder with general information concerning these modifications. Provisions of 49 CFR Sections 567.5 through 567.7, and 568.8 specifically set the regulatory responsibility for the Body Builders to comply with the vehicle safety standards. Body Builders should consult with legal counsel concerning these responsibilities.

Any alterations or installations by Body Builders must comply with the following:

- Do not alter or modify SPRINTER components forward of the rear cab wall for Chassis Cab or forward of the seating reference point for SPRINTERs, unless modifications are approved component installations (such as air conditioning, radio, etc) which are manufactured, approved or endorsed by Daimler AG, MBUSA, MBCAN, DVUSA or their designee, SPRINTER ENGINEERING.
- Do not alter the location or impair functional reliability and or the clearance of all movable chassis components, i.e., axles, springs, drive shafts, steering systems, braking systems, gearshift linkages, exhaust systems, etc.
- Do not drill, alter, impair or damage the frame top and bottom flanges.
- Do not alter, damage, or relocate the SPRINTER fuel system, seat belt assemblies and anchorages, braking system and steering.
- Do not impair the operational reliability, road worthiness and drivability of the SPRINTER by body or accessory equipment installation of modification.

Body Builder is responsible for ensuring that modification or equipment installation does not affect the safety of the SPRINTER. MBUSA, MBCAN, DVUSA, and SPRINTER ENGINEERING are not responsible for any final certification or claims sounding in product liability or warranty claims, which result from any component, assembly, or system being altered, or which cause non-compliance with any of the emission control standards of motor vehicle safety standards, or which would otherwise cause the vehicle to be or become defective or unsafe.

2.9. Vehicle rollover stability information

Rollover stability is an important consideration in the safety design of a vehicle. Stability is influenced by many factors including chassis and body configuration, suspension, axle track width, tire size, tire pressure, etc. The cargo type and weight (payload), the body size, shape, and center of gravity height are particularly important. Therefore, alterations or installation of additional equipment to the SPRINTER vehicles by any Body Builder or intermediate and/or Final-Stage Manufacturer may affect rollover stability of the vehicle.

The office of Vehicle safety Research at NHTSA has conducted research and established guidelines to improve rollover stability. Body Builders are advised to consult with that Office and / or visit the NHTSA website for more information.

3. Planning of Bodies

When designing bodies in addition to a user-friendly and maintenance friendly design, the careful choice of materials and, in consequence, the associated corrosion protection measures are of great importance.

3.1. Selecting the chassis

In order to ensure safe operation of the vehicle, it is essential to choose the chassis carefully in accordance with the intended use. Planning should therefore consider the following items in particular and adapt them to the intended use:

- Wheelbase
- Engine
- Axle
- Maximum permissible gross vehicle weight (GVWR)
- Position of the center of gravity

Before carrying out any work on the body or modification work, the delivered vehicle must be reviewed to verify whether it fulfills the necessary requirements.

For more information on the chassis and body variants, see the "Model designation" section (→ chapter 2.4) or contact SPRINTER ENGINEERING.

3.1.1. Selecting the suspension package

Suspension Package I

Chassis Cab:

- Ambulance
- Armored Vehicles
- Shuttle Bus
- Box Body
- Refrigeration Vehicle

Cargo Van:

- Shuttle Bus
- Refrigeration Vehicle
- Armored Vehicles
- Tail Lift
- Mobile work shops
- RV's on cargo van

Suspension Package II

Chassis Cab:

- RV's
- Box Bodies with Tail Lift
- All vehicles with high center of gravity will benefit

Suspension Package III

Chassis Cab:

- Platform Bodies
- Stake Bodies

Cargo Van:

- Ambulance

Suspension Package IV

Chassis Cab:

- Refrigeration vehicles with built-in shelving
- Car transporter

Warning

Do not use any aftermarket suspension components not approved by DG or SEC, including but not limited to air suspension. After market suspension components may have an adverse impact on the vehicle's stability, ESP function and may lead to frame damage. The driver could lose control of the vehicle and cause an accident and may cause serious injury or death.

3.2. Vehicle modifications

Before starting work on the body, the body builder must check whether:

- the vehicle is suitable for the planned body
- the chassis model and equipment are suitable for the operating conditions intended for the body

You can plan bodies by requesting 2D drawings from SPRINTER ENGINEERING, product information and technical data or you can retrieve this information from the communications system (→ chapter 1). Furthermore, you must note the optional equipment that is fitted by the Manufacturer.

Federal laws, guidelines and registration regulations must be complied with.

Adequate clearances must be maintained in order to ensure the function and operational safety of assemblies.

Warning

Do not carry out any modifications to the steering or brake system. Any modifications may result in these systems malfunctioning and ultimately failing. The driver could then lose control of the vehicle and cause an accident and may cause serious injury or death.

Under no circumstances should modifications be made to the noise encapsulation.

3.3. Dimensions and weights

On no account should modifications be made to the vehicle width, vehicle height or vehicle length if they exceed the limiting values specified in the current version of the body builder information book for all dimension and weight specifications, please refer to the 2D drawings and technical data in the SPRINTER Body Builder Website (→chapter 1) and to the technical limiting values (→ chapter 4).

They are based on a vehicle that is fitted with standard equipment. Items of optional equipment are not taken into consideration.
Weight tolerances of up to +5% in production must be taken into consideration.

Do not exceed the gross axle weight rating (GAWR) and the gross vehicle weight rating (GVWR).
Information about GAWR & GVWR is contained in the “Technical advice on the basic vehicle” section (→ chapter 4)

Warning

Make sure that you do not exceed the permissible axle loads. Doing so would prevent the ESP system from functioning correctly. Exceeding the permissible axle loads and / or gross vehicle weights significantly impairs the vehicle driving stability and handling characteristics and may cause serious injury or death.

Information about changes in weight is available from: SPRINTER ENGINEERING (→ chapter 2.7).
All bodies must comply with the individual axle loads and the permissible gross vehicle weight.

3.4. Vehicle type identification date

The vehicle identification number (VIN) and the vehicle identification plate may neither be changed nor fitted to a different point on the vehicle. The vehicle identification number is on the lower windshield support member in the engine compartment. The type plate with the vehicle identification number and details of permissible weights is on the base of the driver's seat. Seat pedestal (→chapter [2.6](#))

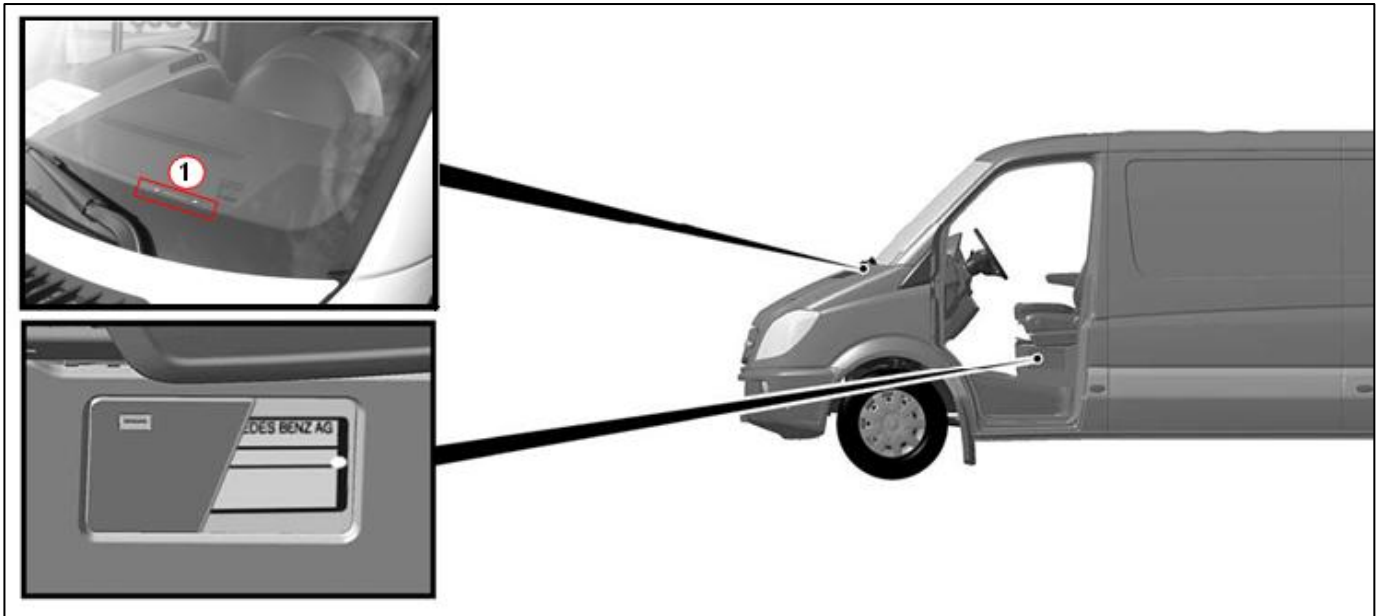

Vehicle Identification Data

1. Vehicle Identification number

Location: below driver's seat, outward facing

Vehicle stability

For approval of the vehicle with body / equipment mounted, a calculation of the height of the center of gravity of the laden vehicle must be submitted in accordance with FMVSS / CMVSS standards.

You will find the permissible heights for the center of gravity in the “Technical limiting values for planning” section (→ chapter 4). SPRINTER ENGINEERING will make no statements concerning:

- driving characteristics
- braking characteristics
- steering characteristics, and
- behavior during ESP intervention

of bodies for payloads with an unfavorable located center of gravity (e.g. rear, high and side loads) as attachments, bodies, equipment and modifications will have a considerable impact on the above characteristics. Only the body builder is in a position to make an assessment.

Warning

In extreme driving conditions, the vehicle behaves like a vehicle without ESP. The permissible axle loads, gross weights and center of gravity positions must be complied with. Exceeding the permissible axle loads and / or gross vehicle weights significantly impairs the vehicle driving stability and handling characteristics and may cause serious injury or death.

Neither in curb condition nor with equipment installed nor with modifications having been carried out may the permissible wheel, axle, or gross vehicle weights ever be exceeded.

Warning

Make sure that you do not exceed the permissible axle loads. Doing so would prevent the ESP system from functioning correctly. Exceeding the permissible axle loads and / or gross vehicle weights significantly impairs the vehicle driving stability and handling characteristics and may cause serious injury or death. Further information regarding permissible weights is contained on the vehicle type identification plates on the vehicle itself (→ chapter 4).

3.5. Tires

The body builder must ensure that:

- there is always sufficient space between the tire and the mud guard or wheel well, even if snow or anti-skid chains are fitted and the suspension is fully compressed (also allowing for axle twist) and that the relevant data in the 2D drawings from website (→ chapter 1) are observed
- only permissible tires with the correct dimension & load rating documents

Warning

Make sure that you do not exceed the permissible tire loads. Doing so would prevent the ESP system from functioning correctly. Exceeding the permissible tire loads and / or gross vehicle weights significantly impairs the vehicle driving stability and handling characteristics and may cause serious injury or death.

3.6. Bolted and welded connections

3.6.1. Bolted connections

If it is necessary to replace standards bolts with longer bolts, use only bolts:

- of the same diameter
- of the same strength grade
- of the same type
- with the same thread pitch

Warning

Do not change any bolted connections that are relevant to safety, e.g. that are required for wheel location, steering and braking functions. They may otherwise no longer function correctly. The driver could then lose control of the vehicle and cause an accident and may cause serious injury or death. Parts must be refitted in accordance with DG after sales service instructions and using suitable standard parts. We recommended the use of genuine DG SPRINTER parts.

- Federal and State regulation must be applied to all installation work.
- It is strictly prohibited to shorten the length of the free clamping bolt, change to the reduced shaft or use bolts with a shorter thread.
- No design modification is possible of bolts that are tightened to the required torque and angle by Daimler AG.
- The settling behavior of bolted connections must be observed.

Information about the SPRINTER after sales instructions is available from any authorized SPRINTER dealer.

Additional parts must be of equal or greater strength than the preceding tensioned assembly.

The use of SPRINTER Torque Values assumes coefficients of friction for the bolts in the tolerance range of (=0.08...0.14).

We recommend the use of original SPRINTER spare parts.

3.6.2. Welded connections

General

In order to maintain the high standard of welding demanded by Daimler AG, the work must only be carried out by appropriately qualified welders. The following is recommended in order to achieve high quality welds:

- clean the area to be welded thoroughly
- make several short welding beads rather than one long bead
- make symmetrical beads to limit shrinkage
- avoid more than three welds at any one point
- avoid welding in strain-hardened zones
- spot welds or step welds should be offset

The battery must be disconnected before all welding operations. Airbags, seat belts, the airbag control unit and airbag sensors must be protected from welding splashes or removed if necessary.

Parts of the floor or the roof are laser-welded. The paneling for the sidewall is laser-soldered with the roof edge paneling.

Choice of welding method

The mechanical properties of weld seams depend on selecting the adequate welding method and on the geometry of the elements to be joined. If overlapping sheets are to be welded, the choice of welding method will depend on whether only one or both sides of the work piece is/are accessible.

Accessible sides	1	Gas-shielded plug welding
	2	Resistance spot welding

Resistance spot welding

Resistance spot welding is used for welding overlapping parts which are accessible from both sides. Spot welding of more than two sheet layers must be avoided.

Distance between spot welds:

To avoid shunt effects, the specified distances between the spot welds must be maintained ($d=10e + 10\text{mm}$).

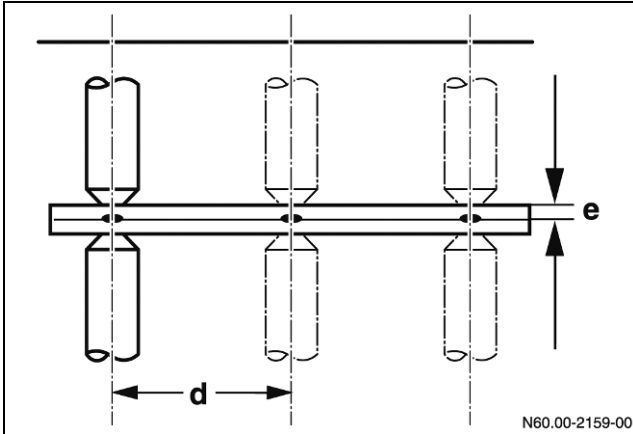

Ratio of sheet thickness to distance between spot welds

- d Distance between spot welds
- e Sheet thickness

Distance from sheet edge:

To avoid melting core damage, the specified distances to the sheet edge must be maintained ($L = 3e + 2\text{mm}$).

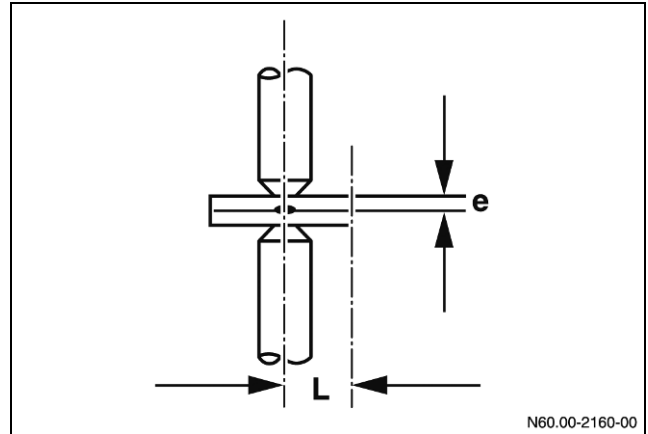

Ratio of sheet thickness to distance from the edge

- e Sheet thickness
- L Distance from sheet edge

Gas-shielded plug welding

If overlapping sheets can only be welded from one side, use either inert gas plug welding or tack welding. If the joint is produced by stamping or drilling followed by plug welding, the drilled area must be de-burred before welding.

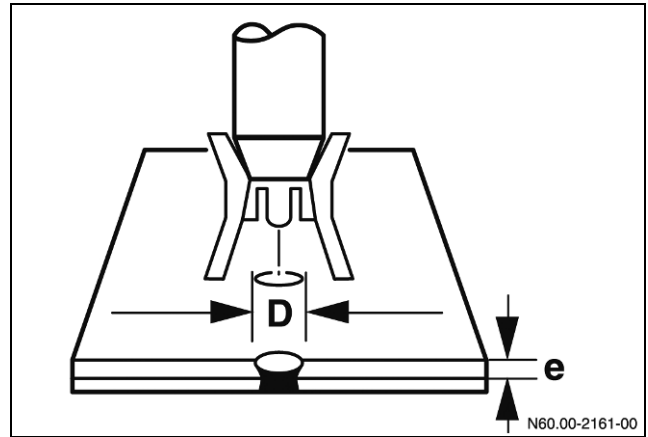

Ratio of sheet thickness to plug hole diameter

D = plug hole diameter (mm)	4.5	5	5.5	6	6.5	7
e = sheet thickness (mm)	0.6	0.7	1	1.25	1.5	2

Mechanical quality can be additionally improved by the use of slotted holes
 $(l = 2 * b)$.

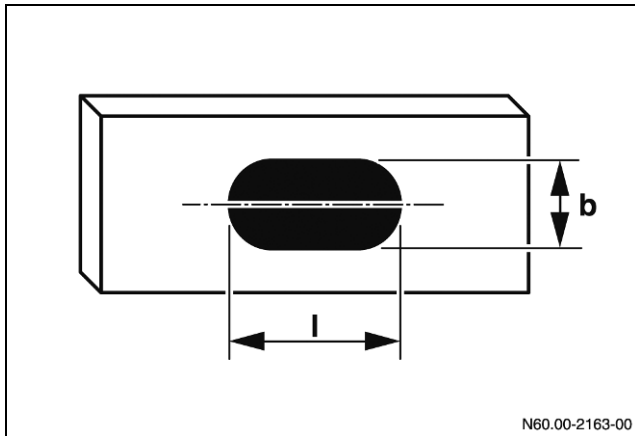

Ratio of width to length of slotted holes

- b Width of slotted hole
- l Length of slotted hole

Tack welding

If sheet thickness is $>2\text{mm}$ [$3/32$ in], overlapping sheets can also be joined by tack welding
 $(30\text{mm} < L < 40 * e; d > 2L)$
 $[1 \frac{1}{4} \text{ in} < L < 40 * e; d > 2L]$

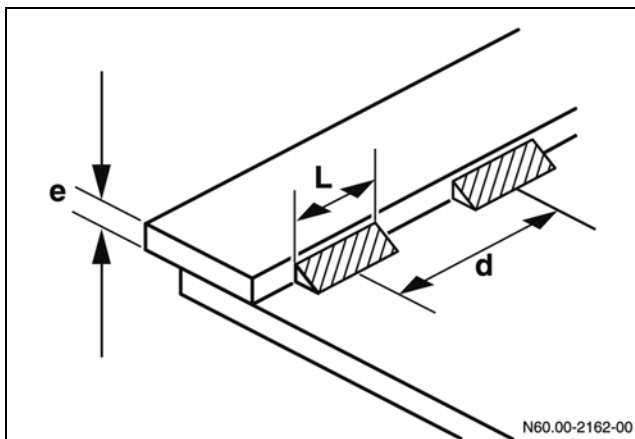

Ratio of sheet thickness to distance between spot welds

- d Distance between tack weld centers
- e Sheet thickness
- l Length of tack weld

Do not perform welding work on:

- Assemblies such as the engine, transmission, axles, etc
- Chassis, except on chassis frame extensions

More information is contained in the “Limiting values for planning” (→ chapter 4) and “Damage prevention” (→ chapter 5) sections, the “body shell” (→ chapter 7) section.

Anti-corrosion protection after welding

On completion of all welding work on the vehicle, it's important to comply with the specified corrosion protection measures (→ chapter 5.3).

When carrying out welding work, note the instructions specified “Damage prevention” (→ chapter 5) and “Modifications to the basic Vehicle” sections (→ chapter 7).

3.7. Noise Insulation

If modifications are carried out on any parts whose operations produces noise, e.g.

- engine
- exhaust system
- air intake system
- tires, etc

Sound level measurements must be made and Federal and State regulations and guidelines shall apply.

Do not remove or modify noise-insulating parts fitted to vehicle to prevent modifications from changing the vehicle's sound levels applicable to FMVSS/CMVSS regulations

Do not adversely affect the level of interior noise.

All modifications to the vehicle must comply with vehicle sound levels applicable to FMVSS/CMVSS regulations.

3.8. Maintenance and repairs

Maintenance and repair of the vehicle must not be hindered by the body, modifications or additional equipment. The Operating Instructions must be observed.

- Maintenance points and assemblies must remain easily accessible
- Stowage boxes must be fitted with maintenance flaps or removable rear panels.
- The battery compartment must be sufficiently ventilated, with provision for air to enter and exit.
- Check the condition and capacity of batteries and service them in accordance with the manufacturer's specifications (→ chapter 6.3)

Leaving the vehicle parked up for long period of time can lead to battery damage. This can be avoided by disconnecting the battery and storing it. For more information consult the owner's manual.

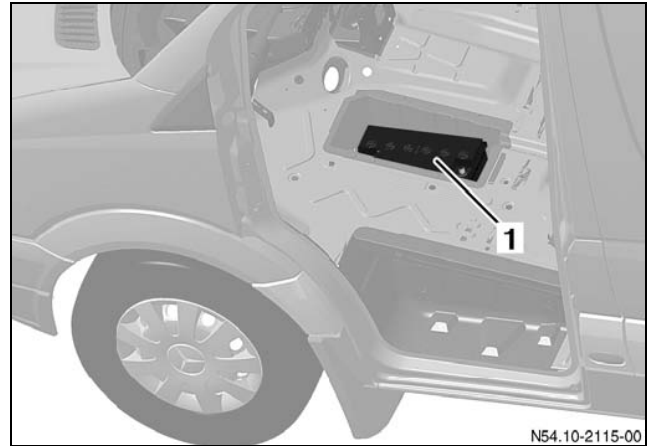

Installation location of the main battery

1. Main battery

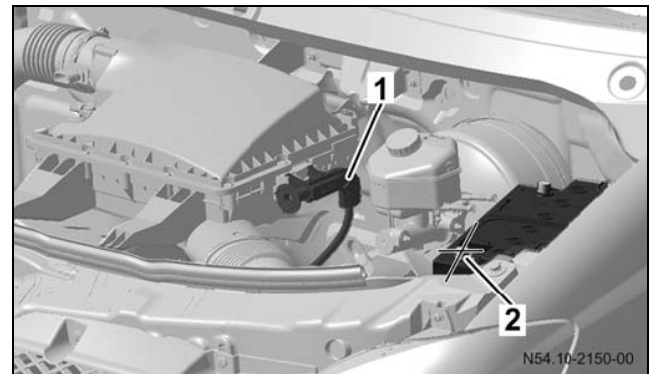

Installation location of the jump-starting / charging connection

1. Jump-starting / charging connection
2. Positive terminal, auxiliary battery – not suitable for jump-starting

The jump-starting connection for the main battery must be used if you intend to use an external power source to start or charge the vehicle's battery.

Do not use the auxiliary battery in the engine compartment for connection to an external power supply as this could result in damage to the vehicle.

Daimler AG, MBUSA LLC, MBCA and Daimler Vans USA LLC are not responsible for the cost of any additional work made necessary by the body builder which has to be performed during warranty, maintenance or repair work.

The following must be observed by the body builder before delivery of the vehicle:

- Check the headlamp setting or have this checked at an authorized Sprinter workshop.
- SPRINTER ENGINEERING recommends an authorized Mercedes-Benz SPRINTER or Freightliner SPRINTER Dealer.
- Retighten the wheel nuts to the specified torque.

The body builder must provide the vehicle with operating instructions and maintenance instructions for the body and any additional equipment installed.

3.8.1. Storing the vehicle

Storage in an enclosed space:

- Clean the entire vehicle
- Check the oil and coolant levels
- Inflate the tires to 0.5 bar / 7.25 PSI above the specified tire pressures
- Release the handbrake and chock the wheels
- Disconnect the battery and grease battery lugs and terminals

Storing the vehicle in the open (<1 month):

- Carry out the same procedure as for storing in an enclosed space
- Close all air inlets and set the heating system to "off"

Storing the vehicle in the open (>1 month):

- Carry out the same procedure as for storing in an enclosed space
- Fold the windshield wipers away from the wind shield
- Close all air inlets and set the heating system to "Off"
- Remove the battery and store it in accordance with the battery manufacturer's specifications (→ chapter 6.3.3).

Maintenance work on the stored vehicle (in storage for > 1 month)

- Check the oil level once a month
- Check the coolant once a month
- Check the tire pressures once a month

Removing the vehicle from storage

- Check the fluid levels in the vehicle
- Adjust the tire pressures to the manufacturer's specifications
- Check the battery charge and install the battery
- Clean the entire vehicle

3.8.2. Battery maintenance and storage

To avoid damage to the battery, disconnect the battery if the vehicle is to be parked for a period longer than one week. If the vehicle is parked for periods of longer than one month, remove the battery and store it in a dry place at temperatures between 32°F to 86°F [0°C to 30°C]. Store the battery in an upright position. The battery charge must be kept above 12.55V at all times. If the voltage drops below 12.55V but not below 12.1V, the battery must be recharged.

If the battery voltage drops below 12.1V, the battery is damaged and it will have to be replaced.

3.8.3. Work before delivering the modified vehicle

Checking the entire vehicle

Check the vehicle for perfect condition. Damage must be repaired where necessary.

Checking the brake system

The brake fluid must be renewed every two years. If it is not known how long a vehicle equipped with a hydraulic brake system has been in storage, the brake fluid must be renewed. Check electrical and hydraulic lines for all types of damage and replace if necessary.

Checking the battery

Check, and correct if necessary, the battery charge before delivering the vehicle.

Checking the tires

Before delivering the vehicle, check that the tires are inflated to the specified pressure and check the tires for damage. Damaged tires must be replaced.

Checking wheel alignment

We recommend that the wheel alignment be checked if modifications have been made by an authorized SPRINTER repair shop. More detailed information is contained in the SPRINTER Service Manual.

3.9. Optional Equipment

We recommend ordering available optional equipment from the factory. Information about all optional equipment available as an option is available from your authorized Mercedes-Benz SPRINTER and Freightliner SPRINTER Dealer. Optional equipment (e.g. reinforced springs, frame reinforcement, anti-roll bars, etc.) or retrofitted equipment increases the unladen weight of the vehicle. The actual vehicle weight and axle loads must be determined by weighing before mounting.

4. Technical limiting values for planning

4.1. Limiting values of the basic vehicle

This section contains the basic vehicle technical limiting values which are important for planning the vehicle's layout. In addition, you will find more information in the other sections of the current version of the Body Builder Information Book.

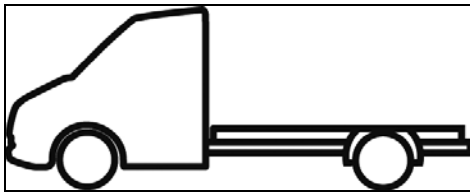

4.1.1. Maneuverability

- Under all loading conditions, the front axle load must represent at least the following proportion of the gross permissible weight:

With cargo lift	at least 30% of the gross vehicle weight
Without cargo lift	at least 25% of the gross vehicle weight

Warning

Do not exceed the maximum Center of Gravity limits. Do not exceed the maximum axle or wheel loads. Failure to adhere to the maximum Center of Gravity limits, axle loads and wheel loads, may lead to an accident with injury or death.

4.1.2. Extreme permissible positions of center of gravity

y-axis:	Never exceed the maximum side to side difference of the laden / unladen vehicle of 4%. Do not exceed the maximum permissible wheel or axle loads.
---------	--

Maximum Center of Gravity heights:

Gross vehicle weight Rating (GVWR)	Center of gravity heights, z-axis
8,550 lbs	1300 mm [51.2 in]
9,990 lbs	1300 mm [51.2 in]
11,030 lbs	1300 mm [51.2 in]

4.1.3. Center of gravity Chassis Cab

Center of gravity of a factory Chassis Cab at curb weight (CW) without options.

Chassis Cab wheelbase mm / [inch]	Center of Gravity x / y / z CG [mm]	Center of Gravity x / y / z CG [in]
3665 / [144]	1203 / 0 / 650	47.3 / 0 / 25.6
4325 / [170]	1356 / 0 / 650	53.3 / 0 / 25.6

4.1.4. Vehicle dimensions Chassis Cab

Maximum Chassis Cab vehicle width:

Mirror	Max upfit width mm / [inch]
FS2 (standard)	[96.0]

Max vehicle height:	Never exceed the maximum center of gravity (CG).
---------------------	--

Wheelbase mm / [inch]	Max. upfit length BL body length [in / ft]
3665 / [144]	155.2 / 13.0
4325 / [170]	194.1 / 16.2

4.2. Chassis limiting values

4.2.1. Permissible axle loads

Warning

Make sure that you do not exceed the permissible axle loads. Doing so would prevent the ESP system from functioning correctly on vehicles which are equipped with this feature. The driver could then lose control of the vehicle and cause an accident and may cause serious injury or death. In addition, overloading could damage the suspension system and load-bearing parts.

Information about axle loads and the maximum permissible gross vehicle weight is contained in the "Technical advice on the basic vehicle" section.

4.2.2. Approved tire sizes

Gross vehicle Weight [lbs]	Rim	Tire size	Load Index
8,550	6.5Jx16	245/75R16	120/116
9,990	5.5Jx16	215/85R16	115/112
11,030	5.5Jx16	215/85R16	115/112

4.2.3. Diameter of turning circle

Wheelbase (mm / in)	Diameter of turning circle (ft) curb to curb / wall to wall
3665 / 144	45.2 / 47.6
4325 / 170	52.5 / 54.6

4.2.4. Modifications to the Axles

No modifications whatsoever may be made to the suspension or the axles.

4.2.5. Modifications to the steering system

On no account may any modifications be made to the steering system (→ chapter [4.1.1](#))

4.2.6. Modifications to the brake system

On no account may any modifications be made to the brake system. On no account may any modifications be made to disc brake air inflow and air outflow.

4.2.7. Modifications to springs, spring mountings/shock absorbers

On no account should springs or shock absorbers be used if they do not correspond to the characteristics of standard parts or parts obtainable as optional equipment. We recommend the use of standard Mercedes Benz SPRINTER & Freightliner SPRINTER parts. On no account should modifications be made to the spring mountings (→ chapter [7.1.2](#))

4.2.8. Wheel alignment

No modifications whatsoever may be made to wheel alignment settings (→ chapter [7.1.5](#))

4.3. Body shell limiting values

4.3.1. Modifications to the body shell

Refer to the “Modifications to the basic vehicle” section (→ chapter 7).

- No modifications whatsoever may be made to the cross-member structure from the front of the vehicle back to, and including, the B-pillar.
- On no account should modifications be made to the rear door opening including the roof area
- In the event of modifications to the load-bearing structure, the total equivalent rigidity of the structure fitted by the body builder must at least equate to that of the standard vehicle.
- Clearances for fuel filler necks, fuel tank lines and fuel lines must be maintained
- It is not permissible to drill holes in or perform welding work on the A-pillar or B-pillar.
- If modifications are made to the sidewall of the panel van or the passenger van, the rigidity of the modified body must be equal to that of the basic vehicle.

4.3.2. Limiting values of the vehicle frame

If the frame is extended, the material of the extension element must have the same quality and dimensions as the standard chassis frame (→ chapter 7.2.3).

4.3.3. Vehicle overhang

The maximum vehicle overhang without exceeding the permissible axle loads and centers of gravity is:

Maximum overhang lengths	
Wheelbase l mm / [inch]	Overhang length mm / [inch]
3665 / [144]	1830 / [72.0]
4325 / [170]	2160 / [85.0]

Extensions to overhang lengths may make it necessary to reduce the maximum permissible trailer load or tongue weight. In such cases, we recommend that you consult SPRINTER ENGINEERING (→ chapter 2.7).

4.3.4. Attachment points on the frame

Attachment to the frame must be carried out as described in the “Attachment to the frame” section (→ chapter 7.2.2)

4.3.5. Vehicle roof/roof load

Maximum roof loads		
Standard roof Cargo kg [lbs]	High roof Cargo kg [lbs]	Chassis Cab kg [lbs]
300 [660]	150 [330]	100 [220]

Do not modify or remove roof bows structural parts

Wheelbase mm / [inch]	Quantity required
3665 / [144]	> 5 roof arches
4325 / [170]	> 6 roof arches

Roof arches	Position
1	to the rear of the front doors (B-pillar)
2	at the center of the load compartment sliding door (between the B- and C- pillars)
3	in the center of the vehicle behind the load compartment sliding door (C-pillar)
4-6	between the C-pillar and the rear end of the vehicle (rear pillar)

Roof height (mm)	Moment of inertia 1 per roof arch (mm)
< 250	> 40 000
< 400	> 65 000
< 550	> 86 000

4.4. Modifications of engine peripherals / drive train

4.4.1. Fuel system

Do not modify fuel system (→ chapter [7.3.1](#))

4.4.2. Modifications to the engine/drive train components

- Do not modify the engine air intake
- Do not modify the drive shaft
- Do not retrofit any engine speed regulation equipment, other than OEM equipment.
- Do not modify the exhaust system, exhaust gas after treatment components (diesel particle filter, catalytic converter, Lambda probe, etc)

4.4.3. Engine cooling system

Do not modify the cooling system including but not limited to radiator, radiator grille, air ducts, etc. (→ chapter [7.3.3](#))

The complete cross-section of the cooling air intake surfaces must remain unobstructed. This means:

- at least 11 dm² [170 in²] for the front grille (radiator and condenser)
- at least 7dm² [109 in²] for the opening in the bumper (charge-air cooler flow)

4.5. Modification to the interior

4.5.1. Modifications to airbags and belt tensions

Warning

Do not modify the airbag system or the belt tension system. Modification to or work incorrectly carried out on a restraint system (seat belt and seat belt anchorages, belt pretensioner or airbag) or its wiring could cause the restraint systems to malfunction. This means, for example, that airbags or belt tensions may be activated inadvertently or may fail in the event of an accident even though the rate of deceleration exceeds the deployment threshold and may cause serious injury or death.

- Do not modify the airbag components or the vicinity of airbag components and sensors.
- Do not modify the roof trim or its attachment if the vehicle is equipped with window bags.
- Stay clear of the airbag deployment areas (→ chapter [7.4.2](#))
- Do not modify areas around the airbag control unit

More information is contained in the “Modifications to the basic vehicle” section (→ chapter [7](#)).

4.5.2. Modifications to seats

Warning

It is not permitted to modify the seats or mount seats on the wheel wells. In the event of an accident, the seats could become detached from their anchorages and may cause serious injury or death.

More information is contained in the “Modifications to the basic vehicle” (→ chapter [7](#)) and “Modifications to the interior” sections (→ chapter [8.3](#)).

Any retrofitted rear bench seat with two- or three-point seat belts must comply with the FMVSS/CMVSS requirements.

4.6. Limits to Electrics / Electronics

Refer to the “Electrics / Electronics” section
(→ chapter 6)

4.6.1. Vehicle Marker and Clearance lamps

Vehicle marker and clearance lamps are required by law on all vehicles with total width of 80 inch and above according to FMVSS/CMVSS standards.

4.6.2. Retrofitting electrical equipment

All equipment fitted must meet FMVSS standards.

Comfort may be impaired in individual cases.

4.6.3. Mobile communication systems

Do not exceed the maximum transmission output

Waveband	Maximum transmission output (W)
Short wave < 50 MHz	100
4 m band	20
2 m band	50
Trunked radio / Tetra	35
70 cm band	35
GSM	10
3G	10

4.6.4. CAN bus

Do not modify the CAN bus or the components connected to it. The programmable special module (Code ED5) can be used to access individual types of data available on the CAN bus.

4.6.5. Electronic Stability Program

Do not modify the location, position and mounting of the ESP yaw rate sensor.

Do not modify the wiring or ESP components.

Do not modify the wheel base.

4.7. Design Limits for additional equipment

If auxiliary equipment (e.g. additional air-conditioning compressors, pumps, etc) is retrofitted, the following must be observed:

- The operation of vehicle components must not be adversely affected
- The clearance to moving vehicle parts must be guaranteed in all driving situations.
- Please refer to option code N62 and N63.

4.8. Design Limits for attachments

The maximum load capacity of a lifting platform is 500kg [1100 lbs] on a Cargo Van model and 750kg [1650 lbs] on a Chassis Cab. Mounting in accordance with the “lifting platform” section (→ chapter 7.6.6) is imperative.

4.9. Design Limits for the body

Refer to the “Design of bodies” section.

4.9.1. Design Limits of the mounting frame

Required moment of resistance of mounting frame:

Up to maximum standard wheelbase	30 cm ³
----------------------------------	--------------------

¹ Each individual mounting frame longitudinal member must have the moment of resistance specified.

For further information about mounting frames for dump bodies see (→ chapter [8.1](#))

Material quality of specified frame made of steel

Material	Tensile Strength (N/mm ²) Yield Strength (N/mm ²)
H240LA (DIN EN 10268-1.0480)	350-45 260-340
S235JRG2 (DIN EN 10025-1.0038)	340-510 >235

5. Damage prevention

Any work carried out on the vehicle must comply with accident prevention regulations

Comply with all FMVSS/CMVSS regulations and laws.

5.1. Brake hoses / cables and lines

Cover plastic lines and brake hoses before carrying out any welding, drilling and grinding work or before working with cutting discs. If necessary, the plastic lines and brake hoses should be removed.

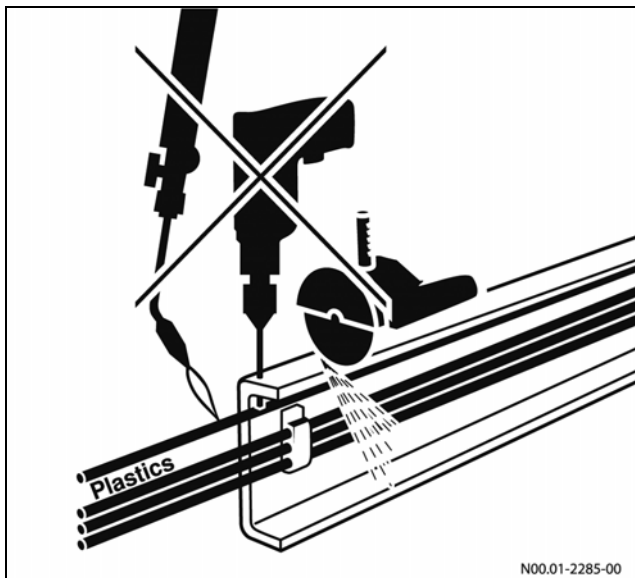

Test each of the systems for pressure loss and leaks after installing compressed-air lines and hydraulic lines. No other lines may be attached to brake hoses. Lines must be protected from heat by means of insulation.

Warning

Work carried out incorrectly on the brake hoses or cables may impair their function. This may lead to the failure of components or parts relevant to safety and may cause serious injury or death.

5.2. Welding Work

Warning

Welding work that is not performed correctly could lead to failure of components relevant to safety. It would then not be possible to rule out the risk of an accident and may cause serious injury or death.

For this reason, the following safety precautions must always be observed during any work involving welding.

- Welding work on the frame may only be carried out by trained personnel and with prior approval of SPRINTER ENGINEERING.
- Do not weld on assemblies such as the engine, transmission, axles, etc.
- Disconnect the positive and negative terminals from the battery and cover them.
- Connect the welding-unit ground terminal directly to the part being welded. Do not connect the ground clamp to assemblies such as the engine, transmission or axles.
- Do not touch electronic component housings (e.g control modules) and electric lines with the welding electrode or the ground contact clamp of the welding unit.
- Before welding operations in the vicinity of the seat belts, airbag sensors or the airbag control unit, these components must be removed for the durations of the work. You will find important information about handling, transporting and storing airbag units in the "Interior" (→ chapter 7.4)
- Before welding, cover springs and air bellows to protect them from welding spatter. Do not touch springs with welding electrodes or welding tongs.
- Cover the fuel tank and fuel system (lines, etc) before carrying out welding work.
- Use only completely dry lime basic jacket electrodes (2.5 mm diameter).
- The maximum current maybe 40 A per mm of electrode diameter.
- Weld only with electrodes connected to the positive pole of a direct current source. Always weld from bottom to top.

- MIG welding is permissible
- Only use welding wires with a thickness of between 1 and 1.2mm.
- The yield point and tensile strength of the welding material must be at least equal to that of the material to be welded.
- Plug welding is only permissible in the vertical webs of the longitudinal frame member.
- Avoid welds in bends
- There must be at least 15 mm [0.6 inch] between the weld and the outer edges.

You will find further information about welding operations in the “Planning of bodies” section (→ chapter 3), “Modifications to the basic vehicle” section (→ chapter 7) and the “Body shell” section (→ chapter 7.2). More information can be found in the SPRINTER Repair Manual.

Warning

Welding in the vicinity of the restraint systems (airbag and belts) can cause these systems to no longer function correctly. Welding is therefore not permitted in the vicinity of the restraint systems. Welding near restraint system components may cause serious injury or death.

5.3. Corrosion protection

Surface and anti-corrosion protection measures must be carried out on the areas affected after modifications and installation work have been performed on the vehicle.

Only protective agents tested and approved by SPRINTER ENGINEERING may be used for anti-corrosion protection measures performed.

Planning Measures

Anti-corrosion protection measures should be included in the planning and design stages by selecting suitable materials and designing components accordingly.

A conductive connection occurs if two different metals are brought into contact with each other through an electrolyte (e.g. air humidity). This causes electrochemical corrosion and the less noble of the two metals is damaged. The further apart the two metals are in the electrochemical potential series, the more intense electrochemical corrosion becomes.

For this reason, electrochemical corrosion must be prevented by insulation or by treating the components accordingly or it can be minimized by selecting suitable materials.

Preventing contact corrosion by means of electrical insulation

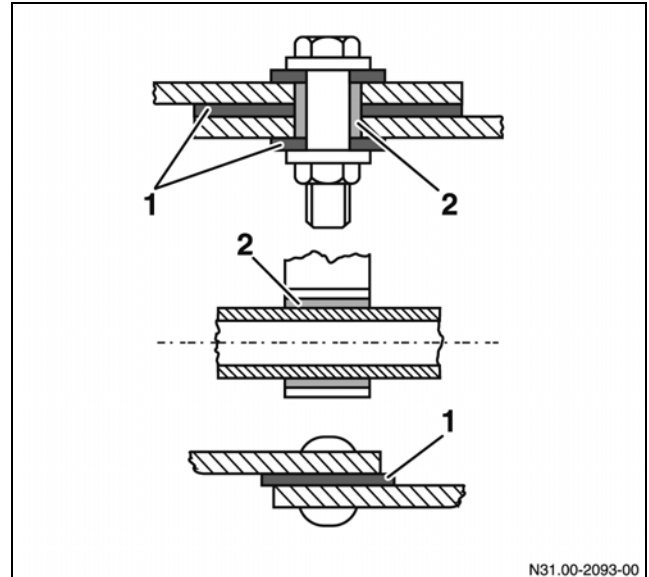

Preventing contact corrosion

1. Insulating washer
2. Insulating sleeve

Contact corrosion can be prevented by using electrical insulation such as washers, sleeves or bushings.

Avoid welding work on inaccessible cavities.

Component design measures

Corrosion can be prevented by design measures, in particular the design of joints between different materials by using the same kind of materials. There is a risk of dirt or humidity accumulating in corners, edges, beads and folds. Design measures for counteracting corrosion can be implemented using inclined surfaces and drains, and by avoiding gaps in the joints between components.

Gaps inherent in the design of welded connections and how to avoid them

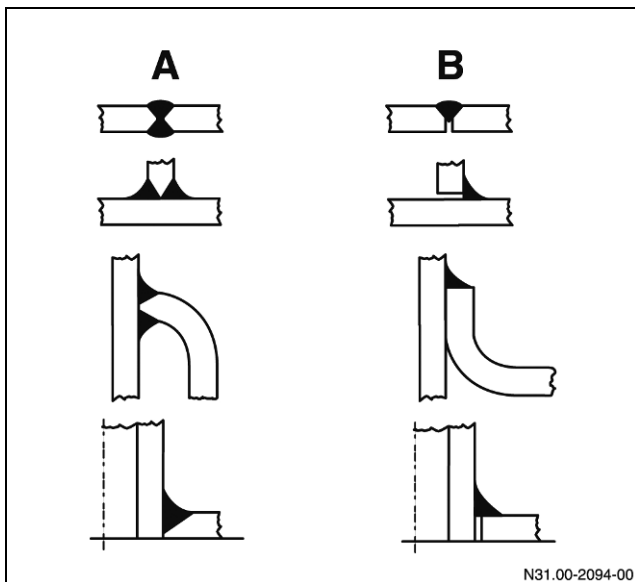

Examples of types of welded connections

A = correct
(through-welded)

B = incorrect
(gap)

Coating Measures

The vehicle can be protected by applying protective coatings (e.g. galvanization, painting or zinc coating applied by flame).

After all work on the vehicle is completed:

- Remove drilling chips
- Deburr sharp edges
- Remove any burned paintwork and thoroughly prepare surfaces for painting
- Prime and paint all unprotected parts
- Preserve cavities with wax preservative
- Carry out corrosion protection measures on the underbody and frame parts

5.4. Painting work

Paintwork damaged by the body builder must be repaired by the body builder.

Observe the following points:

- Daimler AG quality standards for initial painting and paintwork repairs must be adhered to
- Only painting materials tested and approved by Daimler AG paint may be used for any paintwork which may be necessary
- The body builder must observe the coat thickness for each individual coat as specified by the factory.
- Paint compatibility must be guaranteed when repainting

You can obtain information on the paint materials and coat thicknesses used at the factory and Mercedes-Benz SPRINTER & Freightliner SPRINTER paint numbers from any Mercedes-Benz SPRINTER & Freightliner SPRINTER Service Center.

Mask the following areas before painting:

- Sealing surfaces
- Windows
- Contact areas between wheels and wheel hubs
- Contact areas for wheel nuts
- Vents on transmission, axles, etc.
- Disc brakes
- Door Locks
- Door retainers in the rear door hinges
- Contact surfaces on the guide rails for the sliding doors
- Door retainers and opening limiters in the center guide rails
- Moving parts of the sliding door carriage
- Airbags and seat belts
- Parktronic sensors (→ chapter [6.13](#))

To dry the paint, a temperature of 80°C [176°F] must not be exceeded because high temperatures can cause damage to the control units and other components.

5.5. Towing

Warning:

Before towing, please make sure that you read the "Towing" section in the detailed Owner's Manual. You could otherwise fail to recognize dangers, which may cause serious injury or death.

Failure to observe the instructions in the Owner's Manual can result in damage to the vehicle.

5.6. Storing and delivery of the vehicle

Storing

To prevent any damage while vehicles are in storage, we recommend that they be serviced and stored in accordance with the manufacturer's specifications (→ chapter [3.8](#))

Delivery

To prevent damage to the vehicle or to repair any existing damage, we recommend that the vehicle be subjected to a full function check and a complete visual inspection before it is delivered.

6. Electrics/Electronics

6.1. General Information

Warning

Work incorrectly carried out on equipment and its software could prevent this equipment from working correctly. Since the electronic systems are networked, this might also affect systems that have not been modified.

Malfunctions in the electronic systems could seriously jeopardize the operating safety of the vehicle.

Service or modifications at electronic components must be carried out by a qualified special workshop having the necessary specialist knowledge and tools to carry out the work required.

We recommend that you use an authorized Mercedes-Benz SPRINTER or Freightliner SPRINTER Service Center for this purpose. In particular, work on systems relevant to safety must be carried out at a qualified specialist workshop. Some of the safety systems only function when the engine is running. For this reason, do not switch off the engine when the vehicle is in motion because it may cause an accident with serious injury or death.

A positive total charge balance must be ensured when additional electrical components are installed.

Do not release or remove the battery terminals when the engine is running.

Rapid-charge batteries only after disconnecting them from the vehicle's system. Both the positive and negative terminals must be disconnected.

- Electrical and electronic components must fulfill the test requirements of ISO 16750.
- Observe the directives in (→ chapter [6.3](#)) when installing additional batteries.
- Cables routed in the vicinity of exhaust systems must be insulated against high temperatures (→ chapter [7.3.2](#)).
- Cables must be routed in such a way that there are no chafing points.
- The batteries must be disconnected if the vehicle is not in use for extended periods (more than 20 days). The batteries must have sufficient charge when the vehicle is put into operation again (→ chapter [6.3](#)).
- Observe the Owner's Manual

You can obtain more information from SPRINTER ENGINEERING (→chapter [2.7](#)).

6.2. Electromagnetic compatibility (EMC)

Electromagnetic compatibility describes the ability of an electrical system to act neutrally in the vicinity of other systems when operating at full function. It does not interfere with any of the active systems in the vicinity, nor does it suffer any interference.

Electromagnetic Interference EMI occurs in the vehicle electrical circuits because of the various incompatible components. At Daimler AG, electronic components installed at the factory are checked for their electromagnetic compatibility in the vehicle. If subsequent modifications are made, this may cause discomfort in some cases. (e.g. radio noise).

When retrofitting electric or electronic systems, they must be tested for electromagnetic compatibility and this must be documented. The equipment must possess type approval.

The following standards provide information on this:

- CISPR 12
- CISPR 25
- ISO 7637
- ISO 10605
- ISO 11451
- ISO 11452
- MBN10284
- EC Directive 72/245/EEC
- ECE-R 10

6.3. Battery

The main battery is located in the floor on the left-hand side, in front of the driver's seat.

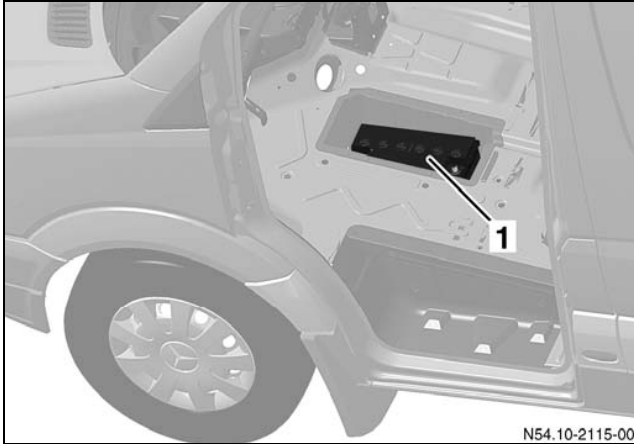

Location of the main battery

A 25 AMP current draw requires the use of the reinforced battery (Option E28). An auxiliary battery must be used for more than 25 AMP current draw.

6.3.1. Auxiliary battery retrofit guidelines

When installing electrical aftermarket equipment with a current draw of more than 25A in Mercedes-Benz Sprinters & Freightliner Sprinters it is necessary to use the optional aux battery 12V/100Ah (CODE E28).

For cost and practical reason we recommend ordering this option directly from the plant.

Note:

This guideline is not intended as a complete work instruction but as an aid for body builders and upfitters that need to retrofit Mercedes-Benz / Freightliner Sprinters with an aux battery.

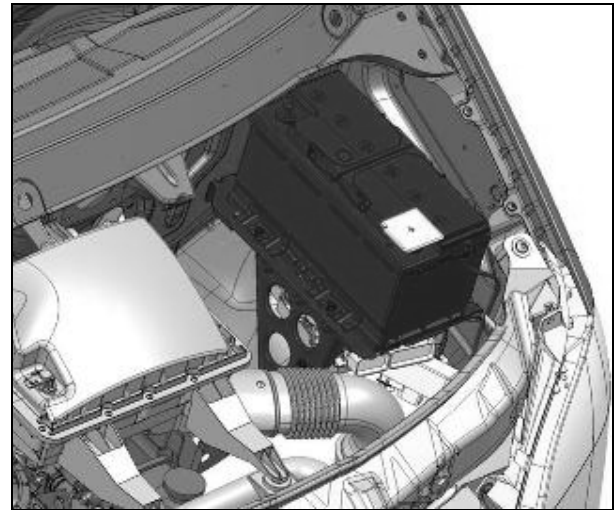

Auxiliary battery location

Work Flow Chart:

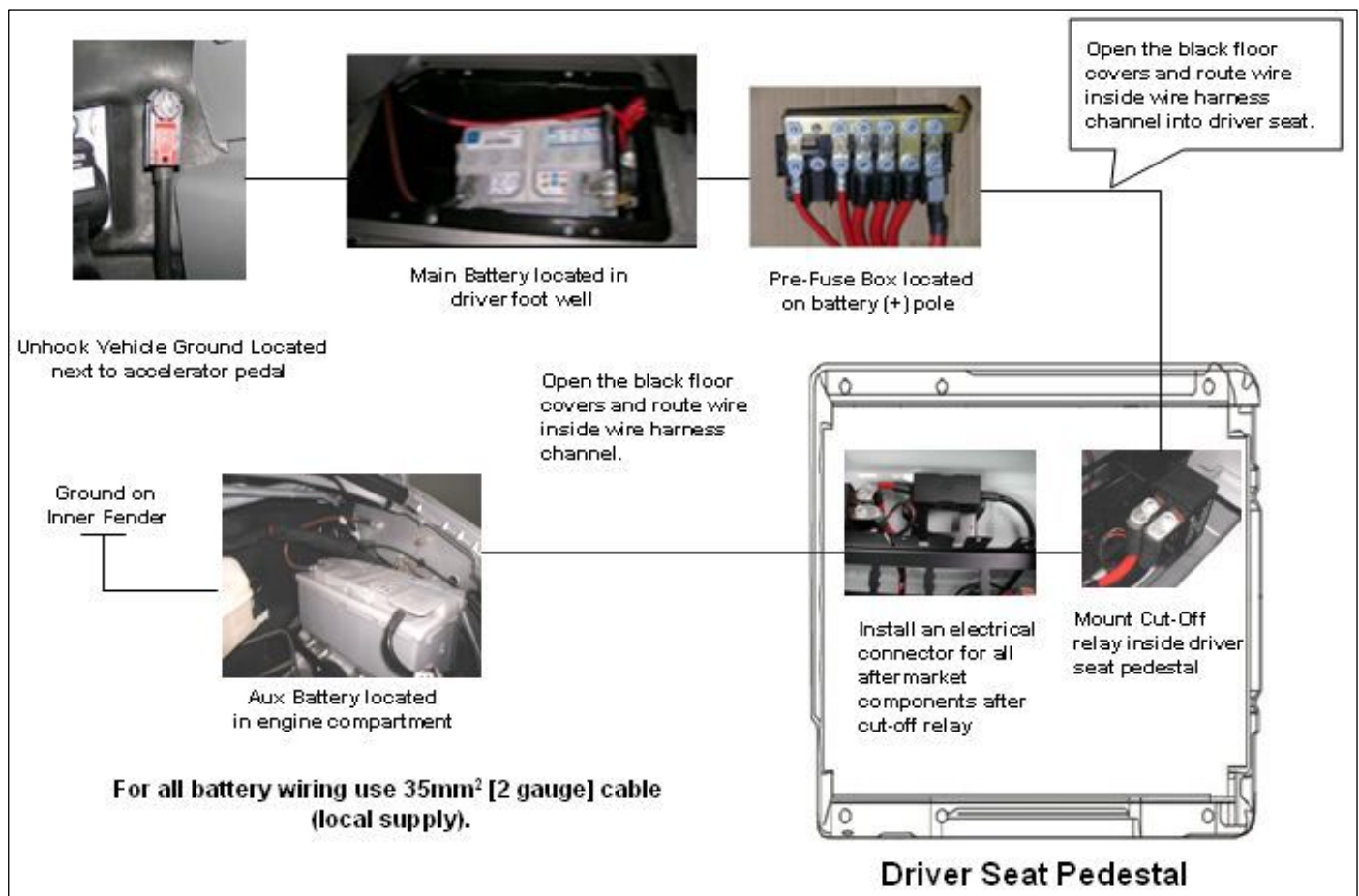

Disconnect main battery

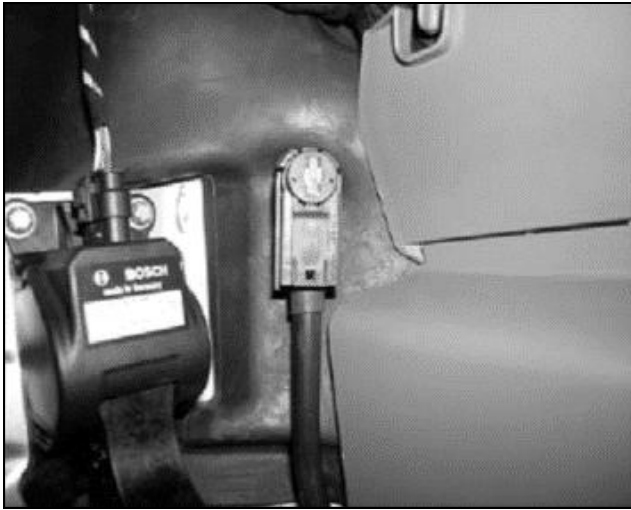

Main Battery Connector (Next To Accelerator Pedal)

Warning

Before working on the electrical system disconnect the main battery using the quick connect located right to the accelerator pedal in the driver foot well. Failure to disconnect the battery may cause serious damage to the electrical system and its components. Do not disconnect the battery before ensuring that the vehicle ignition key is in position 0 (off) or the key is removed, otherwise serious damage to the electrical system and its components may occur.

VERY IMPORTANT:

Do not install an auxiliary battery without a battery cut-off relay and suitable fuses for the charge current.

Prefuse box at main battery

Warning

Do not use aux battery as a start aid. Using an auxiliary battery as a start aid may lead to severe damage to electrical components.



Starter Battery (under driver floor)

Locate starter battery under driver floor matt. Disconnect all electrical seat connectors. Remove driver seat (4 screws).



From Main Battery

Unhook prefuse box and use existing empty terminal Position #4. See owners manual for fuse locations. Use OEM 150A fuse (MB# N 000000 000432).

For all battery wiring use 35mm² [2 gauge] cable (local supply).

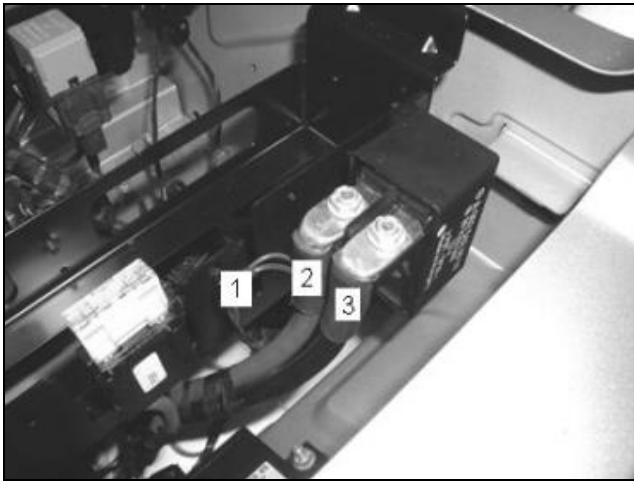
Battery cut-off relay mounting inside seat pedestal

Cut-off relay inside seat base

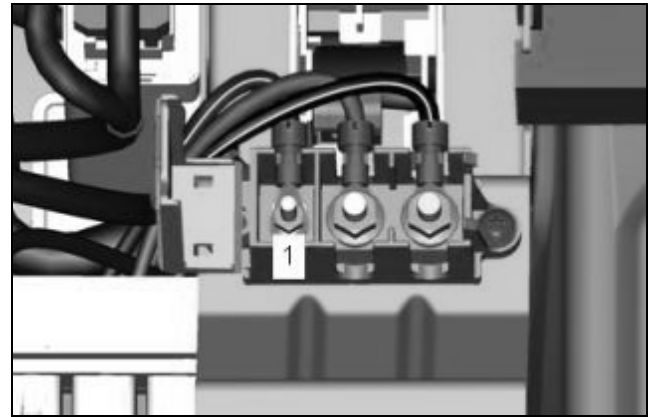
1. To Terminal 1
 2. From prefuse box (red)
 3. To aux battery (black)
- Mount a battery cut-off relay (MB#: A 002 542 40 19 or equivalent) inside driver seat pedestal
 - Route a red cable from cut-off relay to prefuse terminal using provided wire harness channel
 - Route a black cable from cut-off relay to aux battery through provided opening in firewall. (Stay clear of steering column and use convoluted tubing or equivalent)
 - Connect circuits switching wire to the EK1 Terminal 1 and use only existing ground terminals on driver seat base floor (1) (power with engine running)

EK1 terminal (under driver seat)

1. X145/1 Terminal 1 (D+)
 - Power with engine running
 - Wire color: blue/yellow
 - 12V / 10A (120W)

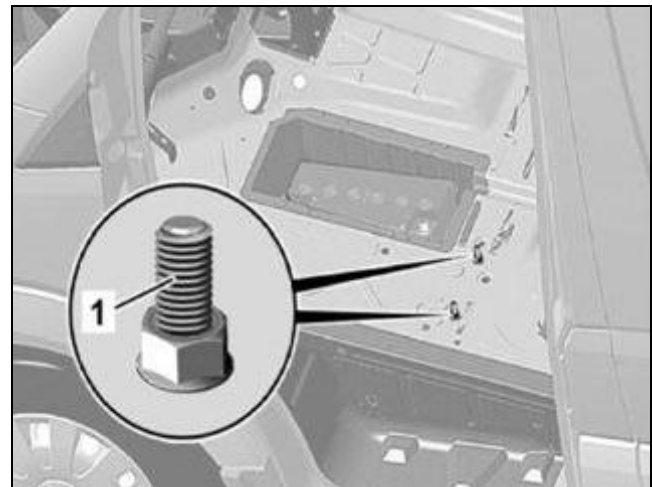
For more information see Chapter 6.4.7.

Ground Terminal

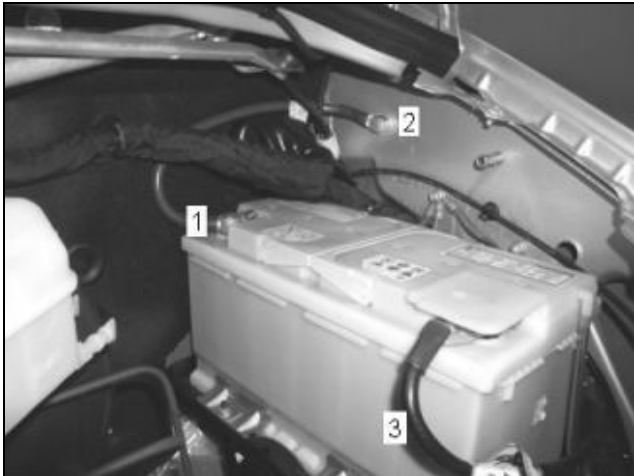
Only recommended aux battery location

Location for auxiliary battery

1. Ground (-) Battery
2. Ground to inner fender
3. Black wire from cut-off relay (+)

For all battery wiring use 35mm² [2 gauge] cable (local supply).

Warning

Only install aux battery under hood on driver side.

- Use battery support bracket (MB# A 906 540 00 23)
- Aux Battery 12V / 100Ah (MB# A 906 982 00 08)
- Connect battery ground cable (-) only to provided ground terminal inside inner fender
- Connect black wire coming from cut-off relay to the auxiliary battery terminal (+).

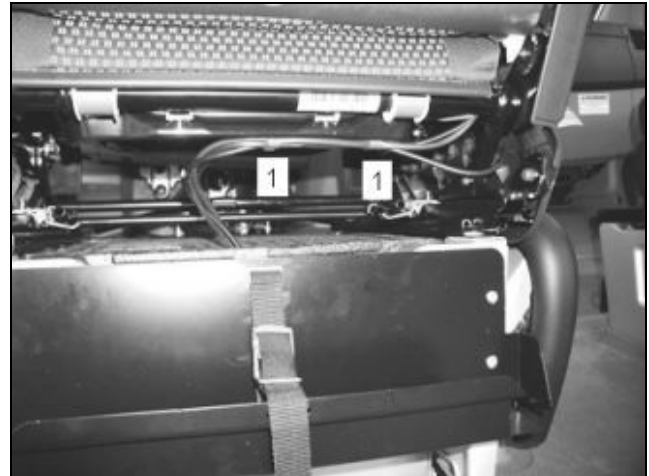
Seat reinstallation

Rear view of driver seat and pedestal

1. Reattach wire harness with provided clips located on the seat.

Attach driver seat to pedestal (4 screws) and torque with 37Nm [27.3 ft-lbs].

Slide the seat all the way forward and carefully reassemble foam seat riser cover. Hole has to be in the back.

Reconnect all seat connectors:

- Seat belt warning
- Heated seat (optional equipment)
- Seat airbag (optional equipment)

Reconnect main battery

6.3.2. Retrofitting an additional battery

Do not connect Batteries with a capacity over 100 Ah directly to the vehicle's electrical system due to potential damage to the basic vehicle.

We recommend the use of lead-antimony batteries fitted in the location provided in the engine compartment.

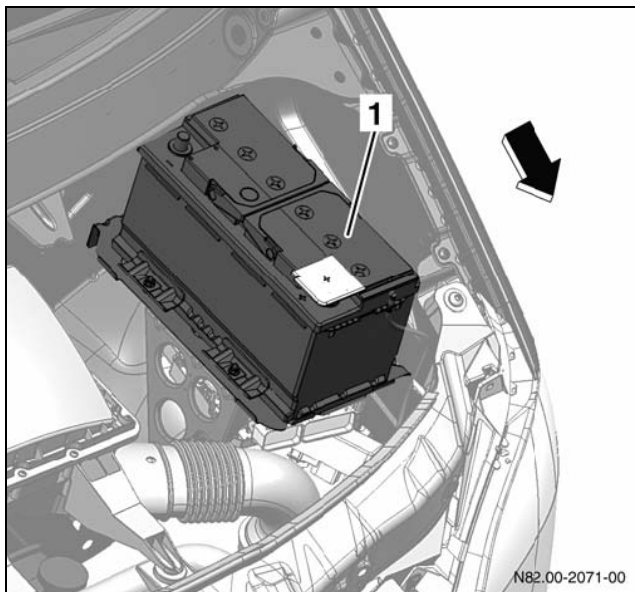

Location of the auxiliary battery

1 Auxiliary battery
Arrow Front of vehicle

If the auxiliary battery is located in the passenger compartment, battery gases must be vented to the outside via a central vent hose.

The auxiliary battery must only be fitted in conjunction with a cut-off relay and fuses suitable for the charge current.

The auxiliary battery may only be used to power auxiliary components such as the auxiliary heating, loading aids or electrical equipment in motor caravans (fridge, etc.).

If the vehicle is already equipped with an auxiliary battery, it not permitted to connect any more auxiliary batteries in parallel.

6.3.3. Battery maintenance and storage

Batteries must be checked regularly for voltage loss (self- discharge) even when removed. Only the electrolyte level check is not required with low-maintenance batteries.

You will find information on battery maintenance and storage in the "Planning of bodies" section (→ chapter 3).

6.3.4. Alternator

220 Amp

Values are estimates and can differ slightly from manufacturer.

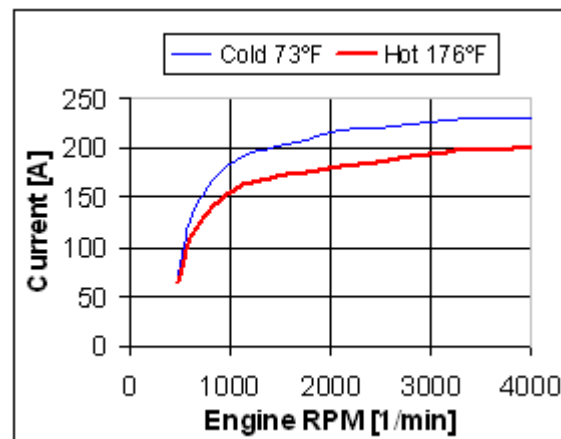

Engine RPM (1/min)	Current Cold 73°F (A)	Current Hot 176°F (A)
650	137	116
700	149	125
800	162	137
900	175	148
1000	183	154
1200	194	165
1400	201	169
1500	203	171
1600	205	173
1800	210	177
2000	215	180
2500	222	188
3000	226	193
3500	230	198
4000	231	199

Note:

A new generation of regulators is used in the Sprinter. The alternator regulator is equipped with a LIN (Local Interface Network) interface. The characteristics of the LIN alternators are fixed in the engine control unit – for this reason **aftermarket alternators can not be retrofitted**. The only available alternator for the Sprinter starting model year 2010 is 220 Amp alternator (standard equipment).

No D+ (engine running positive signal) output is available at alternator with LIN Bus technology, only at the body builder connector EK1 (see Chapter 6.3.1.) under driver seat.

F57 (300A) Alternator Fusing

- The alternator wiring harness is fused with a 300A. The fuse is integrated in the wiring harness
- The fuse location is at the rear of the engine at bell house

In case a short occurs and the fuse blows, then the alternator wiring harness has to be completely replaced!

6.4. Interfaces

6.4.1. CAN bus and networking

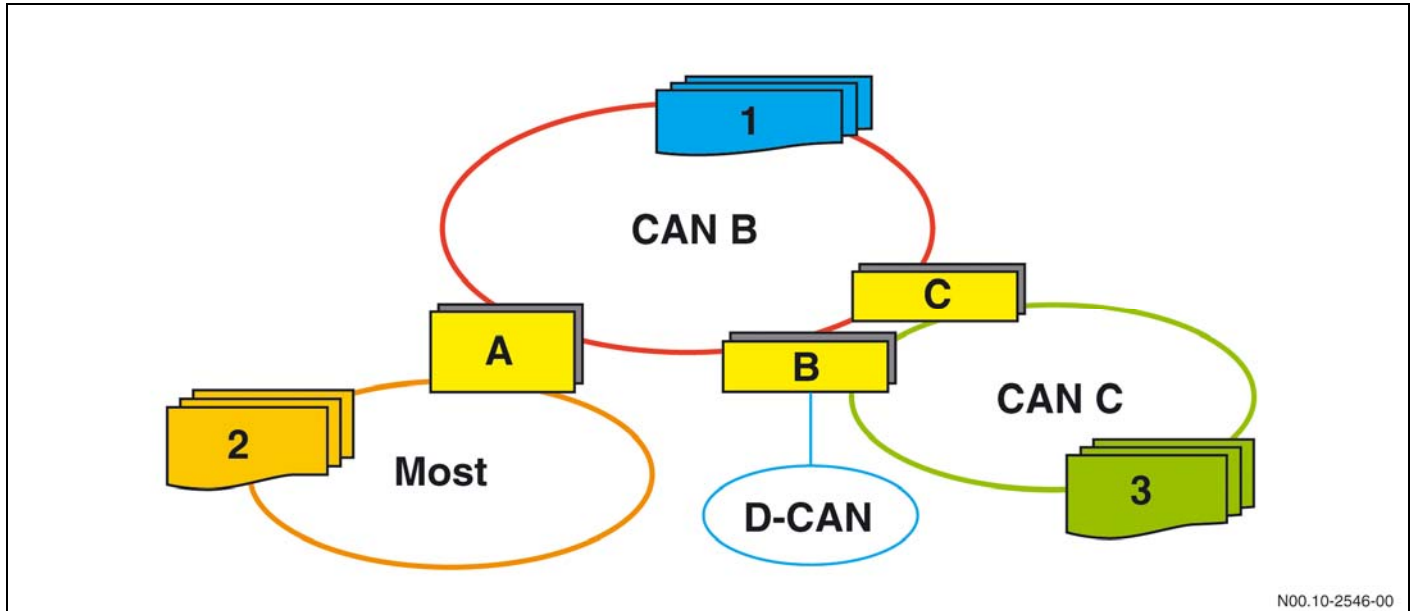

N00.10-2546-00

1	2	3
I-CAN = interior CAN (CAN B, 83.333 kBit/s)	MST = optical bus	M-CAN = engine CAN (CAN C, 500 kBit/s) D-CAN = diagnostics CAN (500 kBit/s)
Tire pressure monitor ¹ Electronic restraint system Overhead control panel ¹ Signal acquisition and actuation module Door control unit Fuel-fired heater booster ¹ Upper control panel Trailer control unit ¹ Park-tronic ¹ Programmable special module ¹ Air-conditioning control ¹ PTC heater booster ¹ Auxiliary heating, water ¹	CD changer ¹ Telephone ¹	Brake system Jacket tube module Electronic selector lever module ¹ Transmission selector lever Module ¹ Transmission control unit ¹ Engine control unit Sensor cluster Ax/Ay/wz Diagnostic interface Reduction control unit ¹

- ¹ Optional equipment
 A Head unit/radio, interface between I-CAN and MOST
 B Electronic ignition switch, interface between I-CAN and M-CAN
 C Instrument cluster, interface between I-CAN and M-CAN

Warning

As all components are networked and internally monitored. Do not connect to or modify components on the CAN bus (e.g. breaking, extending, or tapping). Any modifications to the length, cross-section or resistance of the wiring harness can lead to failure of safety-relevant components or to impaired comfort and may cause serious injury or death.

Internal and external vehicle diagnosis can be carried out by means of the OBD diagnostic socket (SAE 1962). All control units are capable of self-diagnosis and have an internal malfunction memory.

Communication with the relevant control unit can be established using the MB STAR DIAGNOSIS and the software developed for this unit.

You can obtain more information from an authorized SPRINTER Service Center or SPRINTER ENGINEERING.

6.4.2. Electric wiring/fuses

If the routing has to be altered, avoid routing across sharp edges and through narrow cavities or near moving components.

Only lead-free PVC-sheathed cables with an insulation limit temperature of > 105 C [221°F] may be used. Connections must be made by qualified personnel.

The electrical wire harness must be dimensioned according to the expected current drawn and protected with fuses.

Please use the following table as reference with an insulating limit temperature of > 105 °C [221°F].

Max. permanent current intensity (A)	Fuse rating (A)	Conductor cross-section (mm ²) [AWG]	
0 - 4.9	5 ¹	0.5	20
5 - 9.9	10 ¹	1	17
10 - 18	20 ¹	2.5	13
19 - 28	30 ¹	4	11
29 - 35	40 ²	6	9
36 - 48	50 ²	10	7
49 - 69	70 ²	16	5
70 - 98	100	25	3
99 - 123	125	35	1
124 - 148	150	50	0 (1/0)

¹ Shape C; DIN 72581 blade connector

² Shape E; DIN 72581 blade connector

6.4.3. Additional power circuits

If additional power circuits are installed, they must be protected against the main power circuit by fuses of adequate rating. The dimensions of the wiring used must be adequate for the load and the wiring must be protected against the effects of tear, impact and heat.

6.4.4. Control Switches

There are a total of eight switch locations available for additional special purpose bodies and equipment.

6.4.5. Retrofitting electrical equipment

Please observe the following if auxiliary electrical components are retrofitted:

- Alternators with LIN technology approved by Daimler AG must be used for high current draw requirements.
- Do not connect additional alternators to the onboard network.
- Do not connect additional components to fuses already assigned
- Do not connect additional wires (e.g. with insulation piercing devices) to existing wires.
- Provide components with adequate protection by means of additional fuses.

All equipment fitted must be tested in accordance with Electromagnetic Compatibility. Additional electrical components must be connected using the aux electrical connector (EK1) available from the factory as described in the "Power supply" section.

If the vehicle's electronics are modified or additional equipment is installed incorrectly, this may impair operating safety, cause damage to the vehicle's electrical system or the complete vehicle, and invalidate the vehicle's warranty/certification.

6.4.6. Retrofitting an alternator

If additional electrical components are retrofitted, the increased power requirement can be met by fitting an auxiliary alternator.

As of MY 2010 all Mercedes-Benz and Freightliner Sprinters are delivered with a 220 AMP alternator

Alternator:	U (V)	I (A)
Standard	14.3	220

If additional equipment is fitted, factory-fitted power take-offs must be used (→ chapter [7.5.3](#)).

For retrofitting one additional alternator, we recommend option N62 from the factory as optional equipment.

The following points must be observed if you intend to have other alternators retrofitted:

- Do not install an aux alternator that can impair vehicle parts or their function.
- The battery must have sufficient capacity and the alternator must generate sufficient power.
- The alternator circuit must be provided with additional fuse protection.
- The additional pulley, option N62, is available from the factory as optional equipment for driving aux alternators.
- Electrical lines must be routed correctly (→ chapter [7.3.5](#))
- There must be no impairment of the accessibility or easy maintenance of installed equipment.
- There must be no impairment of the required engine air supply and cooling (→ chapter [7.3.3](#)).
- The guidelines of the equipment manufacturer for compatibility with the basic vehicle must be observed.
- The operating instructions and the maintenance manual for the additional equipment must be supplied on delivery of the vehicle.

A new generation of regulator is used in the new SPRINTER. The alternator regulator is equipped with a LIN (Local Interface Network) interface.

The characteristics of the LIN alternators are fixed in the engine control unit – for this reason the **OEM alternator can not be replaced by an aftermarket alternator.**

The standard equipment for the SPRINTER is 220A.

No D+ (engine running positive signal) output available at alternator with LIN Bus technology, only at Bodybuilder socket EK1 under driver seat.

6.4.7. Power supply

Additional electrical components must be connected using an auxiliary electrical connector (EK1) standard from the factory. The electrical connector is installed inside the driver's seat base (at the front, on the left-hand side of the vehicle) and has three terminals:

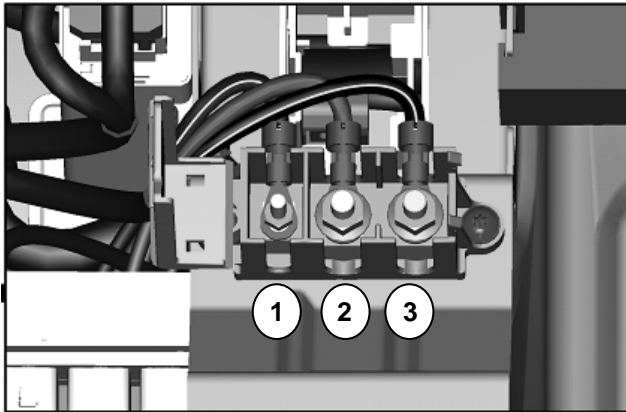

Terminal	U [V] / I [A]	wire color
1 st power with engine running	12V / 10A	blue/yellow
2 nd battery direct power	12V / 25A	red/gray
3 rd ignition power	12V / 15A	black/yellow

When installing electrical aftermarket equipment with an AMP draw of more than 25A it is necessary to use the optional aux battery 12V/100Ah (CODE E28).

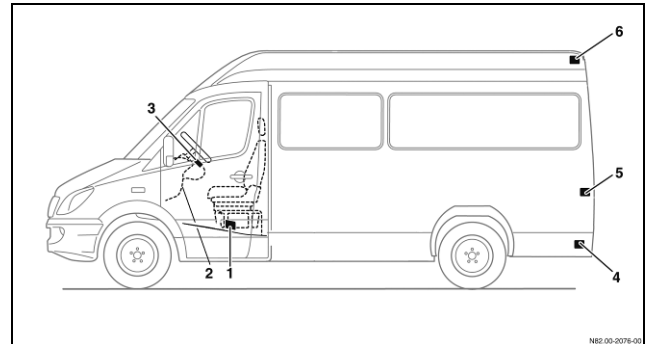

#	Option	Description
1	EK1	Auxiliary electrical connector (standard)
2	E46	12 V socket in instrument panel (max. 15 A) (standard)
3	L72	Connector for body int. lights (Chassis Cab only)
4	V08 / E58	Electrics for trailer power socket
5	L76	Extended tail lamp wiring harness (Chassis Cab only)
5	L77	AUX 12 V Plug Rear Comp (Van only)
6	LB2	Additional electrical equipment

6.4.8. Power supply Aux Battery

If a factory supplied auxiliary battery (option E28) is fitted a connector terminal is already fitted inside the driver seat. When using this terminal, no necessary wire routing from the aux battery is required.

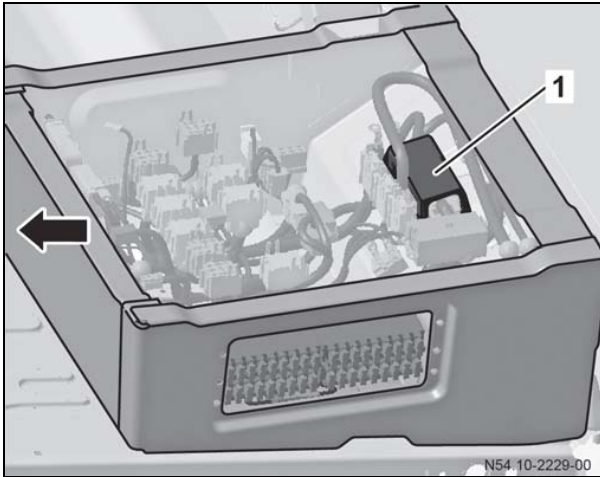

Driver seat pedestal

1	connector terminal
Arrow	driving direction

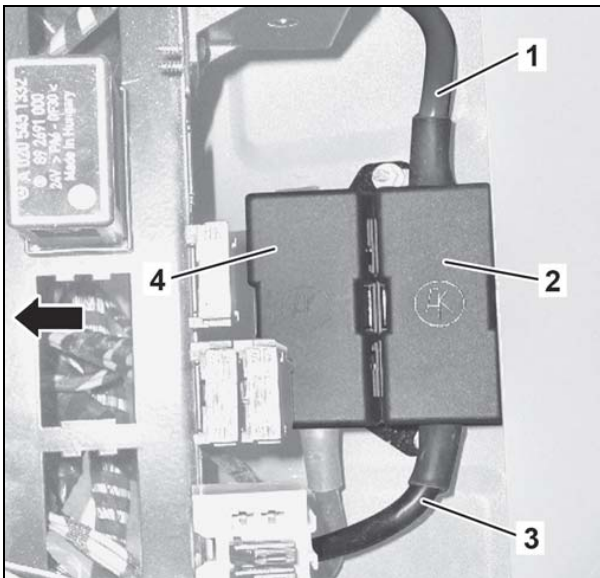

Example fuse box layout

1	wire from cut-off relay
2	Fuse box
3	wire to aux battery
4	additional fuse box (option EV3 only)
Arrow	driving direction

Fuse box ex factory with aux battery (E28)

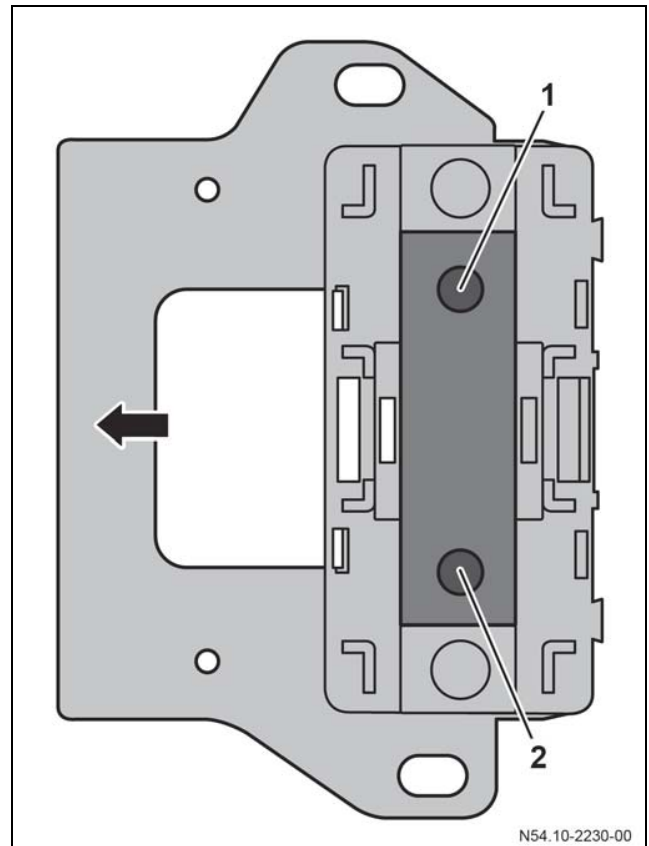

Fuse box (opened)

1	wire from cut off relay
2	12V take off from aux battery
Arrow	driving direction

6.4.9. Speed Signal

The “Highline” and “Lowline” instrument clusters output an electronic speed signal at pin 9 of the instrument cluster connector.

The speed signal (positive to ground) acts as a distance and speed signal for external electronics, e.g. taximeters or speed-dependent volume controllers.

The signal is protected against short-circuit to ground and battery voltage and is not monitored. The signal is output at 4 pulses per meter. The pulse width is 4 ms.

At 112.5 km/h [70 miles/h], the pulse duration is the same as the pulse pause. This 1:1 ratio is maintained for higher speeds. This means that, at higher speeds, the pulse length and the pause length become shorter at the same time.

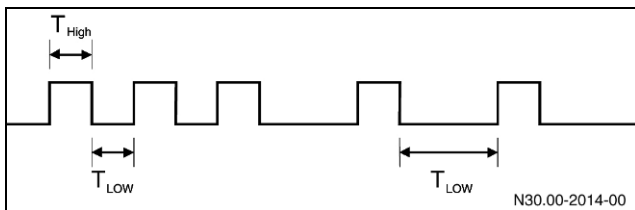

Ratio of pulse duration/pulse pause

Speed signal ($I_{\max} = 20 \text{ mA}$):

$T_{\text{high}} \quad U_a > = 8\text{V}$
 $T_{\text{low}} \quad U_a < = 1\text{V}$

6.4.10. Ground Connections

The ground bolts provided by the OEM for retrofitting electrical attachments or installations must be used to ensure the optimum ground connection with the basic vehicle. There are two M6 ground bolts in the seat base of the co-driver’s seat; there is an additional M6 ground bolt on the underside of the vehicle on the cross member to the front of the rear axle.

- No more than 4 cable connectors may be screwed onto one ground bolt.
- The nuts must be tightened to a torque of 6 Nm / [4.4lft-lbs]
- The use of any other ground bolts may lead to malfunctions in safety systems.
- The ground bolts of the safety systems must not be used for bodies.

For other requirements, please consult with SPRINTER ENGINEERING (→ chapter 2.7)

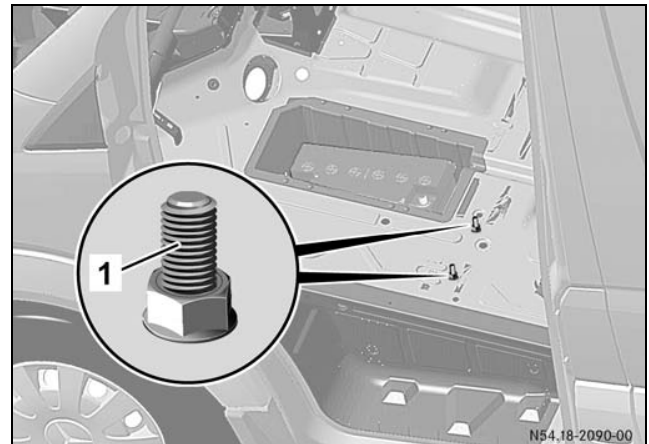

Cab ground connection (inside driver’s seat base)
 1 ground bolt connection

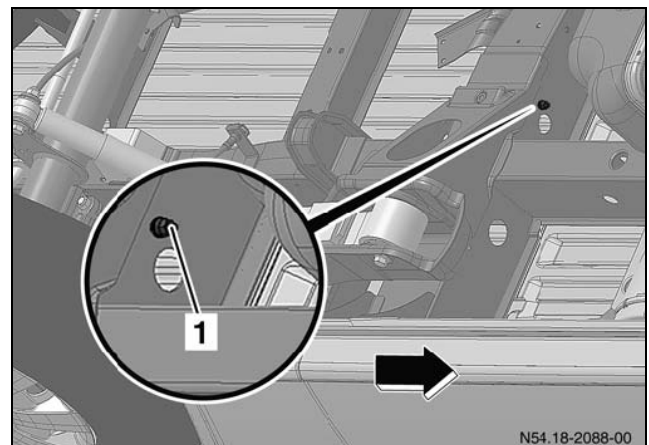

Frame ground connection in front of rear axle (8550 GVWR)

1 Ground bolt connection
 Arrow Front of vehicle



Chassis Cab Ground Terminal

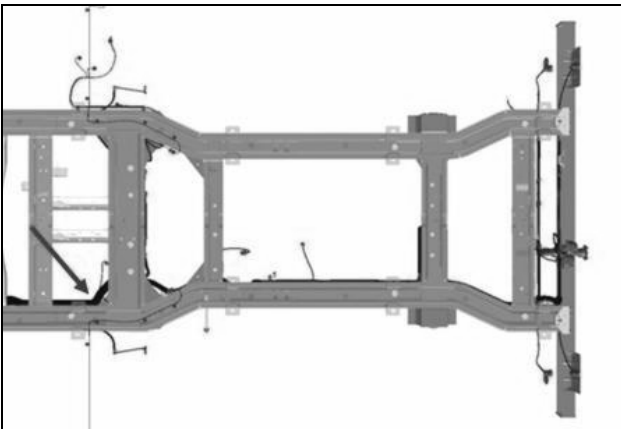

Location of Chassis Cab Ground Terminal

6.5. Lighting

6.5.1. Adjusting the Headlamps

The headlamp basic setting must be observed (see vehicle identification plate). Only check the headlamp setting with the vehicle unloaded (ready to drive—full tank and with the driver or 165 lbs load).

- Park the vehicle on a level, horizontal surface.
- Align the headlamp beam adjuster and the vehicle perpendicular to each other.
- Correct the tire pressures (refer to the tire pressure table).
- Switch on the headlamps.
- Check each headlamp separately; when doing so, cover the other headlamp and lights.

The light-dark boundary of the low-beam headlamp at a distance of 10 m [32.8ft] can be calculated from the height of the headlamp (center of headlamp to ground) minus the specified headlamp basic setting.

Bi-xenon headlamp basic setting

The basic setting on vehicles with bi-xenon headlamps must be adjusted by an authorized SPRINTER Dealer using MB STAR DIAGNOSIS tool.

Headlamp basic setting:

1% = 10 cm, 1.5% = 15 cm, 2% = 20 cm
 [1% = 3.9 in, 1.5% = 5.9 in, 2% = 7.9 in]

Warning

There is a risk of fatal injuries from the high voltage in the xenon headlamps. Do not touch any components under high voltage which may cause serious injury or death.

On no account may persons with electronic implants (e.g. pacemakers) carry out any work on xenon headlamps which may cause serious injury or death.

6.5.2. Tail lamps

Observe FMVSS/CMVSS standards.

The following optional equipment is available from the factory as option codes to carry out retrofitted modifications to the vehicle tail lamps.

Option	description	Description/function
L90	Omission of tail lamps	Possible to retrofit other lamps and turn signals; the connectors and wiring harness are retained
L76	Tail lamp wiring	The lengthened tail lamp wiring harness approx. 2m [6 ft]) acts as provision for retrofitting tail lamps in a different location
L77	Additional electrical equipment for turn signal lamps	On Chassis Cab the additional wiring at the vehicle rear end is provided for additional turn signal lamps on the body.

6.5.3. Marker Lamps

Vehicle clearance lamps/identification lamps

Clearance lamps increase passive safety and are required by law on vehicles with a width of 80 inches and wider. The 5 clearance lamps/identification lamps are standard equipment.

6.5.4. Exterior lamps

In order to ensure that the standard bulb failure monitor functions correctly, only bulbs of the same type and same output rating as standard bulbs may be installed.

On Chassis Cab starting MY2009 the lamp out feature is disabled.

Lamp monitoring

The signal acquisition and actuation module (SAM) monitors all outputs for open load (wire break) and short circuit. If a lamp is not connected or is overloaded, a fault entry is stored in the memory of the SAM control unit.

The fault entry must be addressed by an authorized Mercedes Benz SPRINTER & Freightliner SPRINTER service dealer with a MB STAR DIAGNOSIS.

Additional Lamps

Additional lamps must be connected via the PSM or a separate cubic relay. A standard cubic relay ($R_i > 80$ Ohms) can optionally be connected in parallel with the exterior lamps (with the exception of the third brake lamp, turn signals, license plate illumination side markers and perimeter lamps). This will not have any negative effect on lamp monitoring.

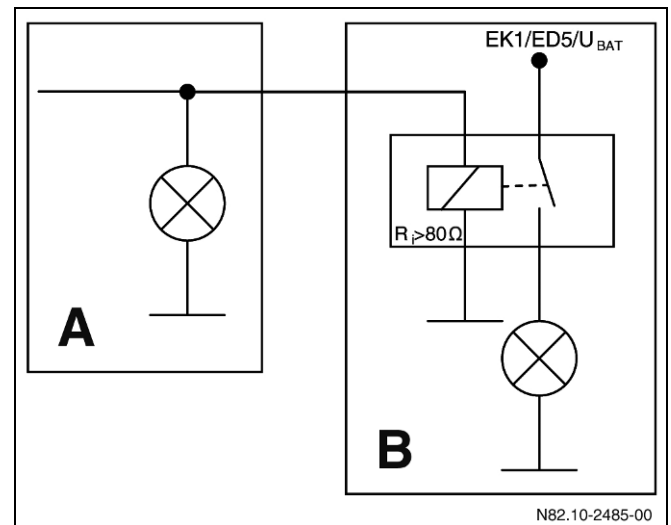

Connection of an additional lamp

- A Scope of the basic vehicle
- B Scope of the body builder

A warning buzzer can be optionally connected in parallel with the reversing lamps. The current rating of the warning buzzer must be no more than 300 mA. We recommend the use of a warning buzzer with piezo technology.

The third brake lamp is an LED with a rating of approximately 1.8 W and cannot be replaced by an incandescent bulb.

6.5.5. Interior Lamps

All interior lamps can be replaced by other body-manufacturer-specific lamps. The interior lamps are operated via read-back switches networked by the SAM (signal acquisition and actuation module). Monitoring is only carried out for short circuits, maximum load 80W. Lamps are normally switched on dimmed. Dimming must be deactivated in the SAM if fluorescent lighting or load relief relays are used. This is achieved by means of the "Working Lamps" option (Option L68). The read-back switch must always be connected to the SAM, otherwise the interior lamps cannot function.

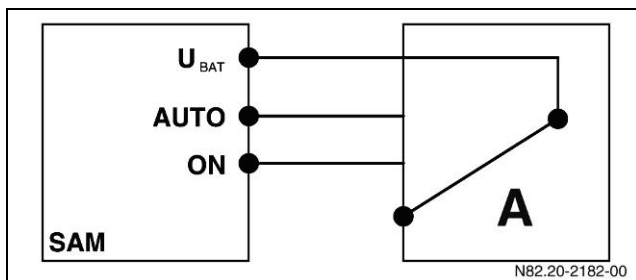

Read-back switch switching principle

U_{BAT}	Interior lightning power supply (+ 12 V)
AUTO	Lighting controlled by SAM, e.g. when door opened
ON	Interior lamp permanently lit
A	Read-back switch (interior lighting)

6.5.6. Rain-light sensor

It is only permitted to fit the rain-light sensor (Option JA5) in conjunction with the standard/optional WSS variants provided. There is otherwise a risk of malfunction.

The standard ceiling light has to be replaced by an overhead console with lights. The overhead control panel (DBE, Option LD0) must also be fitted (contains the interface).

6.5.7. Aftermarket tail light installation

When installing aftermarket tail lights it is necessary to have Lamp Out Recognition disabled. This is standard for Sprinter MY2009 and later.

This example was done with readily available aftermarket sealed polycarbonate lens & housing with incandescent dual filament bulb. The Stop, Turn and Backup light had 2.1 Amp @ 12.8 V and the Tail Light had 0.48 Amp @12.8 V.

Note:

Verify that the lower draw Tail lights are hooked up to the correct wire otherwise rapid flashing will occur. (Sometimes battery needs to be disconnected to reset.)

LED: When using LED's, a resistor must be used to compensate for the lower AMP draw. Turn signal LED's AMP draw must be between 1.75 A – 2.1 A otherwise rapid flashing will occur.

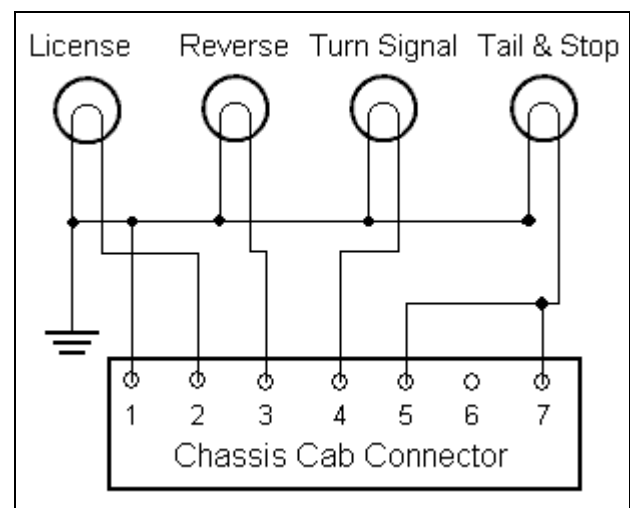

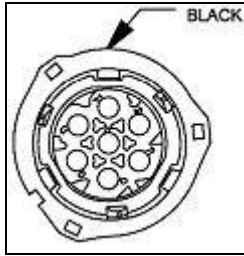

Chassis Cab Connector

LAMP-TAIL-LEFT

Cavity	Color	Function	max. Amp	Extension Cable (L76) Color
1	BR	Ground		BR
2	GY/DG	License Light	1.0A	DG
3	WT/DB	Backup Light	2.4A	WT/DB
4	BK/WT	Turn Signal	2.1A	BK
5	BK/RD	Stop Light	2.4A	RD
6	GY/BR	Fog Light	N/A	GY/BR
7	GY/BK	Tail Light	1.0A	GY

LAMP-TAIL-RIGHT

Cavity	Color	Function	max. Amp	Extension Cable (L76) Color
1	BR	Ground		BR
2	GY/DG	License Light	1.0A	DG
3	WT/DB	Backup Light	2.4A	WT/DB
4	BK/DG	Turn Signal	2.1A	BK
5	RD/BK	Stop Light	2.4A	RD
6	-	-	-	GY/BR
7	GY/RD	Tail Light	1.0A	GY

Note:

Wire colors on CODE L76 "Tail Light Extension Cable" have different colors (see tables).

Cable Color Abbreviations

BR	Brown
GY	Grey
DG	Dark Green
WT	White
DB	Dark Blue
BK	Black
RD	Red

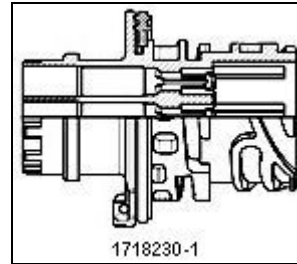

Male Connector

Fitting male connector: company Tyco
(www.tycoelectronics.com)

Connector: 1718230-1

Terminal: 1703014-1

6.6. Mobile communication systems

If mobile communication systems (e.g. telephone, CB radio) are retrofitted (→ chapter [4.6.3](#)), the following requirements must be fulfilled in order to avoid malfunctions developing on the vehicle at a later stage:

- All electronic equipment fitted requires type approval regarding electromagnetic compatibility.
- The ring-shaped MOST network uses a fiber-optic cable as a data carrier for transferring audio and control signals. This system supports the synchronous transfer of data at high baud rates, is insensitive to electromagnetic interference (EMC), does not cause electromagnetic interference and can transfer both audio and control data simultaneously. The system is available with the ignition OFF and is activated by a separate wake-up line.

Do not kink the fiber-optic cable. The minimum bending radius is 25 mm [1.0 inch].

6.6.1. Equipment

- The maximum transmission output must not be exceeded.

Waveband	Maximum transmission output (W)
Short wave < 50 MHz	100
4 m band	20
2 m band	50
Trunked radio / Tetra	35
70 cm band	35
GSM	10
3G	10

- Do not install mobile communications systems and brackets in the deployment area of the airbags (→ chapter [7.4.2](#)).
- The equipment must be permanently installed. Mobile devices may only be operated inside the cab if they are connected to an exterior aerial which has been installed in such a manner that it is reflection free.
- The transmitter unit must be installed as far away from the vehicle's electronic system as possible.
- The equipment must be protected from humidity and severe mechanical vibrations; the permissible operating temperature must be observed.

6.6.2. Connecting and routing the wiring for the radio antenna

- Comply with manufacturer's notes and installation instructions.
- The connection should be made directly to terminal 30 via an additional fuse. Disconnect the unit from the electrical system before jump-starting.
- The wiring routes must be kept as short as possible. The wires must be twisted and screened (coaxial cable). Chafing points must be avoided.
- Ensure that the system has a good ground connection to the body (aerial equipment).
- The antenna and connecting cables between the transmitter, receiver and operating panel must be routed separately from the vehicle wiring harness in the vicinity of the body ground.
- Route the antenna cable in such a way that it is not kinked or pinched.

6.6.3. Radio

5 Front Speakers (EL8)

This option includes a two-way loudspeaker system plus one center speaker. One mid-range woofer is fitted in the driver's door and one is fitted in the co-driver's door. The center speaker and the tweeters are integrated in the instrument panel. (Standard on cargo vans and chassis-cab with radio prep CODE ER0)

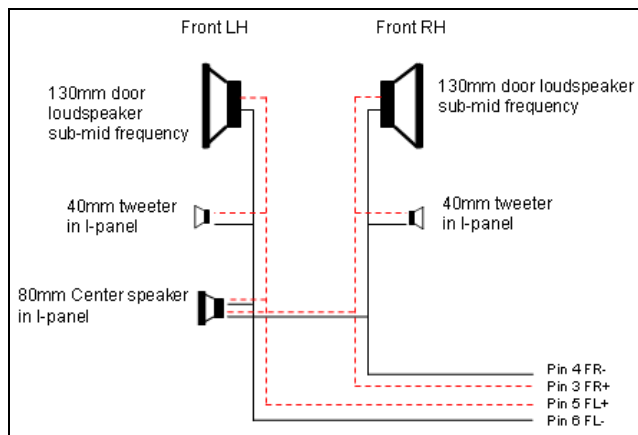

5 Front Speakers – Wiring Diagram (EL8)

5 Front, 8 Rear Speakers (EL9)

Two-way loudspeaker system: the 5 front speakers are extended with a further four tweeters and four mid-range woofers fitted in the sidewall/sliding door and in the left and right-hand rear side paneling in the passenger compartment. (Standard on passenger van with radio and passenger van radio prep CODE ER0)

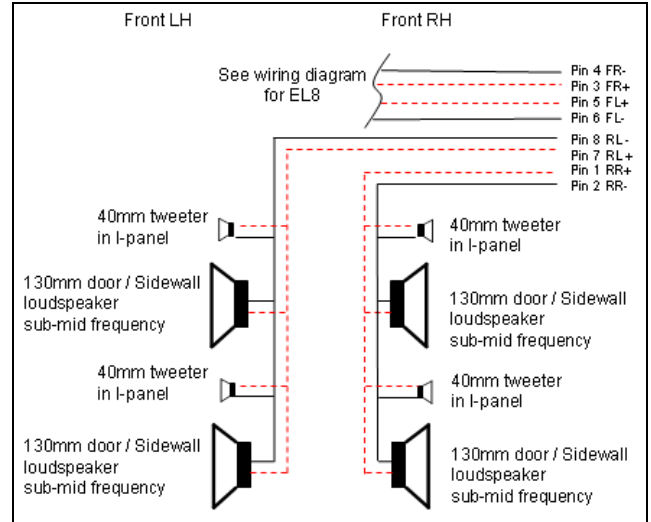

5 Front, 8 Rear Speakers – Wiring Diagram (EL9)

CODE ER0 pin layout radio connector

- A1 no connection
- A2 no connection
- A3 no connection
- A4 KI30 (+12V battery direct power)
- A5 switch 'Antenna'
- A6 terminal 58D (display illumination)
- A7 terminal 15R (ACC accessory power on)
- A8 KI31 (Ground)

- B1 Loud Speaker rear right +
- B2 Loud Speaker rear right -
- B3 Loud Speaker front right +
- B4 Loud Speaker front right -
- B5 Loud Speaker front left +
- B6 Loud Speaker front left -
- B7 Loud Speaker rear left +
- B8 Loud Speaker rear left -

Note:

If the radio was not setup for the eight rear speakers from the factory, a dealer must update the radio programming by activating a fader to activate the rear loudspeaker terminals.

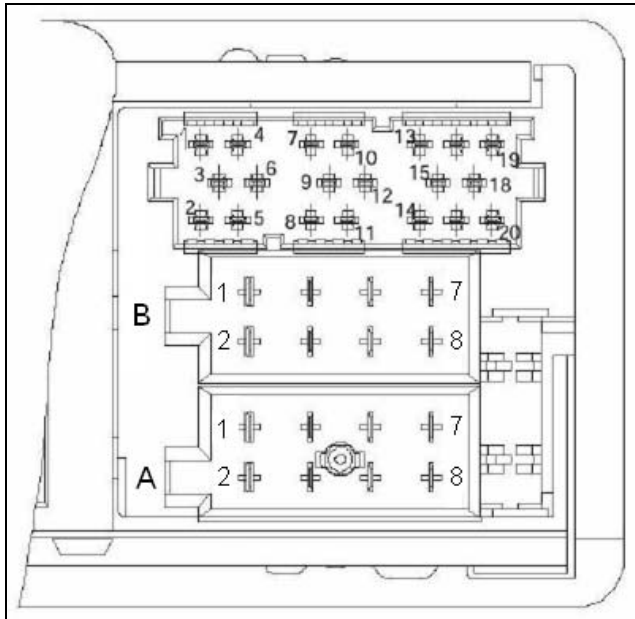
Rear View of Radio

Antenna Relocation

When relocating the roof antenna use:
 Antenna hole plug: A 906 820 01 12
 The plug is black and will be screwed onto the factory location. An extension cable for the antenna wiring (local supply) can be used to relocate the antenna. The antenna has to be properly grounded.

CODE ER0 Preparation for Radio Retrofit

Pre-installation for radio

Pre-wiring (12 V) for retrofitting a (commercially available) radio, plus short-range interference suppression and a flexible stub antenna on roof. Chassis Cab and Cargo Vans have 5 front loudspeakers (EL8), Passenger Vans come with 5 front and 8 rear loudspeakers (EL9).

Note:

The pre-installation for radio does not support CAN/MOST technology. After market radios will not work with highline steering wheel and cluster. Additional wiring must be retrofitted in order to retrofit a factory supplied radio. Without this wiring, functions such as recognition of the key position (radio continues to operate after the ignition key has been removed etc.) as well as control of the radio via the multifunction steering wheel and display of radio information in the instrument cluster are not supported.

As the factory-supplied radios are larger than the DIN slot, the radio opening must also be replaced when retrofitting a factory-supplied radio.

Preparation for Radio Retrofit

6.7. Electronic ignition switch (EZS)

6.7.1. General Information

- The processes involved in the access authorization for the central locking (ZV) are verified and controlled by the signal acquisition and actuation module (SAM) and the door control unit (TF).
- When the key is inserted, infrared communication with the radio remote control key is achieved by inductive energy transmission.
- When the radio remote control values are transmitted to the drive authorization system III (FBS III), the electronic steering lock (ELV) and the engine control unit are released.
- When the radio remote control key is removed, the ELV is locked if the last recorded speed signal was <3 km/h [1.86 mph] and the key is withdrawn by at least 4 mm. If the last recorded speed signal was >3 km/h [1.86 mph], the ELV is only locked if the door contact switch signals that the driver's door has been open for longer than 1 second.
- The radio remote control key activates the individual terminals (15, 15R) depending on the position in the ignition lock to which it is turned.
- The radio remote control key is mechanically locked when turned.
- If key identification is unsuccessful (invalid key), the lifting solenoid in the electronic ignition switch prevents the radio remote control key from turning.
- If key identification is successful, the memory functions are assigned.
- The electronic ignition switch acts as an interface (gateway) between the interior CAN (CAN B) and the engine compartment CAN (CAN C) for data exchange between the two bus systems.
- The diagnostics CAN acts as a central diagnostic interface with all control units with diagnostics capability.
- An HF receiver is integrated.
- Where control units are networked, the electronic ignition switch sends global information such as the model series and the country variant to the CAN-B and CAN-C control units (global variant coding) on the network.

6.7.2. Central locking/rescue vehicle

To guarantee faultless operation, it is only permitted to use central locking elements supplied by Daimler AG. If these cannot be used, please consult with SPRINTER ENGINEERING (→ chapter [2.7](#)) for further information. By means of EZS variant coding, the doors can be programmed to be present or not present. Activating automatic locking using MB STAR DIAGNOSIS Tool.

- Speed (adjustable, default 15 km/h [9.4 mph]).
- Ignition ON
- Automatic locking when last open door is closed (post function)

Deactivating automatic unlocking using MB STAR DIAGNOSIS Tool. On emergency vehicles it is possible to deactivate automatic central unlocking. This is a function that can be set by means of variant coding in the electronic igniting switch (EZS) using the MB STAR DIAGNOSIS Tool. You can obtain further information from SPRINTER ENGINEERING (→ chapter [2.7](#)).

Rescue vehicle fittings

The settings required for rescue vehicles, e.g. passive circuits for rear-door and sliding door actuators, can be carried out using MB STAR DIAGNOSIS Tool and using the following settings:

Right-hand sliding door "not present"
 Left-hand sliding door "not present"
 Rear door "not present"
 Common enable for control circuits 1 and 2
 Co-driver's door "not present"

6.8. Windows and doors

6.8.1. Power windows/window hinges

The gearing ratio for heavier windows must be adjusted to ensure that the motor draws the same electrical power. The time required to open/close the windows must not exceed 10 seconds. The motor is thermally protected i.e. the availability of the power window function may be restricted after long operating periods. The power windows and the window hinges can only be controlled using the door control panel. The switches are voltage coded and must only be replaced with equivalent genuine parts.

6.8.2. Load compartment sliding door

The electrical components of the cargo compartment sliding door. The cable track must be taken into consideration in the event of any modifications around the doorway. The cable track can be used for the requirements of the body builder following consultation with SPRINTER ENGINEERING (→ chapter 2.7).

On no account should modifications be made to the door kinematics or the locks, rails, carriages, closing aids and trap guard strips.

Correct operation of the integrated trap guard (trap guard strip and path/time monitoring) must be ensured in the event of any modifications in this area, e.g. the window installation.

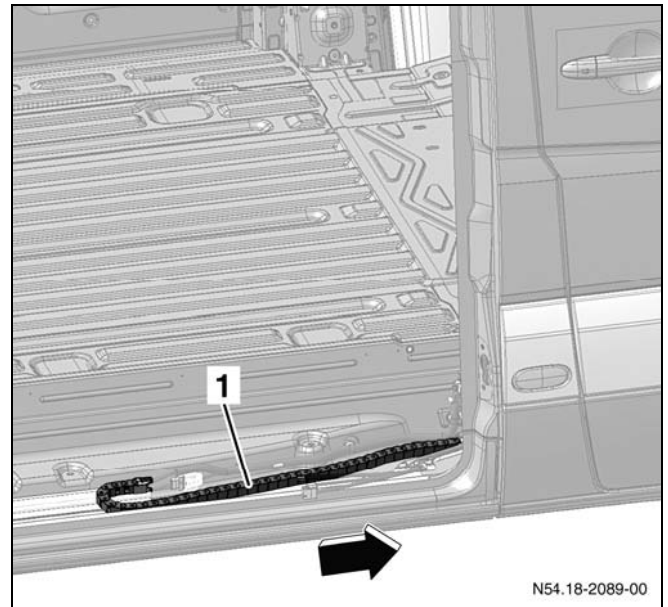

Load compartment sliding door with energy chain

- 1 Cable track (drag chain)
- Arrow Front of vehicle

6.8.3. Sliding sunroof

An OEM sliding sunroof can only be fitted in conjunction with an overhead control panel (DBE). The length of the wiring harness between the sliding sunroof motor and the DBE must not be more than 6 m [19.5 ft].

6.8.4. Windscreen wipers

We recommend the use of genuine OEM wiper motors. If necessary, a second wiper motor can be connected via a load relief relay ($R_i > 80$ Ohms). The wiper motor must be connected to the signal acquisition and actuation module (SAM) by means of a read back line. If only one wiper motor is connected, the SAM stores a fault in the malfunction memory.

6.8.5. Exterior mirrors

The output of the mirror heater (12 V / 20 W) is monitored by the door control unit. The mirror heating is deactivated if a fault entry is stored. The door control unit must be modified if different mirrors without a heater or with a different heater are used. The mirror adjustment is load switched and can be routed if required.

6.8.6. Windscreen heating/rear window heating

The original heaters can be replaced with heaters with the same power rating:

- Windscreen heating
P = 942 W+15% at 13 V
- Rear window heating
P = 2 X 151 W + 15 W at 13.5 V

If higher heat outputs are required, the relays, lines and fuses must be modified accordingly.

6.9. Electronic Stability Program (ESP)

ESP is a dynamic vehicle control system which controls both dynamic directional and transverse forces acting on the vehicle.

Greater driving stability is provided by ESP with an extended sensor system that constantly compares the current actual vehicle direction with the desired direction of movement.

ESP improves vehicle stability in all driving situations, e.g. when accelerating, braking and coasting, when driving in a straight line and cornering.

Together with the signals of other sensors, a processor monitors that the direction specified by the driver is maintained.

If the vehicle deviates from the correct path (over steering or under steering), The system produces a stabilizing counteraction by applying the brakes on individual wheels.

Warning

On no account may any of the following modifications be made to vehicles equipped with ESP:

- Modifications to the permissible gross vehicle weight
- Modifications to the wheelbase
- Modifications to the sensors (steering angle sensor, yaw rate sensor, wheel rotational speed sensor)
- Changes to the vibration characteristics at the installation location of the yaw rate sensor by modifications of the body.
- Changes to the position of components
- Modifications to the suspension
- Modifications to wheels and tires
- Modifications to the engine
- Modifications to the steering system
- Modifications to the brake system
- Conversion to a semi-trailer tractor vehicle

Modifications to vehicles with ESP may cause this system to stop functioning correctly and may lead to system shutdowns and incorrect control interventions. The driver could then lose control of the vehicle and cause an accident.

6.10. Signal acquisition and actuation module (SAM)

The power circuit on the SPRINTER comprises the signal acquisition and actuation module (SAM) in conjunction with a fuse and relay block (SRB). This power circuit supplies the systems and control units with power, depending on the function sequence. Requirements are sent to the SAM either on the CAN or via directly read switches and sensors. The fuses on the fuse and relay blocks also provide protection for individual components. You will find information about other functions in the "Technical details" section.

6.11. Parametric special module (PSM)

The PSM is the gateway to the CAN Bus. The PSM can be used to read and program vehicle functions.

The term “networking” refers to the interaction between different control units.

The PSM was developed to give body builders access to individual types of CAN bus data. The PSM is available with option code ED5 and can be retrofitted.

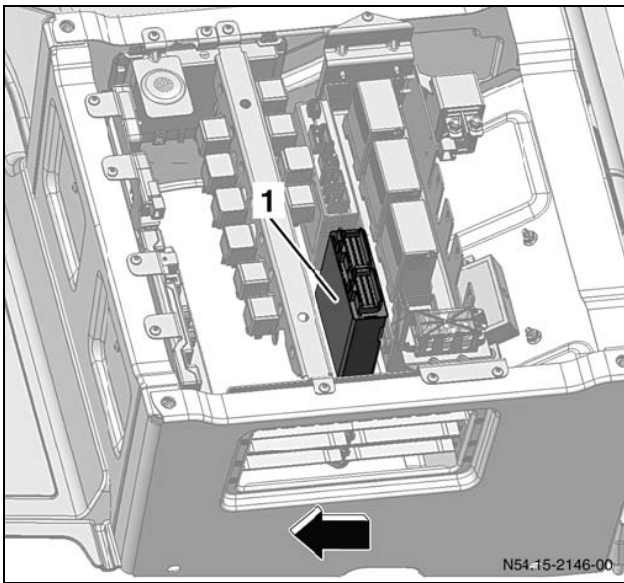

PSM location inside the driver's seat pedestal

Arrow Front of vehicle

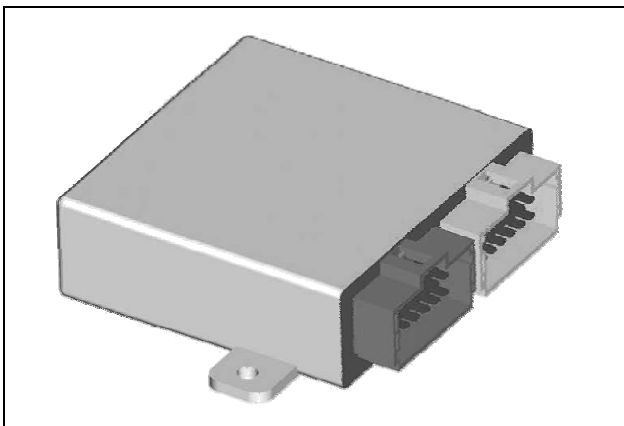

PSM Module

The PSM is able to read messages of the various bus data and translate them into signals. The outputs provide high, low or PWM (Pulse Width Modulation) signals.

The wiring on the vehicle can not be tapped, as this would lead to failure messages from other control units on the CAN bus.

The PSM provides a defined, diagnostic-compatible and EMC (Electro Magnetic Compatibility) -tested interface between the vehicle and the body.

Customer-specific requirements may be special inputs, or special outputs, such as pulse pause-modulated engine speed or CAN bus compatible control units in bodies or trailers.

Example:

The engine control unit sends the speed information to the PSM. The PSM converts speed information into a PWM signal and makes this available at an output.

When writing a standard coding, all previous parameters are deleted. We recommend a PSM data back up.

A PSM program is uploaded by using the dealer STAR Diagnostic Tool. Information about this can be obtained from your authorized SPRINTER dealer or SPRINTER ENGINEERING. For PSM programming, please contact SPRINTER ENGINEERING:

Name:	Walther F. Bloch
Dept:	SPRINTER Engineering Manager
Telephone:	(843)-695-5053
Fax:	(843)-695-5127
E-mail:	walther.bloch@daimler.com

Name:	Andreas J. Brockmann
	Support Engineer
Dept:	SPRINTER Engineering Support
Telephone:	(843) 695-5052
E-mail:	andreas.j.brockmann@daimler.com

6.11.1. Inputs/Outputs

Inputs:

A total of 10 inputs are available: 3 high active, 3 low active and 4 analog. The analog inputs can also be used as digital inputs.

Input devices can be:

- a) Switch
- b) Pushbutton

Outputs:

A total of 20 Outputs are available: this includes terminal 30 (+12 volt) and ground switch. Outputs values are in the range of 0.5A and 10A. All outputs are internally fused.

General information

- Short-circuit detection
- In the case of high-side outputs, the PSM provides (+12V). The consumer load must be connected to the body ground or battery ground.
- In the case of low-side outputs, the PSM provides (Ground)

6.11.2. Parameterization with Logic Blocks

PSM outputs and certain vehicle functions can be controlled by logical combinations of vehicle (CAN) signals and or switches

Logic contributions include:

- AND
- NAND (**not and**)
- OR
- NOR (**not or**)
- XOR (**exclusive or**)
- XNOR (**exclusive not or**)

Logic Blocks include:

- Timer Block
- Counter Block
- Flip Flop Block
- Threshold Switch
- Hysteresis Block

Logic combinations and logic blocks can be combined to reflect the desired function

Example:

The hazard warning buzzer turns on if

- a switch is activated
- the parking brake is not activated
- and the vehicle is in "Gear"

6.11.3. Contacts and pin allocation

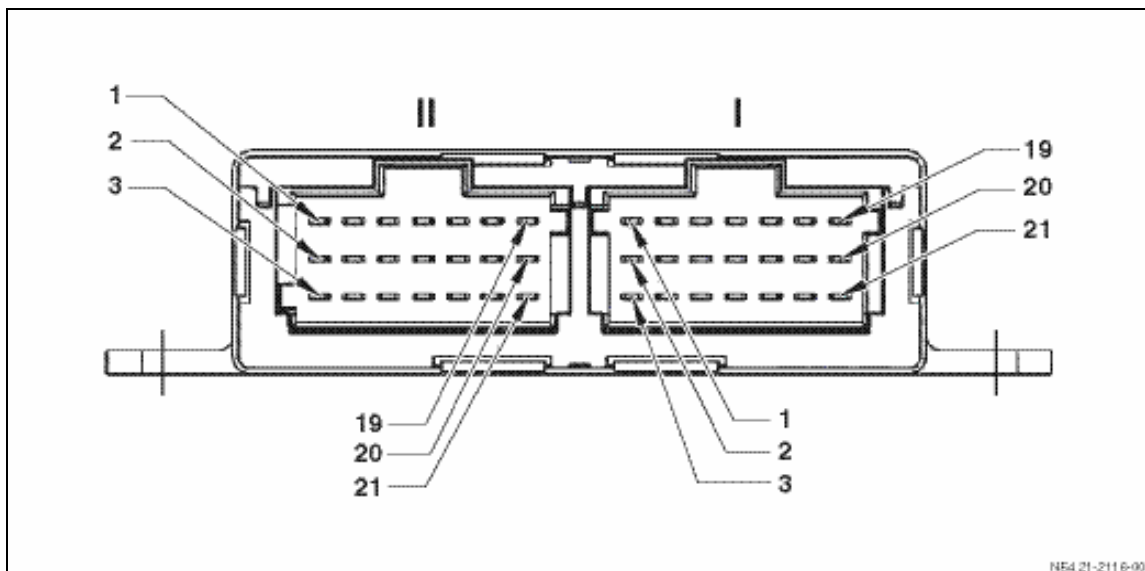

II Connector 2

- 1 Pin 1
- 2 Pin 2
- 3 Pin 3

I Connector 1

- 19 Pin 19
- 20 Pin 20
- 21 Pin 21

Connector 2

No.	Application
1	Input 6 low-active
2	Input 4 low-active
3	N/A
4	Input 1 high-active
5	Input 5 low-active
6	Input 2 high-active
7	Input 3 high-active
8	Input 7 analog
9	
10	Input 9 analog
11	Input 8 analog
12	
13	Output 1 H-bridge / 5A
14	Input 10 analog
15	
16	Output 2 H-bridge / 5A
17	Output 20 negative / 0.5A
18	
19	Output 19 negative / 0.5A
20	
21	

Connector 1

No.	Application
1	Not assigned/reserve
2	Output 18 Negative / 0.5A
3	N/A
4	Output 7 Positive / 5A
5	Output 17 Negative / 0.5
6	N/A
7	Output 8 Positive / 5A
8	Output 9 positive, PWM compatible / 1A
9	Output 16 Positive / 0.5A
10	Output 5 positive, wake-up capability / 5A
11	Output 10 positive, PWM-compatible / 1A
12	Output 15 Positive / 0.5A
13	Output 6 positive, wake-up capability / 5A
14	Output 11 Negative / 1A
15	Output 14 Positive / 0.5A
16	Output 3 positive, wake-up capability / 10A
17	Output 12 negative / 1A
18	N/A
19	Output 4 positive, wake-up capability / 10A
20	Output 13 Positive / 0.5A
21	N/A

6.11.4. PSM signals

Vehicle status	
Outputs	
	Clamping device
	Circuit 15R
	Circuit 15
	Terminal 50
	Terminal 61
	Emergency lighting switched on
	Hand brake applied
	Front interior lights switched on
	Rear interior lights switched on
	Vehicle moves
	* Battery voltage from EZS [EIS] electronic ignition switch
	* Outside temperature
	* Interior temperature
	* Vehicle speed
	* Fuel tank level

CAN	
Outputs	
	Selector lever in position "R"
	Selector lever in position "P"
	Selector lever in position "D"
	Selector lever in position "N"
	Anti-theft alarm system "armed"
	AC compressor switched on
	Crash signal received
	Audio muting
	Active starter lockout
	Motion detector has detected motion
	* Engine temperature

* Signals that can only be used to trigger outputs and can not deliver actual values.

Central locking	
Outputs	
	Left front door open
	Right front door open
	Sliding door or left crewcab hinged door open
	Tailgate or rear-end door open
	Left sliding door unlocked
	Right sliding door unlocked
	Tailgate or rear-end door unlocked
	Right front door unlocked
	Left front door unlocked
	Load compartment unlocked
	Cab unlocked
	Load compartment and cab unlocked
	Load compartment locked
	Cab locked
	Load compartment and cab locked
	Engine Hood is open
Inputs	
	Unlock vehicle
	Lock vehicle
	Unlock front doors
	Lock front doors
	Unlock load compartment
	Lock load compartment

Illumination and signaling horn
Outputs

Front fog lamp switched on
 High beam switched on
 Signaling horn operated
 Side lights switched on
 Low beam switched on
 Rear fog lamp switched on
 Hazard warning flasher (light phase) active
 Left turn signal (light phase) active
 Right turn signal (light phase) active
 Light sensor "Night"
 Daytime running lamps active
 Brake lights actuated

Inputs

Switch on front fog lamps (alarm)
 Switch on high beams (alarm)
 Synchronous flashing of front fog lamp and high beams (alarm)
 Switch on hazard warning flasher(alarm)
 Signaling horn operated
 Switch on left flasher
 Switch on right flasher
 Switch on high beam
 Switch on headlamp flasher
 Switch on hazard warning flasher
 Switch on buzzer
 Switch on front interior lights
 Switch on rear interior lights
 Switch on standing lights
 Switch on low beams
 Switch on fog lamps
 Switch on rear fog lamp
 Switch on signaling horn (alarm)

Indicators and warning indicators
Outputs

"Brake wear" indicator lamp switched on
 "Coolant level too low" warning lamp switched on
 "Washer fluid level too low" indicator lamp switched on
 "Brake fluid level too low" indicator lamp switched on
 Left low beam defective
 Right low beam defective
 Center high-mounted brake lamp defective
 Left stop lamp defective
 Right stop lamp defective
 Left turn signal lamp
 Right turn signal defective
 Left high beam defective
 Right high beam defective
 License plate lamp defective
 Rear fog lamp defective
 Left front fog lamp defective
 Right front fog lamp defective
 Left front parking lamp defective
 Right front parking light defective
 Backup light defective
 Left tail lamp defective
 Right tail lamp defective
 Left side-marker lamp defective
 Right side-marker lamp defective
 Clearance illumination defective
 Tank fill level in RESERVE

PWM signals (Pulse Width Modulation)
Outputs

Wheel speed
 Engine speed
 Vehicle speed
 Outside temperature
 Inside temperature
 Display dimming

6.12. Tire pressure monitoring system

Warning

Do not carry out any modifications in the grey-shaded areas of the vehicle substructure (see illustration). Otherwise, the function may be compromised by the effect of reflections. This might result in the driver being unaware of any tire pressure loss, and could cause an accident that may cause serious injury or death. Furthermore the vehicle will lose its certification.

Tire Pressure Monitoring System is only available on Mercedes Benz SPRINTER & Freightliner SPRINTER 2500.

Correct operation of the tire pressure monitor, or Tire Pressure Monitoring Systems (TPMS), can only be guaranteed if no modifications are made to the underbody (as the effect of reflections cannot be correctly evaluated). Modifying the vehicle substructure may adversely affect the tire pressure monitoring system.

The antenna position for the front axle is in the front of the engine compartment on the right-hand longitudinal member near the jack support bracket and behind the right-hand headlamp on the inside of the A-pillar.

The antenna position for the rear axle is to the rear on the underbody between the wheels (Cargo Van and Passenger Van). You can obtain more information about the tire pressure monitoring system from SPRINTER ENGINEERING (→ chapter [2.7](#)).

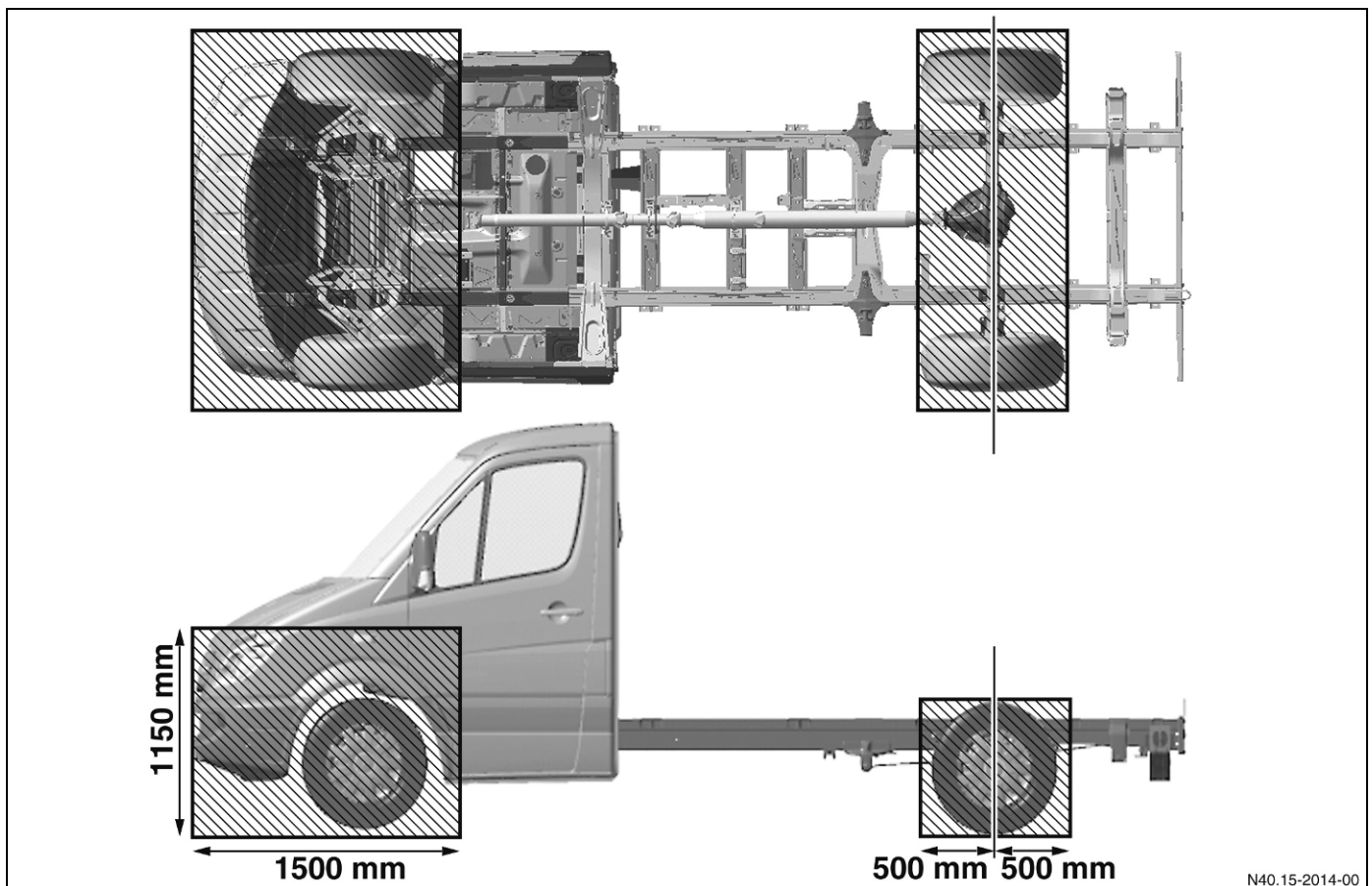

Restricted area for tire pressure monitoring system. TPMS only available on 2500 SPRINTERS. Picture above reflects 2500 SPRINTER Chassis-Cab for illustration purposes only.

6.13. Parktronic

- If approved attachments are retrofitted, it is necessary to have Parktronic coded with the appropriate parameter record by Daimler AG.
- After market painting of the bumper is not permitted with the Parktronic ultrasonic sensors fitted. The coat of paint impairs the emission and reception of the ultrasonic signals.

Sensors which are already painted must not be repainted or touched up. In order to ensure that they function correctly throughout their operating life, sensors must be painted before being installed. Unpainted sensors and sensors painted in a range of colors are available from your authorized SPRINTER Dealer.

The maximum thickness of paint on the cover may have without impairing sensor operation is 120µm. This also includes repeated painting applications and the coat of cathodic dip paint. The paint coat thickness is between 12µm and 25µm.

It is therefore necessary to make spot checks of the paint thickness to ensure faultless operation of the sensors.

It is essential that not only the cover itself but also the cylindrical edge of the sensor cover be coated with paint evenly all the way around and covering at least 2 mm.

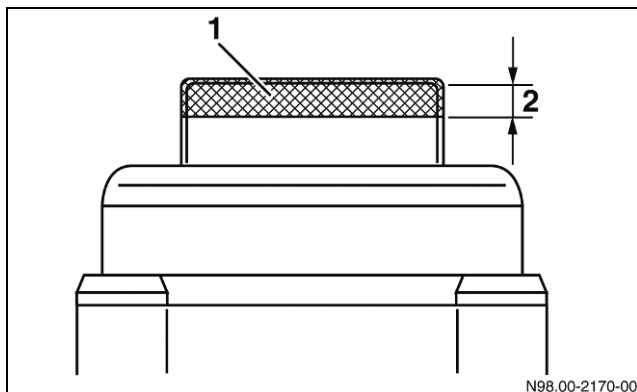

Area of cylindrical edge of the sensor cover to be painted

- | | |
|---|--------------------------------|
| 1 | Area to be painted |
| 2 | Maximum coat thickness 120 µm. |

The coat of paint may not be ground off mechanically, as this could damage the chromate layer or the cathodic dip paint layer or the sensor covering.

If the surface has been cathodically electro primed, the paint must not be removed by chemical means as this could damage the cataphoretic electroprimer layer. A new layer cannot be applied afterwards. Nor is it permitted to touch up damaged areas chemically or mechanically.

Attachment parts fitted in the detection range of the sensors may impair operation of the parktronic system (e.g. trailer hitch, overhangs of bodies, wheel carriers, steps, brush guards).

6.14. Rain / light sensor

On vehicle with bodies that protrude beyond the limit shown below (e.g. motor caravans with alcove bodies), the function of the rain / light sensor may be impaired. Therefore, it is not recommended to install a rain / light sensor on vehicles with bodies that protrude beyond this limit.

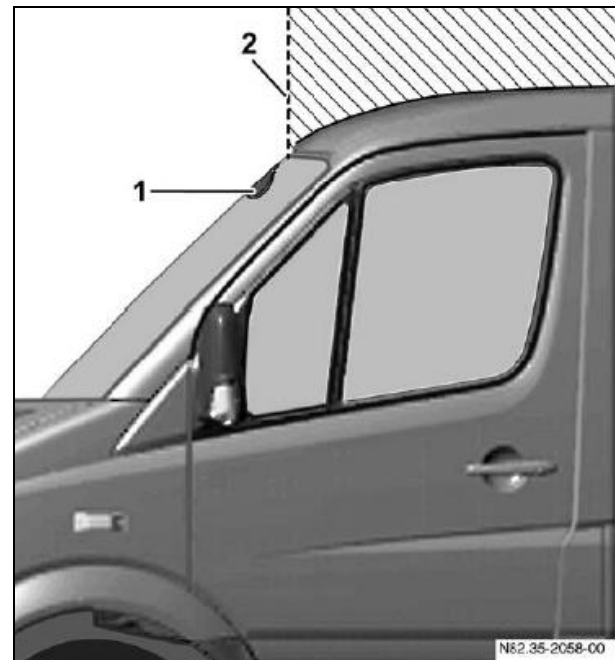

Limit for bodies on vehicles with rain / light sensor

On no account should any modification be made to the position of the rain / light sensor or the surrounding area (e.g. changing the standard wind screen), otherwise the rain / light sensor may no longer function correctly.

7. Modifications to the basic vehicle

7.1.1. General information on the suspension

Additional attachment parts are not permitted to be secured to the bolting points on the front axle.

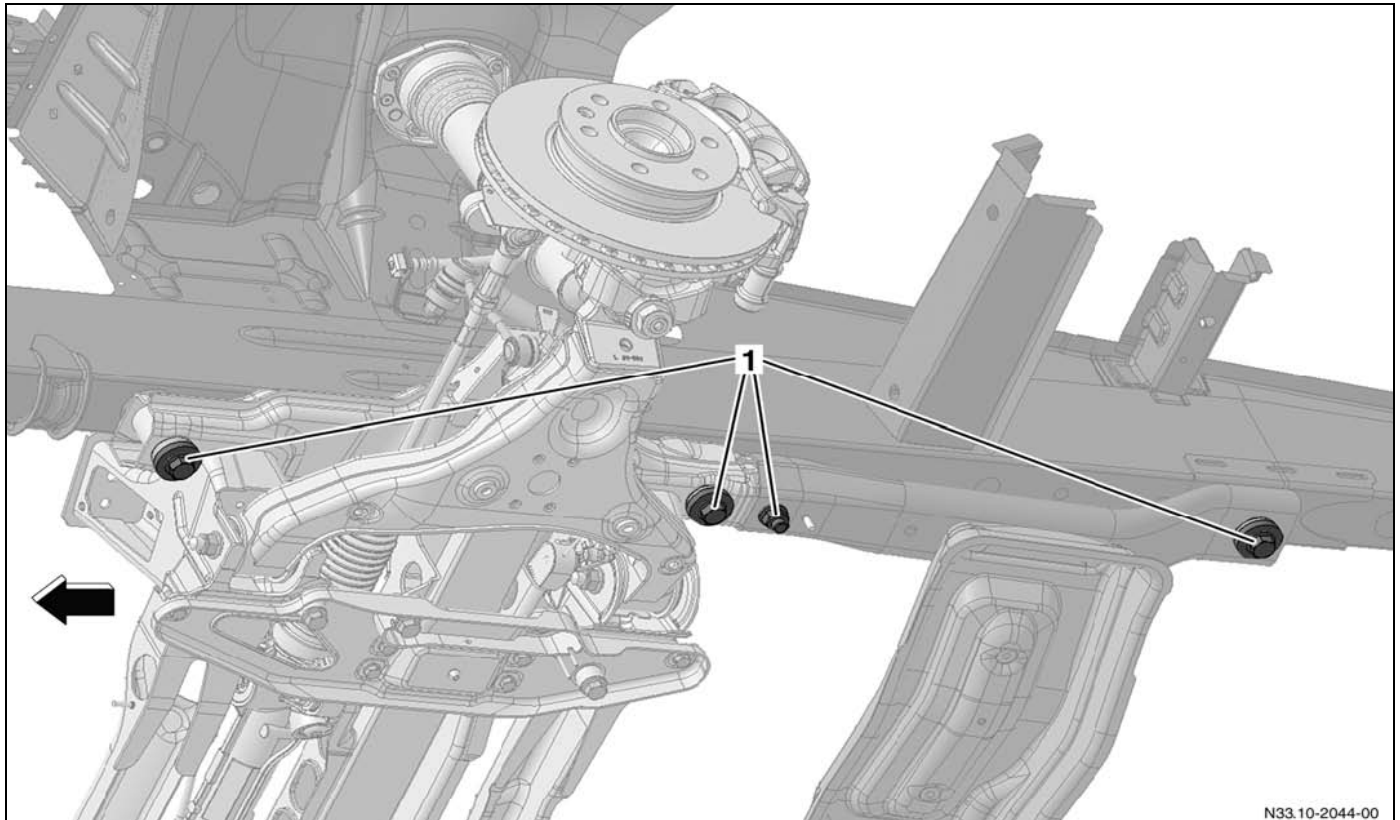

Front axle

1 Bolting points on the front axle

This is especially valid for:

- Front transverse link: Do not modify wheel position values
- Do not modify or use the front axle to mount additional equipment or make other modifications.

Arrow Front of vehicle

- Rigid rear axle: do not modify rear axle.
- Brakes: do not modify the brake system
- Do not modify: equipment, sensors, line routing for ESP/ABS.

Warning

Modifications to components of the suspension system can result in impaired and unstable vehicle handling characteristics. The driver may lose control of the vehicle and cause an accident that may cause serious injury or death. For this reason, no modifications whatsoever may be made to components of the suspension system.

Warning

Do not change any bolted connections that are relevant to safety, e.g. that are required for wheel alignment, steering or braking functions. They may otherwise no longer function correctly. The driver may lose control of the vehicle and cause an accident that may cause serious injury or death. Parts must be refitted in accordance with MB after sales service instructions and using suitable standard parts. We recommend the use of genuine MB SPRINTER parts.

- It is strictly prohibited to shorten the length of the free clamping bolt, change to the reduced shaft or use bolts with a shorter thread.
- The settling behavior of bolted connections must be observed.

Information is available from any authorized SPRINTER Service Center. Additional tensioned parts must be of equal or greater strength than the preceding tensioned assembly.

The use of MB tightening torques assumes coefficients of friction for the bolts in the tolerance range of $[\approx 0.08 \dots 0.14]$.

We recommend the use of standard MB SPRINTER parts.

7.1.2. Springs/shock absorbers/anti-roll bars

Modifications to springs, shock absorbers and anti-roll bars can only be made in the combinations specified by Daimler AG on the front and rear axle.

You can obtain more information from SPRINTER ENGINEERING (→ chapter [2.7](#)).

We recommend the use of genuine MB SPRINTER springs

- Do not damage the surface or corrosion protection of the spring leaves during installation work
- Before carrying out welding work, springs must be covered to protect them against welding spatter.
- Do not touch springs with welding electrodes or welding tongs.

On no account should springs and shock absorbers be used if they do not correspond to the characteristics of standard parts or parts obtainable as optional equipment. We recommend the use of standard MB SPRINTER parts.

Warning

On no account should springs and shock absorbers be used if they do not correspond to the characteristics of standard parts or parts obtainable as optional equipment. Otherwise, this system may no longer work correctly and could ultimately fail. The driver may lose control of the vehicle and cause an accident that may cause serious injury or death. Refer also to the optional equipment Information (→ chapter [3.9](#)).

7.1.3. Brake system

Warning

Work carried out incorrectly on the brake hoses, lines and cables may impair their function. This may lead to the failure of components or parts relevant to safety, the driver may lose control of the vehicle and cause an accident that may cause serious injury or death.

Have work on brake shoes, lines and cables only carried out by an authorized SPRINTER dealer.

Warning

Do not modify brake system components e.g. discs, calipers, sensors, etc. Any modifications to brake components may result in these systems not functioning correctly and ultimately failing. The driver may lose control of the vehicle and cause an accident that may cause serious injury or death.

Routing lines

Warning

A sufficient distance must be maintained between brake lines and heat sources, sharp-edged or moving parts. Otherwise, the brake system function could be impaired or the brake system could suffer total failure as a result of bubbles forming in the brake fluid or from chafing points in the brake lines the driver may lose control of the vehicle and cause an accident that may cause serious injury or death.

Routing lines along the brake hoses

- No other lines may be attached to the brake hoses.

Brake cable for the parking brake

- Do not modify the length of the brake cable.

Disc brakes

- Do not impair cooling by attaching spoilers below the bumper, additional hub caps or brake disc covers, etc.

Warning

Do not modify air inflow and air outflow of the brake system. Any modifications may result in these systems not functioning correctly and ultimately failing. The driver may lose control of the vehicle and cause an accident that may cause serious injury or death.

Brake system overheating will not only impair braking ability, it can also cause tire damage. For this reason, make sure that there is a sufficient supply of cooling air at all times.

7.1.4. Wheels and tires

Warning

Only fit tires of a type and size approved for your vehicle and observe the tire load-bearing capacity required for your vehicle and the tire speed index. In particular, comply with FMVSS/CMVSS regulations concerning the approval of tires. These regulations may define a specific type of tire for your vehicle. If you have other wheels fitted:

- The brakes or components of the suspension system could be damaged
- Wheel and tire clearance can no longer be guaranteed
- The brakes or components of the suspension system can no longer function correctly

The driver may lose control of the vehicle and cause an accident that may cause serious injury or death.

Gross vehicle Weight [lbs]	Wheel	Tire size	Load Index
8,550	6.5Jx16	245/75R16	120/116
9,990	5.5Jx16	215/85R16	115/112
11,030	5.5Jx16	215/85R16	115/112

The body builder must ensure the following:

- There must be sufficient space between the tire and the mudguard or wheel arch even with snow chains fitted and the suspension completely compressed (allowing for axle twist). The relevant data (→ chapter [7.2.6](#)) must be observed.
- It is only permissible to fit approved tire sizes see the vehicle documents, 2D drawings website (→ chapter [1](#)) or the above table.
- It is only permissible to fit approved wheels with the correct dimension & load rating document.

You can obtain more information about tires and wheels from any authorized SPRINTER dealer or in the “Optional equipment” section (→ chapter [3.9](#)).

7.1.5. Spare wheel

The SPRINTER is equipped with a spare wheel. When mounting a spare wheel, observe the following:

- Fit under the frame, on the side of the frame or on the body in accordance with the chassis drawing.
- Observe legal requirements
- It must be easily accessible and easy to handle
- It must be double – secured against detachment.

7.2. Body shell / Body

7.2.1. General information on the body shell/body

Modifications to the body must not have a negative effect on the function or strength of vehicle equipment or controls or on the strength of structural parts. In the case of vehicle conversions and mounting bodies, do not make modifications that affect the function or clearance of movement of chassis parts (e.g. during maintenance and inspection work) or accessibility to these parts.

Observe the following:

- The TPMS (Tire Pressure Management System) may malfunction if modifications are made in the direct proximity of the aerials and wheels.
- Do not modify the cross member structure from the front of the cross member through to the rear of the B-pillar.
- Do not modify the rear door opening or to the roof area.
- The clearance for the fuel filler neck, fuel tank and fuel lines must be maintained.
- Avoid sharp-edged corners.
- Do not drill holes in or perform welding work on the A-pillar or B-pillar.
- Do not cut in the C or D-pillar (rear door opening), including the associated roof arch.
- Do not exceed the maximum permissible axle loads.
- Trailer connections must be checked for correct operation.
- If a trailer hitch is installed, the necessary reinforcements must be present.
- Holes on the longitudinal frame member are the result of the production process and are not suitable for securing attachments, bodies, equipment and conversions as there is otherwise a risk of damage to the frame.

Section dimension of longitudinal frame members. (mm)

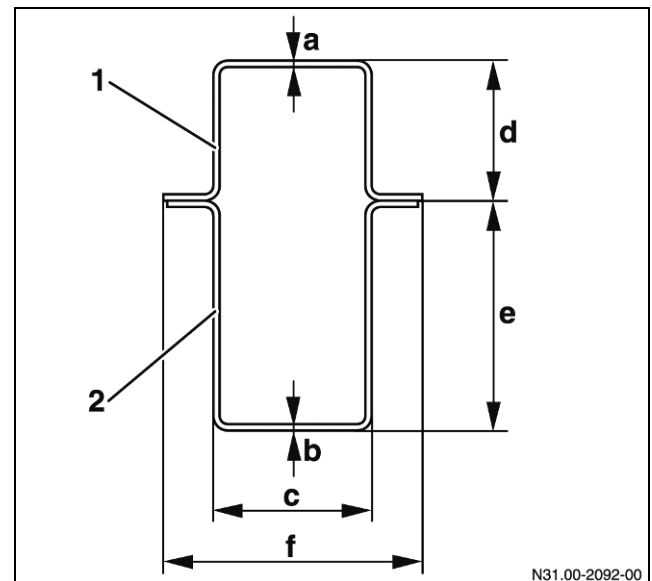

Dimensions of the upper chord and lower chord

- 1 Upper chord
2 Lower chord

Model	a	b	c	d	e	f
3500 Chassis Cab	3	3	70	80	120 100 ¹	126
2500 Cargo Van		1.5	70	-	120 85 ¹	93
3500 Cargo Van		3	70	-	120 100 ¹	118

Dimensions in [mm]

¹ In the area of the rear axle

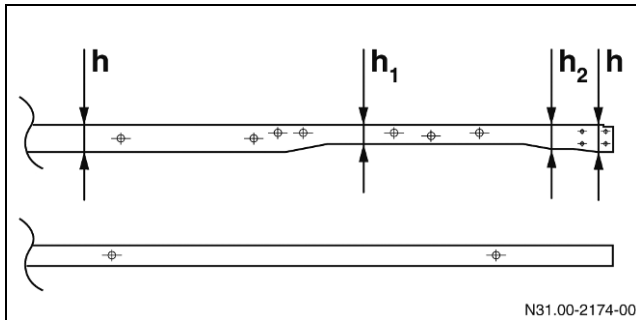
8,550 Longitudinal frame member

Dimensions of the lower chord of the longitudinal frame member

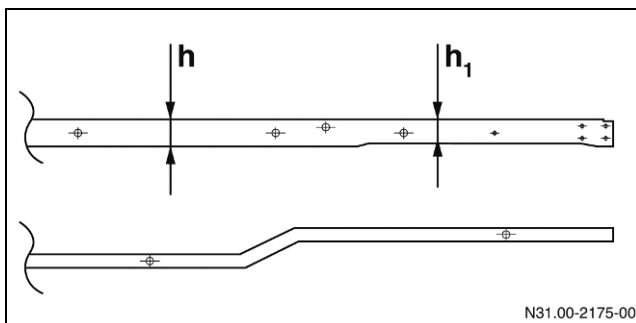
h	120 mm
h1	85 mm
h2	110mm

9,990 & 11,030 longitudinal frame member

Dimensions of the lower chord of the longitudinal frame member

h	120 mm
h1	100 mm

Welding work on the body shell

Welding work may only be performed by skilled personnel.

You will find further information about welding operations in the “Planning of bodies” (→ chapter [3](#)), “Damage prevention” (→ chapter [5](#)) and “Body shell” (→ chapter [7.2](#)) sections and in the SPRINTER Repair Manual.

Do not weld upper and lower chords of the chassis frame. Plug welding is only permissible in the vertical webs of the longitudinal frame member, contingent upon approval from SPRINTER ENGINEERING. Do not perform any welding work in bends.

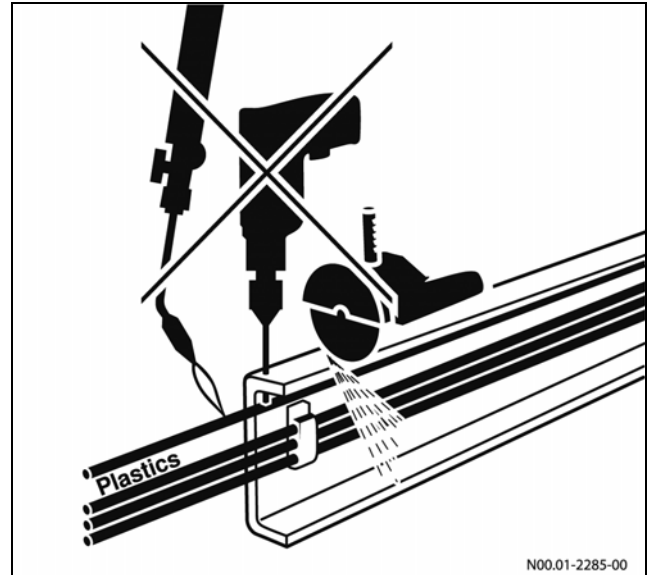

Warning

Unauthorized drilling or welding work carried out in the area of deployment of the airbags could cause them to function incorrectly, e.g. they could be triggered unpredictably while the vehicle is in motion or they might fail completely and in case of an accident may cause serious injury or death. For this reason, do not weld or drill near air bags.

Drilling work on the frame

Existing holes in the longitudinal frame member result from the production process and may only be used if approved by SPRINTER ENGINEERING (→ chapter [2.7](#)).

On completion of all work on the vehicle, you must comply with the specified corrosion protection measures (→ chapter [5.3](#)).

Do not drill holes:

- On the upper and lower chords of the frame (except if drill holes are at the rear end of the frame)
- In areas with a load-bearing function for the rear axle or parts fastened to the frame
- At load application points (e.g. spring supports, brackets, etc.)

7.2.2. Attachment to the frame

Attachment to the front frame section

On no account should assemblies, bars, etc. be secured near the frame fore-structure or the front axle as this may interfere with the necessary structure for passive safety.

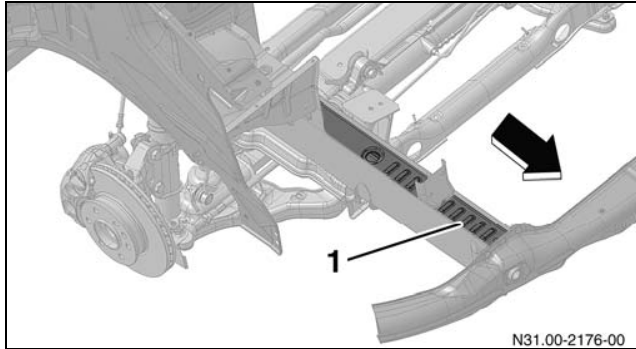

Structure for passive safety

1 crumple zone on the sub-frame
 Arrow Front of vehicle

Warning

If attachments are mounted on the front frame section, the function of the forward impact structure and the airbag units may be impaired and in case of an accident and may cause serious injury or death.

For the aforementioned reasons, do not install assemblies & bars to the front structure of the SPRINTER.

The modifications must not hinder possible repair work on the standard vehicle.

Attachment to the rear frame section

The attachment of additional equipment or bodies to the rear frame section must be equal to the attachment of the trailer hitch available as optional equipment. For the application of greater forces and moments, an additional support on the end frame cross member is required.

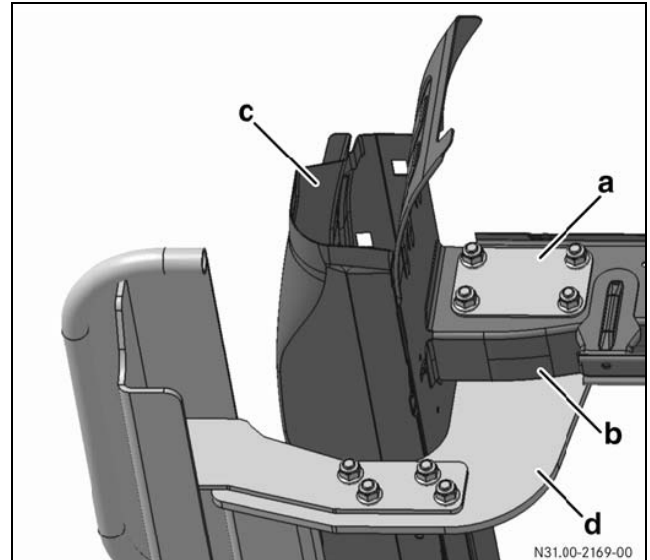

Outside view

- a Attachment of mounting plate to the longitudinal frame member
- b Lower chord of the longitudinal frame member
- c End frame cross member
- d Mounting plate for the trailer hitch

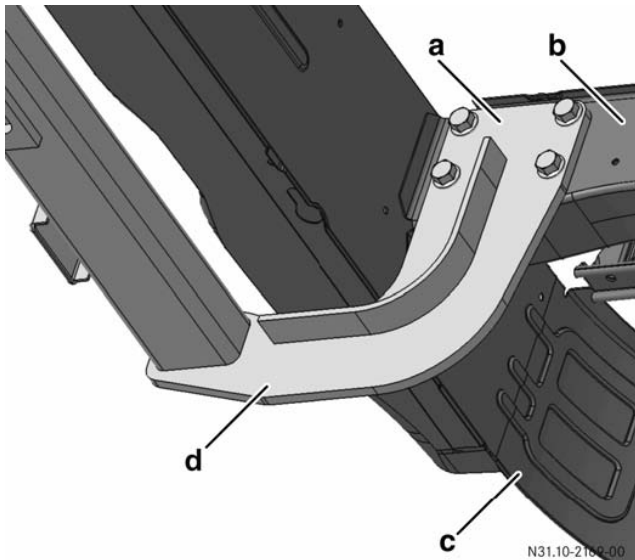

Inside view

- a Attachment of mounting plate to the longitudinal frame member
- b Lower chord of the longitudinal frame member
- c End frame cross member
- d Mounting plate for the trailer hitch

Attachments by means of body support brackets

The body support brackets fitted at the factory must be used for attaching bodies to the vehicle frame. More information is contained in the "Attachment to the frame" section (→ chapter [7.2.2](#)).

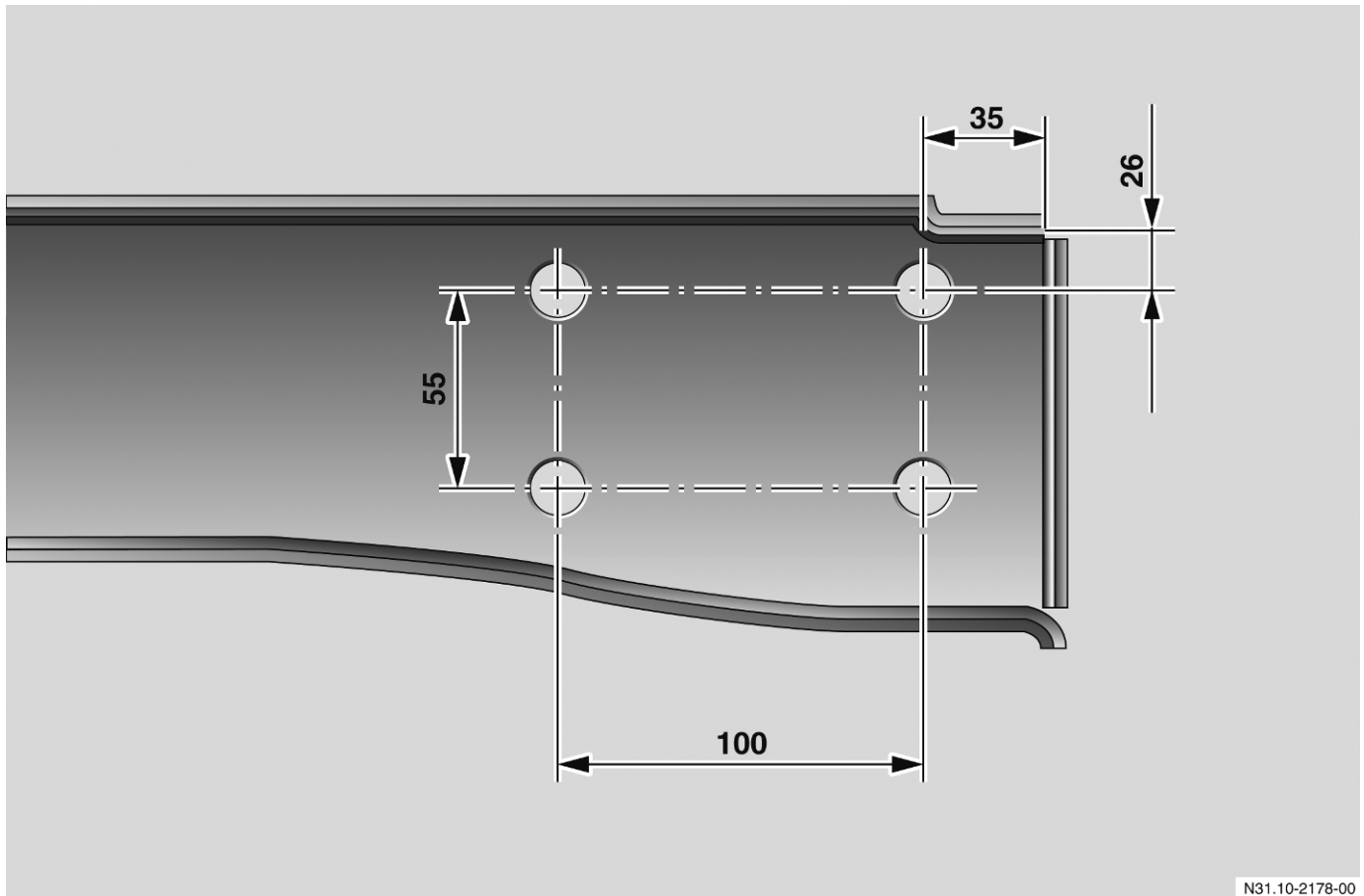
2500 and 3500 SPRINTER Cargo and Passenger Vans

N31.10-2178-00

Vehicle type	Wheelbase	Dim a	Dim x	Overhang
2500 and 3500 cargo and passenger vans	144 in 170 in	- -	- -	1150 mm / 45.3 in 1250 mm / 49.2 in

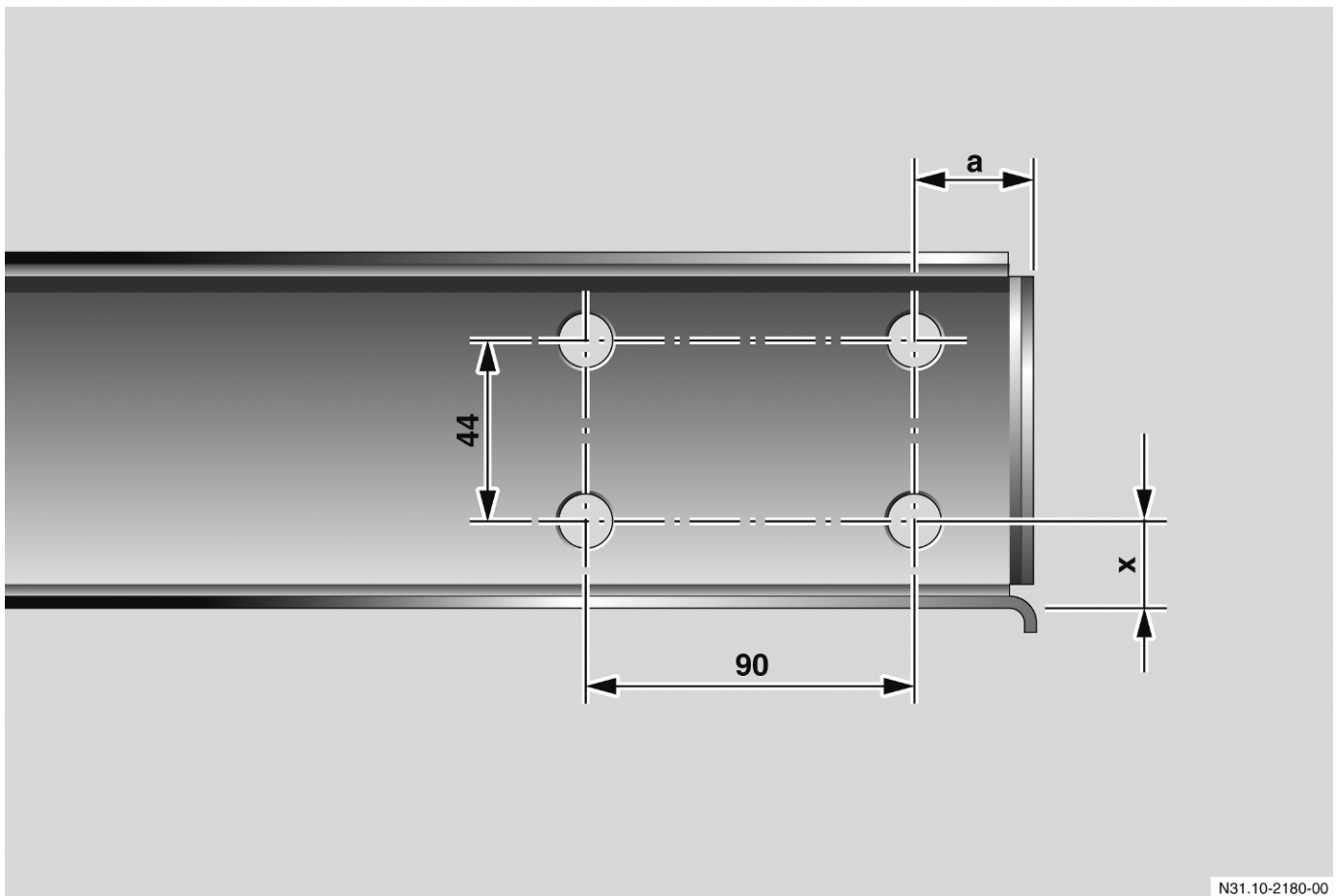
3500 Chassis Cab

N31.10-2180-00

Vehicle type	Wheelbase	Dim a	Dim x	Overhang
3500 Chassis Cab	144 in	27 mm / 1.1 in	34 mm / 1.3 in	1250 mm / 49.2 in
	170 in	27 mm / 1.1 in	34 mm / 1.3 in	1350 mm / 53.2 in

7.2.3. Chassis frame material

If the frame is extended, the material of the extension element must have the same quality and dimensions as the standard chassis frame.

Material quality:	
Material	Tensile Strength (N/mm ²) Yield Strength (N/mm ²)
H240LA (DIN EN 10268-1.0480)	350-450 260-340
S235JRG2 (DIN EN 10025-1.0038)	340-510 >235

7.2.4. Overhang extension

Modifications to the vehicle overhang are possible for the Chassis Cab and must always take the permissible axle loads and the minimum front axle load into account. On vehicles with a closed body (Cargo van or Passenger van), an overhang extension is not allowed.

- An additional cross member must be fitted if the frame extension exceeds 350mm [13.8in].
- Any additional frame cross members must have the same functionality as standard cross members.
- If the frame overhang is extended, the permissible trailer load specified in the vehicle registration document must be checked and, if necessary, be reduced or even omitted.
- The frame overhang must be reinforced accordingly.
- Make sure that you do not exceed the permissible axle loads.
- Ensure that you maintain the position of the center of gravity within the permissible limits.
- The minimum front axle load must be complied under in all load conditions.

You can obtain more information from SPRINTER ENGINEERING (→ chapter [2.7](#)).

Maximum overhang lengths

If you stay within the limits of the following overhang lengths and the maximum rear axle load, the original trailer load still applies and ESP operation is not affected.

Wheelbase I (in)	Max. overhang length x(mm) [in]
144	1850 [72]
170	2200 [85]

The vehicle overhang length is part of the total overhang referring to the rear axle, including the frame overhang extension and the body and attachments.

For information on the section dimensions of the longitudinal frame member see (→ chapter [7.2.1](#)).

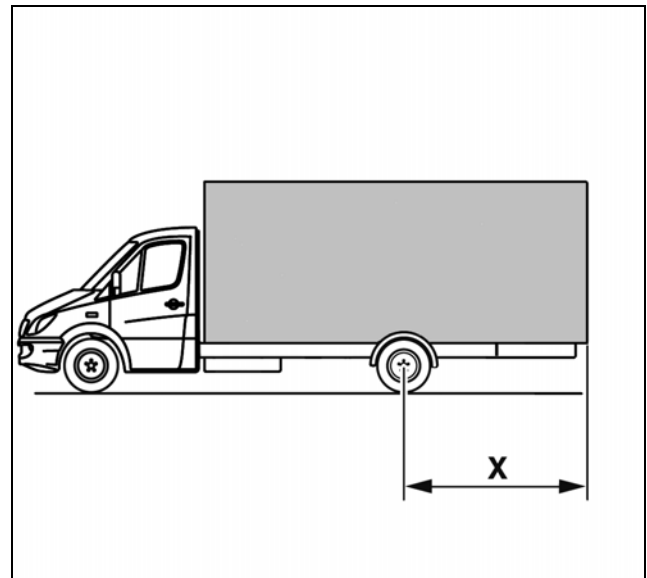

Maximum overhang lengths

X Maximum vehicle overhang

The illustration above depicts the implementation of a frame extension for an overhang extension. On completion of all work on the vehicle, you must comply with the specified corrosion protection measures (→ chapter [5.3](#)).

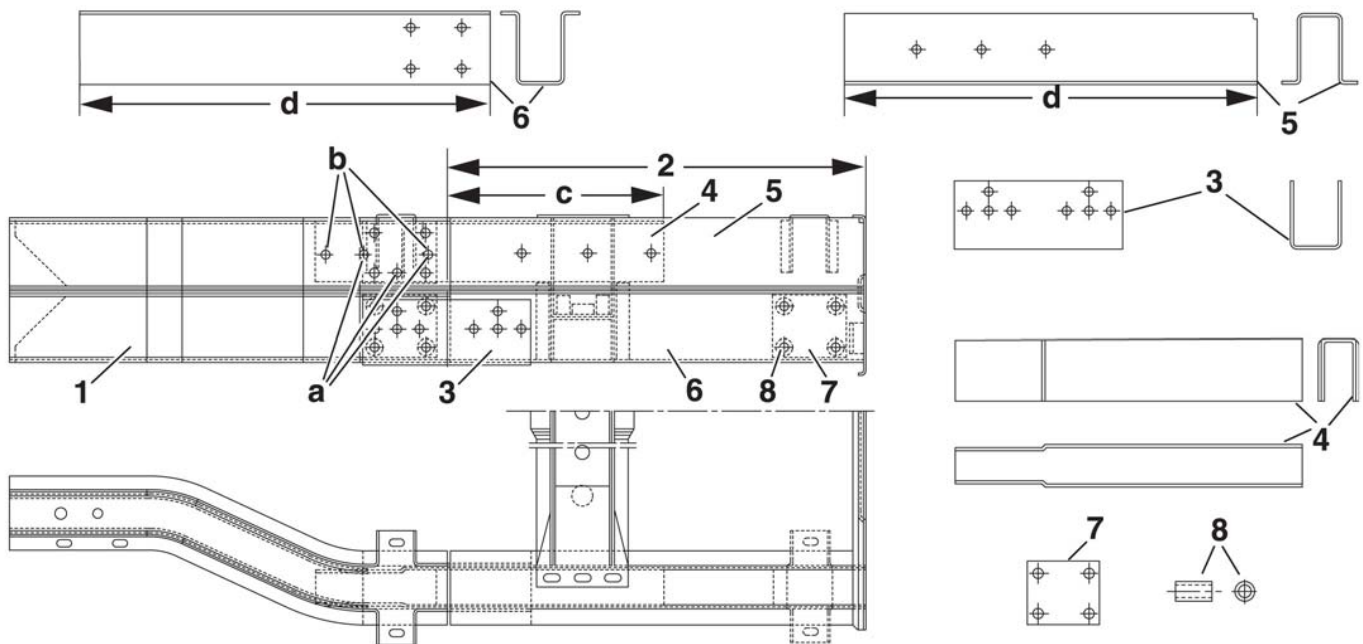
3500 SPRINTER Chassis Cab 11,030 GVWR frame extension with overhang extension

N31.20-2068-00

Frame extension with overhang extension

- 1 Longitudinal chassis frame member
- 2 Frame extension
- 3 Outer reinforcement
- 4 Internal reinforcement (wall thickness on 3500: 3mm)
- 5 Body mounting frame extension
- 6 Chassis frame extension (wall thickness on 3500: 3mm)
- 7 Reinforcement plate minimum 2 mm
- 8 Spacer bush, tube 24x4 M steel or ST 35 NBK
- a Bore holes, 3665mm [144 in] wheelbase
- b Bore holes, 4325mm [170 in] wheelbase
- c 350mm (3665mm [144 in] wheelbase)
300mm (4325mm [170 in] wheelbase)
- d Dimension defined by body builder

Comply with all applicable FMVSS / CMVSS guidelines and regulations

On completion of all work on the vehicle, you must comply with the specified corrosion protection measures (→ chapter 5.3).

Modifications to the cab roof

Warning

On no account should any subsequent modifications be made to the roof or the roof skin between the A-pillar and the B-pillar of the vehicle if the vehicle is equipped with window bags. Otherwise, the window bag may no longer be able to work correctly (e.g. window bag deployment is delayed or incomplete) which may lead in case of an accident to serious injury or death.

The “electric sliding sunroof”, (Option D27), is available from the factory as optional equipment (→ chapter [7.5](#)).

The roof load-bearing capacity is limited.

Roof arches or supporting parts may not be removed or modified.

You will find information on over cab attachments and wind deflectors in the “Attachments” section (→ chapter [7.6](#)).

Observe the permissible center of gravity and the permissible axle loads must be maintained.

Modifying the cab rear panel

If it is necessary to cut through the cab rear panel, it is possible to do this in connection with a continuous surrounding frame. The equivalent rigidity of the frame must be at least equal to the original rigidity. Partitions may be totally or partially removed. Refer also to the “Modifications to closed Cargo vans” section (→ chapter [8.4](#)).

Warning

Do not modify the roof lining or the roof skin between the A-pillar and the B-pillar if the vehicle is equipped with window bags. Otherwise, the window bag may no longer be able to work correctly (e.g. window bag deployment is delayed or incomplete) which may lead in case of an accident to serious injury or death.

7.2.5. Side wall, windows, doors and flaps

Sidewall

Body structure or reinforcement conversions which alter the sidewall structure of the Cargo Van or the Passenger Van need written approval from SPRINTER ENGINEERING. The body builder must meet all applicable FMVSS / CMVSS and warranty responsibility for those modifications. Do not modify the roof frame or structural components.

Upon completion of all work on the vehicle, body builders must comply with the specified corrosion protection measures (→chapter 5.3).

Retrofitting Windows

You must ensure the following when retrofitting side wall windows on Cargo vans:

- Use only approved glass manufacturer
- Use the interior structure as guidance.
- Do not cut into the interior structure.
- Use at least a 50mm (2") radius in the corners

Alternatively you can order option “Window Opening Without Glass” (Option PF3 fleet only).

When installing windows in existing openings, ensure that the windows are installed with a stable frame. If modifications need to be carried out to the supporting structure of the basic vehicle (pillars, reinforcements, attachment of roof arches) in order to retrofit windows (panorama glazing), the rigidity of the modified body must be equal to that of the basic vehicle.

More information about modifications to the sidewall can be found in the “fitting shelving/installations” section.

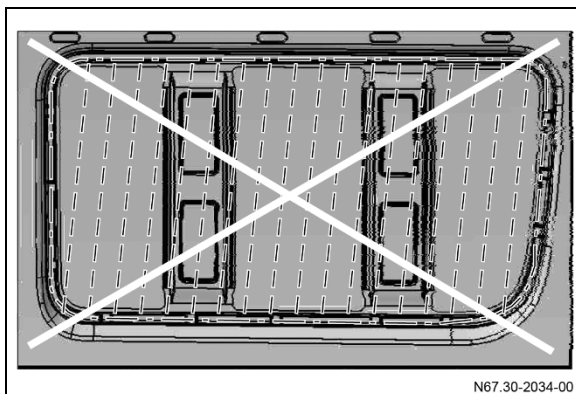

Doors and flaps

Body structure or reinforcement conversions to the supporting structure of the basic vehicle (frame cross members, pillars, reinforcements, attachment of roof arches) in order to retrofit doors, requires prior written approval from SPRINTER ENGINEERING.

The body builder must comply with all applicable FMVSS / CMVSS and warranty responsibility for those modifications. The rigidity of the modified body must be equal to that of the basic vehicle.

The trigger sensor of the occupant protection systems is located in the door body on vehicles with window or thorax bag.

Do not modify the door body (see illustration).

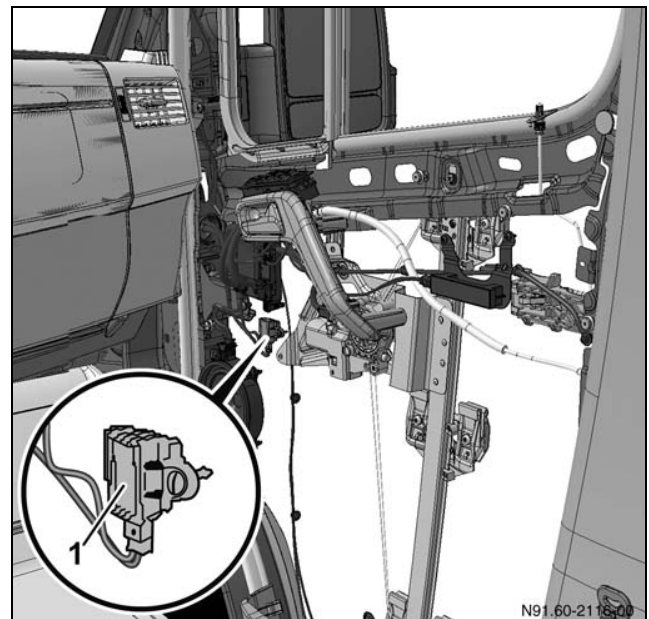

Door, showing sensor system

- 1 Pressure sensor (trigger sensor of the occupant protection systems)

Do not modify the rear door opening including the roof area.

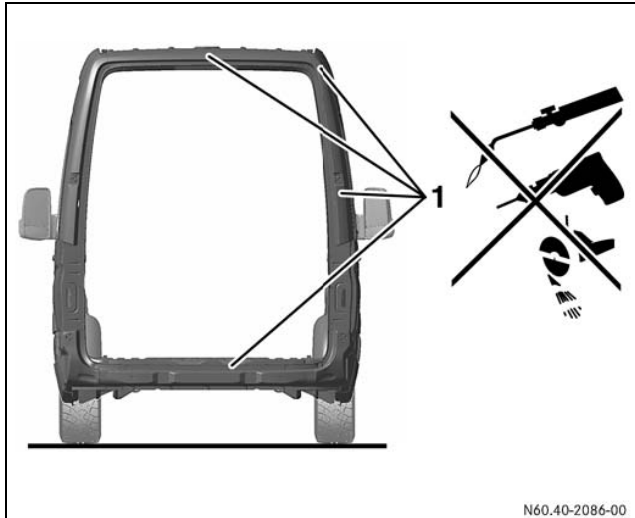

Rear door opening and roof area

- 1 Do not modify the above mentioned areas
- Seats in the passenger compartment or cabin must be directly accessible from the outside by a door or from the cab.
 - It must be possible to open locked doors quickly and easily from the inside.
 - The doors must open wide enough and the door entrances must be shaped in such a way as to enable persons to get in and out of the vehicle safely and comfortably.
 - The maximum permitted height of the bottom step above the road surface is 400mm [15.75 in].
 - Fittings must allow sufficient clearance to the interior door handles regardless of door position (trap guard).
 - Do not modify the central locking system or the immediate area around the door or in the area of the pillars or cross members.

Upon completion of all work on the vehicle, body builder must comply with the specified corrosion protection measures (→ chapter [5.3](#)).

7.2.6. End frame cross member

If special-purpose bodies are mounted, the end panel cross member can be ordered as an option. (Option Q18).

Upon completion of all work on the vehicle, body builder must comply with the specified corrosion protection measures (→ chapter [5.3](#)).

Comply with all applicable FMVSS/CMVSS guidelines and regulations.

7.2.7. Roof structure

Warning

Do not modify the roof lining or the roof skin between the A-pillar and the B-pillar if the vehicle is equipped with window bags and thorax bags. Otherwise, the window bag and thorax bag deployment may be delayed or incomplete, in case of an accident it may lead to serious injury or death. The roof load-bearing capacity is limited (see table).

Do not remove or modify roof bows or roof structure.

Maximum roof loads	
Low Roof Cargo Van kg / [lbs]	High Roof Cargo Van kg / [lbs]
300 / [660]	150 / [330]

Do not exceed the vehicle's maximum center of gravity limits.

7.2.8. Tire Clearance Chassis-Cab

Ensure that there is sufficient space between the tire and the mudguard or wheel wells with snow chains fitted and the suspension completely compressed (allowing for axle twist).

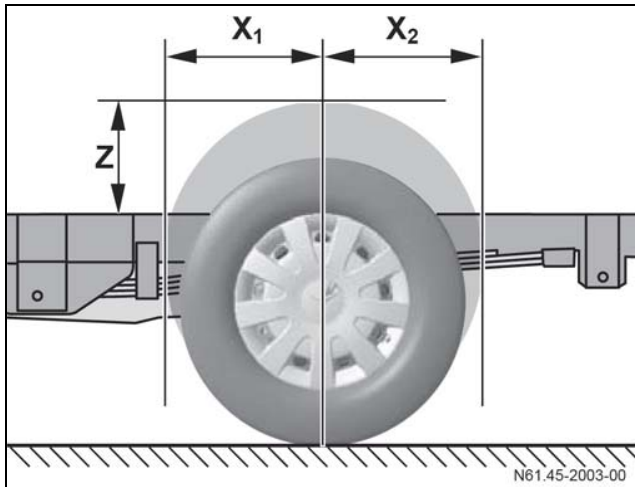

Tire clearance (side view)

- X₁ clearance from center of rear axle forward
- X₂ clearance from center of rear axle backward
- Z dimension from top of frame

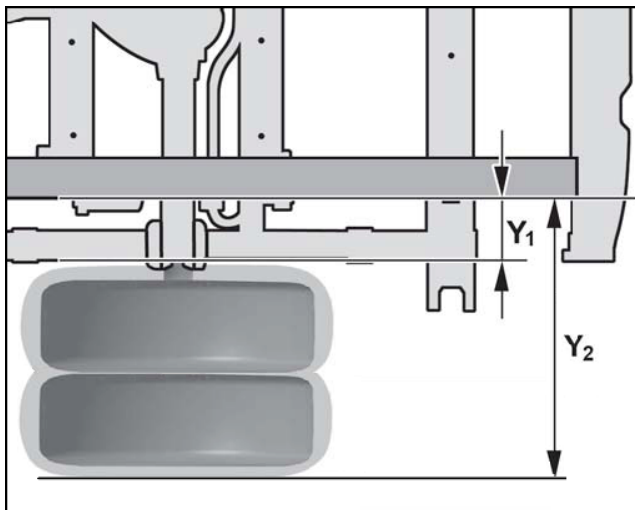

Tire clearance (top view)

- Y₁ clearance from frame to inner tire
- Y₂ clearance from frame to outside of outer tire

The minimum required wheel clearance is measured from the closest body member to the upper and lower chord of the longitudinal frame member on Chassis Cab vehicles including snow chain clearance on outer tire.

Rear Axle Chassis Cab 215/85 R16	Dimensions mm [in]	Dimension for snow chain mm [in]
X ₁	425 [16.75]	425 [16.75]
X ₂	425 [16.75]	425 [16.75]
Y ₁	110 [4.3]	110 [4.3]
Y ₂	640 [25.2]	640 [25.2]
Z	127 [5]	159 [6.25]

7.2.9. Wheel well Cargo-Van

Warning

Do not modify the wheel wells on Cargo and Passenger vans.

Warning

Do not install seats on the wheel wells. Otherwise, the vehicle could be damaged as a result (e.g. wheel wells and tires).

Upon completion of all work on the vehicle, body builder must comply with the specified corrosion protection measures (→ chapter 5.3).

Modifications to the width of the wheel wells are not permitted.

7.2.10. Cutting the cab roof and B-pillar roof arch

For partially integrated bodies, e.g. motor caravans or integral box bodies, the cab roof including B-pillar roof bow can be cut out in the indicated area (see illustration) where necessary.

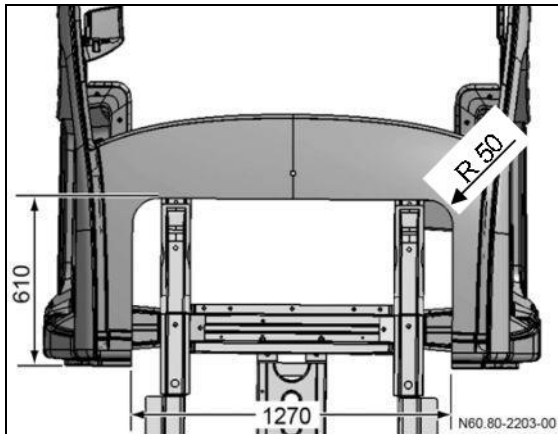

Permissible Roof Cut

width	610 mm [24 in]
length	1270 mm [50 in]
radius	50 mm [2 in]

Note:

When cutting the B-pillar roof bow, it is essential to ensure equivalent rigidity in one of the ways listed below.

For alternative methods of ensuring equivalent rigidity developed by the body manufacturer, a detailed evaluation by Sprinter Engineering & Compliance Support Team (SPRINTER ENGINEERING) is required; including but not limited to durability tests or FEA.

Equivalent rigidity when cutting B-pillar roof bow

Variant 1: Sandwich construction / wooden board

When the B-pillar roof bow is cut, the equivalent rigidity requirements can be met by means of a wooden board or sandwich construction bonded to the basic vehicle over its entire surface (e.g. with Sikaflex 221). The arched bow contour must be adapted to form a non-positive fit with the sandwich

construction or wooden board by means of an auxiliary construction.

Required bending resistance of sandwich construction / wooden board

y-axis	$EI_2 = 7 \times 10^8 \text{ N} / \text{mm}^2$ [$1.01 \times 10^{11} \text{ lb} / \text{in}^2$]
z-axis	$EI_1 = 2 \times 10^{11} \text{ N} / \text{mm}^2$ [$2.90 \times 10^{13} \text{ lb} / \text{in}^2$]

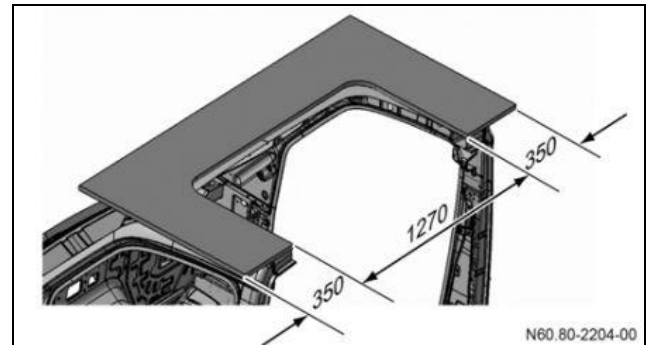

Simulating structure (sandwich construction / wooden board) bonded to cut roof structure over entire surface

width 1	350 mm [13 13/16 in]
width 2	1270 mm [50 in]

Material characteristics

Sandwich construction	Wooden board
Structure: 2.0 mm [1/8 in] GRP 26.0 mm [1 1/16 in] foam 2.0 mm [1/8 in] GRP	Structure: 20.0 mm [13/16 in] wood
$E_{\text{GRP}} = 12,000 \text{ N} / \text{mm}^2$ [$1.74 \times 10^6 \text{ lb} / \text{in}^2$]	$E_{\text{Wood}} = 3,000 \text{ N} / \text{mm}^2$ [$434,656 \text{ lb} / \text{in}^2$]
$E_{\text{Foam}} = 80 \text{ N} / \text{mm}^2$ [$11,590 \text{ lb} / \text{in}^2$]	

Variant 2: Welded structure under cab roof

When the B-pillar roof bow is cut, the equivalent rigidity requirements can be met by means of a welded structure installed in the basic vehicle under the cab roof.

Required bending resistance of welded structure

y-axis	$EI_2 = 8.35 \times 10^9 \text{ N / mm}^2$ [$1.21 \times 10^{12} \text{ lb / in}^2$]
z-axis	$EI_1 = 2.36 \times 10^{11} \text{ N / mm}^2$ [$3.42 \times 10^{13} \text{ lb / in}^2$]

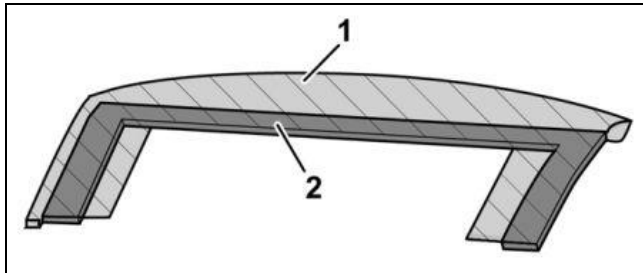

Welded structure

- 1 Roof paneling
- 2 Rectangular profile

Material characteristics of auxiliary frame

Material: at least DC0 1 or S235JRG2
Height = 20 mm [13/16 in]
Width = 100 mm [3 15/16 in]
Wall thickness = 1.5 mm [1/16 in]
$E = 210,000 \text{ N / mm}^2$ [$3.04 \times 10^7 \text{ lb / in}^2$]

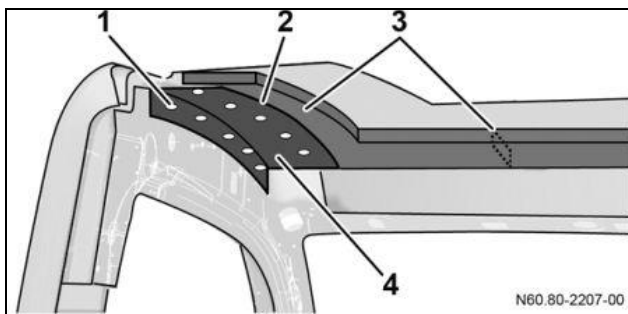

Welded structure

- 1 Plug welding
- 2 Overlap seam
- 3 Rectangular profile
- 4 End plate

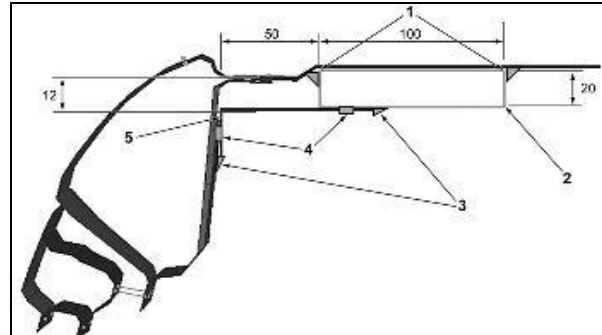

Cross section of welded structure

height 1	12 mm [1/2 in]
height 2	50 mm [2 in]
width 1	100 mm [3 15/16 in]
width 2	20 mm [13/16 in]

- 1 Fillet weld
- 2 Rectangular profile (2mm [1/8 in] wall thickness)
- 3 Overlap seam
- 4 Plug welding
- 5 End plate

7.3. Engine peripherals/drive train

Maintenance and repair of the vehicle must not be hindered by the body.

7.3.1. Fuel system

Do not modify the fuel system

- The installation of heat conducting components, or of components that restrict the installation space, is not permitted.
- Do not modify the fuel pump, fuel line length or fuel line routing. Modifications to these components could impair engine operation because these components are matched to each other.
- Modification and attachments (e.g. additional eyelets) are not permitted in the vicinity of the fuel filler neck.
- If bodies are mounted on a Chassis Cab, a fuel level sensor shield is necessary when the fuel level sensor is not protected by the body.

If bodies are mounted on a Chassis Cab, the fuel level sensor may have to be protected against any falling cargo, depending on the body type. Otherwise damage could occur, rendering the vehicle unserviceable.

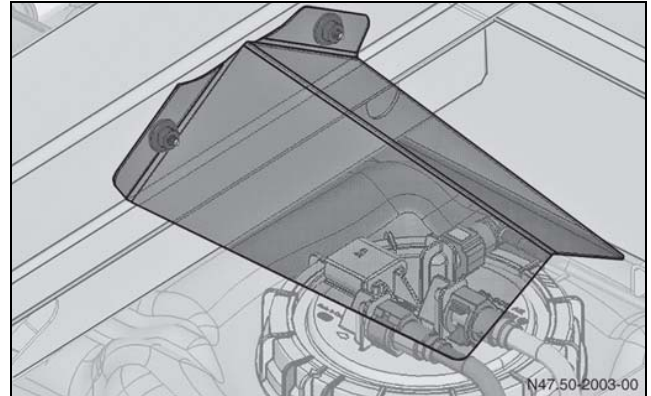

Fuel level sensor shield

The following must be observed if auxiliary Diesel powered generators are retrofitted:

- No sharp edges permitted
- Fuel lines must be secured
- Exhaust fumes must not be directed into the vehicle interior

For connections supplying fuel to the auxiliary power generator, contact SPRINTER ENGINEERING.

A fuel tap is standard equipment on Diesel engines. A small 'pig tail' is routed to the right side of the fuel tank. This fuel tap will prevent the fuel tank from running empty.

KL1 Auxiliary Diesel Fuel Tap (standard)

The fuel gauge sensor is fitted with an additional fuel connection to facilitate retrofitting of a fuel-powered auxiliary heater and/or generator. The fuel tank can be consumed down to approx.5 gal.

The picture shows a cap which can be removed. The connector piece is \varnothing 7.89 mm. Aftermarket quick connects have to be compatible with SAEJ2044 specified tube end forms.

For Quick Connector information, contact:
Cooper-Standard Automotive Fluid Systems
2110 Executive Hills Court
Auburn Hills, MI 48326 USA

Phone: 001-248-836-9400
Fax: 001-248-863-9116
www.cooperstandard.com

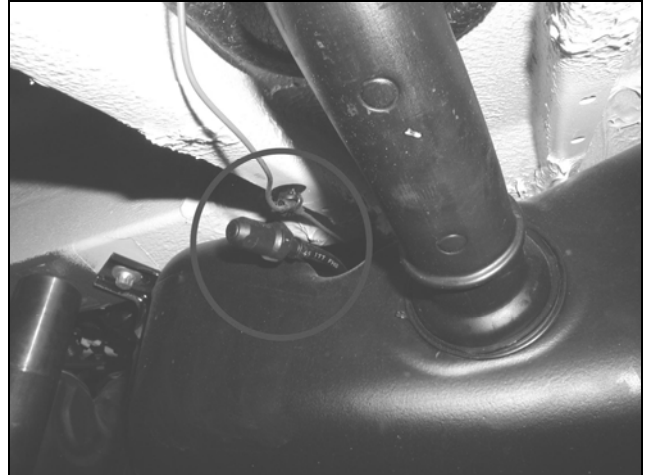

View from underneath without a fuel fired heater



Top view showing a fuel pump unit on a chassis cab

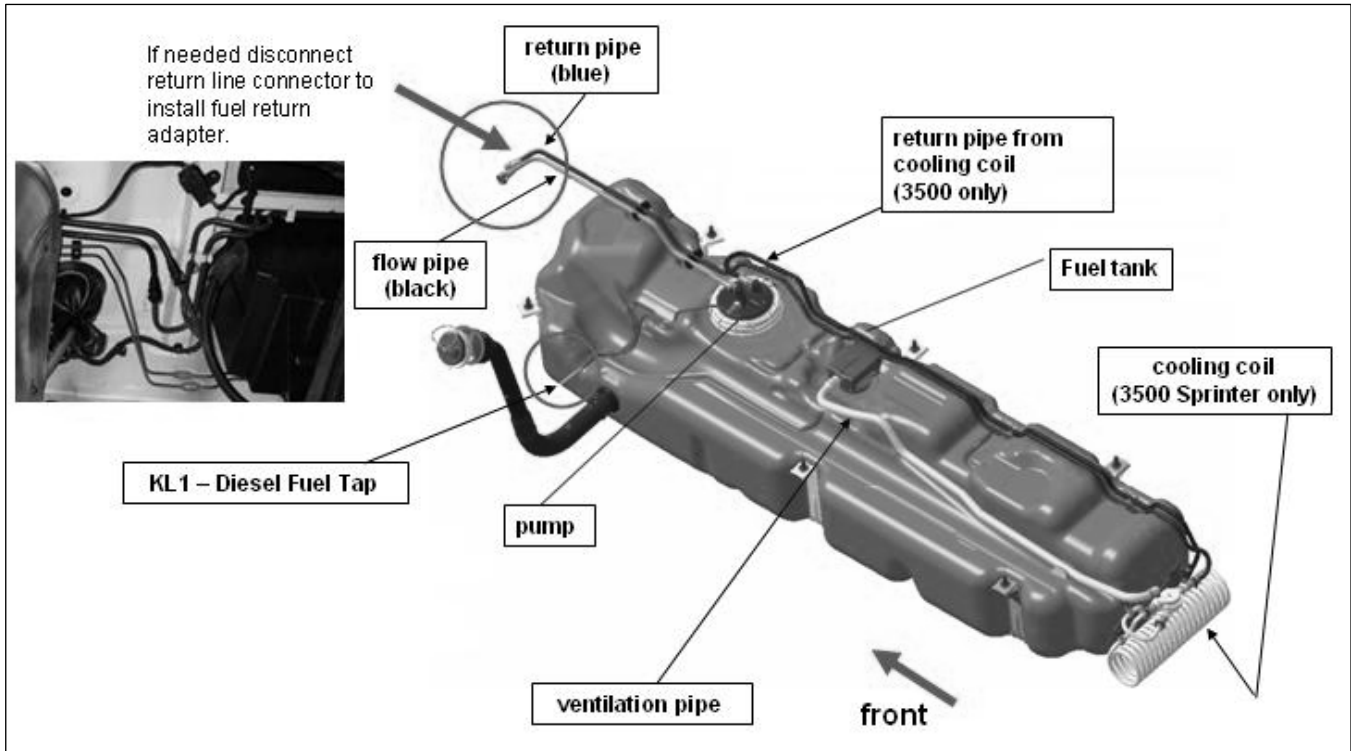

Diesel Fuel System 26.4 gal / 100 L

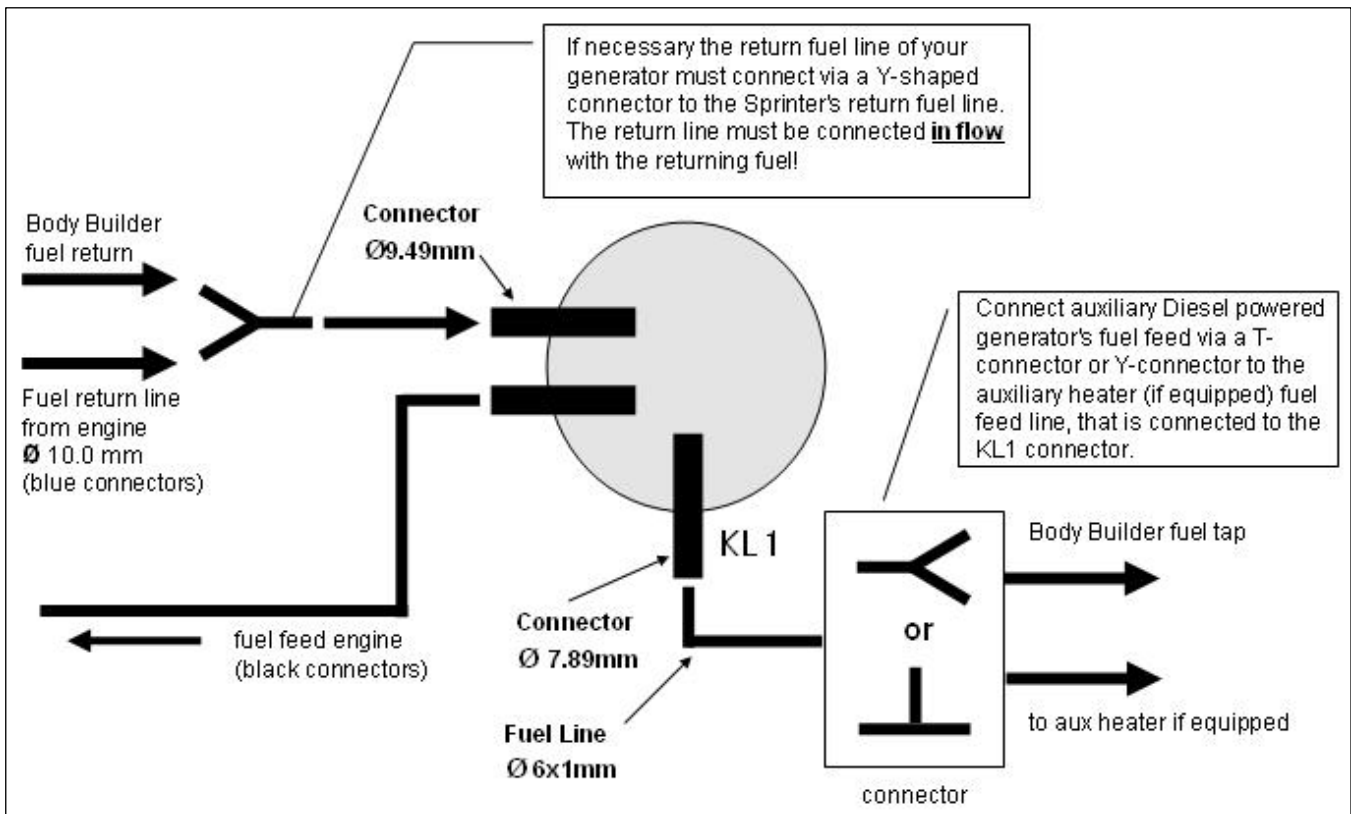

Fuel Tap Schematics

7.3.2. SCR system and DEF Tank location

In order to meet the strict 2010 EPA / CARB emission standards for Diesel powered engines, model year 2010 Mercedes-Benz & Freightliner Sprinters will require the use of a SCR (Selective Catalytic Reduction) system. The SCR system is an exhaust after treatment that significantly reduces (over 80%) NOx (Nitrogen Oxide).

Aside of sophisticated electronic controllers and sensors the SCR system requires a catalytic converter and a non-fuel reducing agent called DEF (Diesel Exhaust Fluid).

DEF is a mixture of Urea (33%) and water (67%). DEF is a non flammable, non-toxic, colorless, odorless water-soluble liquid.

DEF is stored in the vehicle in the DEF tank which features the SCR pump, temperature control, level sensors, etc.

DEF has a limited shelf life that is influenced by ambient temperature and humidity, as such DEF degradation as well as DEF level in the SCR tank are important factors to meet the emission standards.

- Due to chassis certification Sprinters under 10,000lbs GVWR cannot exceed the UVW and inertia weight of 7,400lbs
- Due to chassis certification Sprinters over 10,000lbs GVWR cannot exceed the inertia weight of 10,470lbs

See page 18 for label information. For all additional information consult the Owners Manual.

Warning

The SCR system is vital to comply with 2010 EPA / CARB emission certification. Do not modify or relocate individual components of the SCR system including but not limited to DEF tank, DEF lines etc. If DEF comes into contact with painted surfaces or aluminum surfaces, rinse the affected areas immediately with plenty of water.

If DEF fluid is pumped out of the tank, do not reuse. Its purity is no longer guaranteed and must be discarded.

Chassis Cab:

On Chassis Cabs the tank is located outside the frame and on the right hand side before the rear axle. The DEF filler neck is located directly on the tank. Weight increase: 155lbs



DEF Tank Location

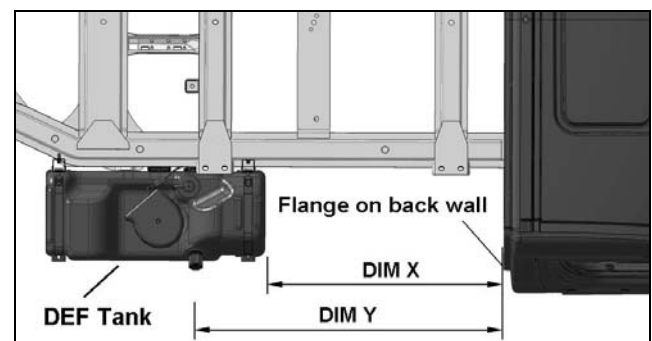

Top view DEF tank location (Chassis Cab)

Wheelbase (in) Chassis Cab	Dim X mm [in]	Dim Y mm [in]
144	887 [35]	1139 [45]
170	1547 [61]	1799 [70]

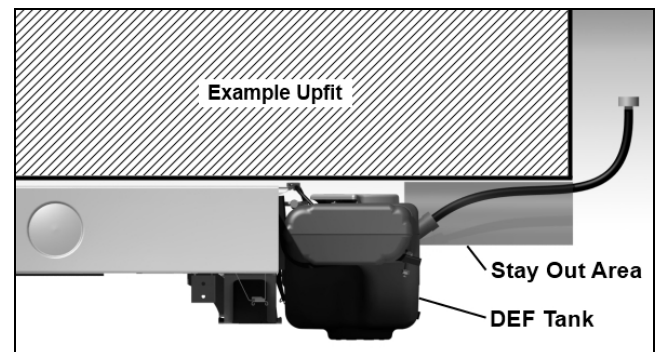

Rear view DEF tank stay out area 6'H x 6'W x 14'L

Easy access to refill the DEF tank must be ensured at all times.

For certification requirements the DEF tank must not be relocated.

Cargo and Passenger Van:

On Cargo Vans and Passenger Vans the tank is located outside the frame and under the right hand side sliding door. The DEF filler neck is located inside the engine compartment.

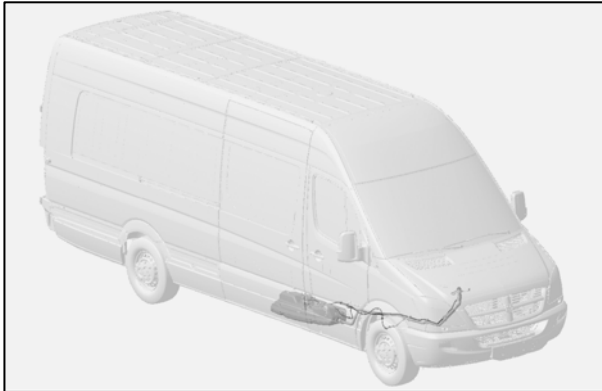

DEF Tank location

Weight increase: 144lbs

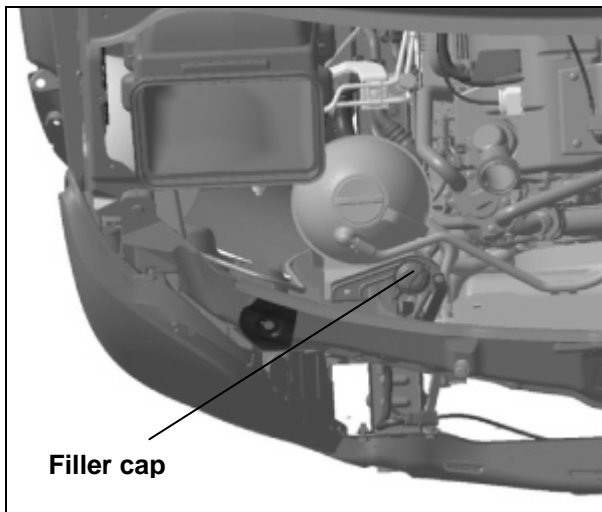

Filler cap left side under hood

Option KP2

Small DEF Tank 12L [3.2 gal] Capacity

This smaller tank is located on the front RH side under the headlamp behind the front bumper. The filler neck is the same as the 2010 Sprinter Cargo and Passenger Vans. The tank is bolted to the front RH longitudinal and front cross member at three attachment points.



Filler neck in the engine compartment



Small DEF tank location

7.3.3. Exhaust system

Do not modify exhaust system, except for the portion after the muffler. Comply with all applicable FMVSS/CMVSS guidelines and regulations.

Warning

Modifications to the exhaust system can only be made at 2 ft after the last muffler. Do not reduce the cross-sectional area of the exhaust pipe behind the muffler.

Under extreme loads, the temperature between the exhaust system (diesel particle filter, catalytic converter or main muffler) and the floor panel may rise above 80°C [180°F]. For this reason, heat shields or insulation must be fitted to the substructure to reduce heat radiation.

- Pipe bend, maximum 90°
- Avoid the use of additional pipe bends
- Bending radii >1.5 d

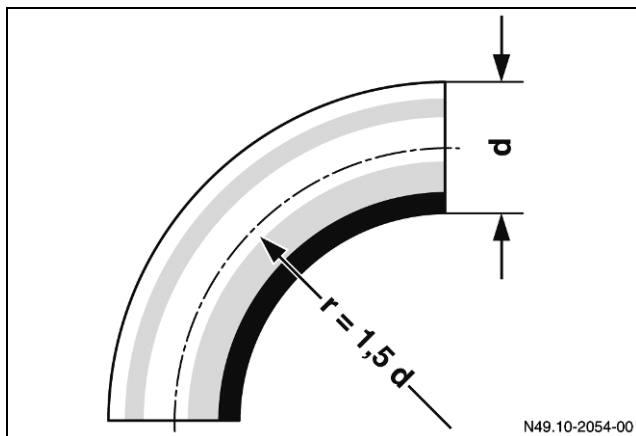

Example of a pipe bend design

Minimum distance to plastic lines, electrical cables and spare wheels:

- 200mm [8 in] for exhaust systems without shielding
- 80mm [3.5 in] with sheet metal shielding
- 40 mm [1.75 in] with sheet metal shielding and additional insulation

Upon completion of all work on the vehicle, body builder must comply with the specified corrosion protection measures (→ chapter 5.3).

Additional shielding is required

- Near control panels
- Near assemblies, attachments and equipment, unless they are made of heat-resistant material

Warning

Modifications to the exhaust system as far as the main muffler are not permitted. The lengths and routings, e.g. between the diesel particle filter and the main muffler, are optimized with regards to temperature characteristics. Modifications could lead to higher or extreme temperatures in the exhaust system and surrounding components (drive shafts, fuel tank, floor panel, etc.). The following exhaust system versions are available from the factory as optional equipment:

DPF (Diesel Particulate Filter) temperature during regeneration:

- Surface heat measured before DPF: 450-550 °C [842-1022 °F]
- Surface heat measured at DPF: 350 °C [662 °F]
- Surface heat measured after DPF: 350-500 °C [662-932 °F]

The regeneration cannot be triggered manually by the end user and is done automatically during normal operation.

If a manual regeneration is required please see an authorized Sprinter dealers.

7.3.4. Engine cooling system

It is not permissible to modify the cooling system (radiator, radiator grille, air ducts, coolant circuit, etc.) because a sufficient flow of cooling air must be guaranteed. The complete cross-section of the cooling air intake surfaces must remain unobstructed. This means:

- at least 171 in² for the front grille (radiator and condenser)
- at least 109 in² for the opening in the bumper (charge air cooler flow)

Do not affix warning signs, labels or decorative objects in the area in front of the radiator. Provision for additional cooling equipment for assemblies shall be made for when the vehicle is stationary and if a high continuous output is demanded.

7.3.5. Engine air intake

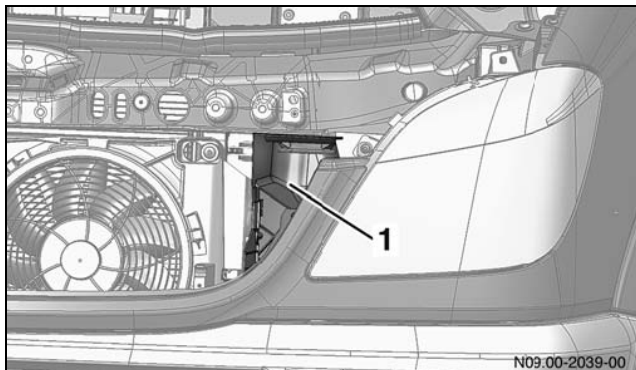

Engine air intake opening

1 Area of engine air intake

Do not modify the area of engine air intake (See illustration).

The air cleaner is secured by two rubber mounted brackets in the front module.

The securing design of the air cleaner must be retained in the event of any modification to the front module.

Warm air

The intake of warm air will lead to a loss of engine power. A bulkhead between the intake point and the engine compartment is therefore essential. The intake temperature should not exceed the outside temperature by more than 10 °C [50 °F].

Water

- Water running down the body, spray water or water from washing the vehicle must not flow directly past the intake points.
- Make sure that water cannot reach the intake points through any fresh-air inlets.

The flow rate at the intake points must not be increased by modifications to the opening of the intake points.

Dust / dirt

- Increased dust intake will lead to shorter maintenance intervals for the air cleaner.

7.3.6. Clearance for assemblies

Adequate clearances must be maintained in order to ensure the function and operating safety of assemblies (particularly of electrical lines, brake lines and fuel lines).

The dimensional data in the 2D drawings must be observed.

The distance between the cab and the body must be at least 50mm [2 inches].

7.3.7. Engine speed regulation

The engine must run at a specific speed in order to drive auxiliary equipment (e.g. pumps, compressors, etc.).

The “constant engine speed” optional extra, option M53 and MT4 (variable), is available for diesel engines only. Further information can be obtained from SPRINTER ENGINEERING.

The speed is freely adjustable across a speed range from 900 to 3,800 rpm, independently of the load.

Constant engine is not suitable for driving a generator if a constant frequency is required, as in the 220-V electricity supply network.

Retrofit solutions for regulating the engine speed are only possible with the ‘Programmable Special Module’ (PSM) optional equipment (apart from those retrofit solutions available as optional equipment (OPTION M53)).

7.4. Interior

7.4.1. General Information

The driver's and co-driver's airbag units, the window bags and thorax bags and the belt tensions are pyrotechnic components.

The purchase, transportation, storage, fitting, removal and disposal of potentially explosive substances may only be carried out by trained personnel and in accordance with the relevant safety regulations.

Modifications in the area of the dashboard and above the vehicle body waistline must comply with the head impact tests specified in CMVSS/FMVSS 201.

This applies in particular to the deployment areas of the airbags (wooden trim, additional fittings, mobile phone holders, bottle holders, etc.).

Paint or surface treatment is not permissible on the instrument panel, steering wheel impact absorber or air bag tear seams.

Warning

Do not paint or surface treatment on the instrument panel, steering wheel impact absorber or airbag tear seams. Otherwise, chemical reactions may occur on the treated surfaces. This could weaken or damage the materials, meaning that the restraint systems no longer operate properly.

See the illustrations of the airbag deployment areas for more information (→ chapter [7.4.2](#)).

You will find information on RV conversions in the RV section (→ chapter [8.11](#)).

The interior must be designated with soft edges and surfaces.

Fittings must be made of flame-resistant materials per FMVSS/CMVSS standards. Free access to the seats must be ensured. Avoid any protruding parts, edges or corners which could cause injury in the area of the seats.

Attachments with rigid connections to the front, side and rear of the vehicle at the height of possible accident zones could modify the characteristics of the vehicle's passive safety.

Warning

Do not modify airbag or the belt tensions system. Modifications to or work incorrectly carried out on a restraint system (seat belt and seat belt anchorages, belt tensions or airbag) or its wiring, could cause the restraint systems to stop functioning correctly, e.g. the airbags or belt tensions could be triggered inadvertently or could fail in accidents in which the deceleration force is sufficient to trigger the airbag and may lead to serious injury or death.

Warning

Reliable operation of the front airbag, window bag and thorax bag and belt tensions can no longer be guaranteed if modifications are made to the vehicle structure by the body builder, such as:

- Modifications to the seats and thus changes in the kinematics of the occupants in the event of an impact.
- Modifications to the frame front end
- Installation of parts in the vicinity of airbag inflation points or in airbag deployment areas
- Installation of non OEM seats
- Modifications to the A-pillar and B-pillar, the roof frame and its lining
- Modifications to the doors

This could otherwise result in serious injury or death.

7.4.2. Safety equipment

Airbag control unit and sensors

Do not modify the installation location, installation position and attachment of occupant-safety airbag control units and satellite sensors by comparison with the standard vehicle on vehicles equipped with window bags and thorax bags. Never secure other vehicle components to the airbag control unit, the satellite sensors or the securing points.

Warning

Never secure parts that create vibrations in the proximity of the airbag control unit or sensor installation locations and do not modify the floor structure in the proximity of the airbag control unit or the satellite sensors, otherwise operation of the front airbag, window bag and thorax bag and belt tensions may be jeopardized and there is consequently a risk of serious injury or death. The airbag control unit is located on the transmission tunnel under the center console.

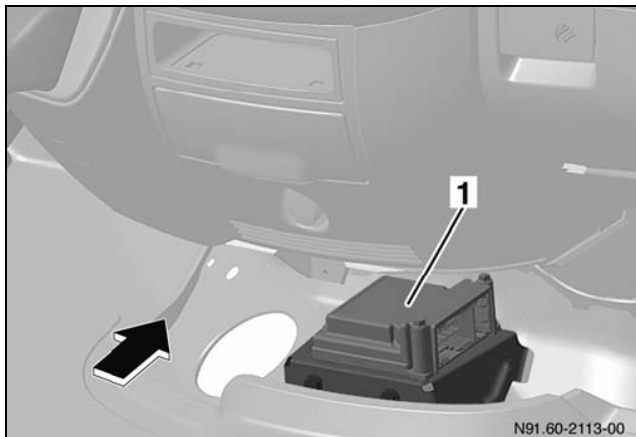

Location of airbag control unit

- 1 Airbag control unit
 Arrow Front of vehicle

The satellite sensors are located towards the bottom of the B-pillar behind the entrance trim in the driver's and co-driver's doorway compartment. The additional pressure sensors for vehicles equipped with window bags and/or thorax bags are fitted inside the doors.

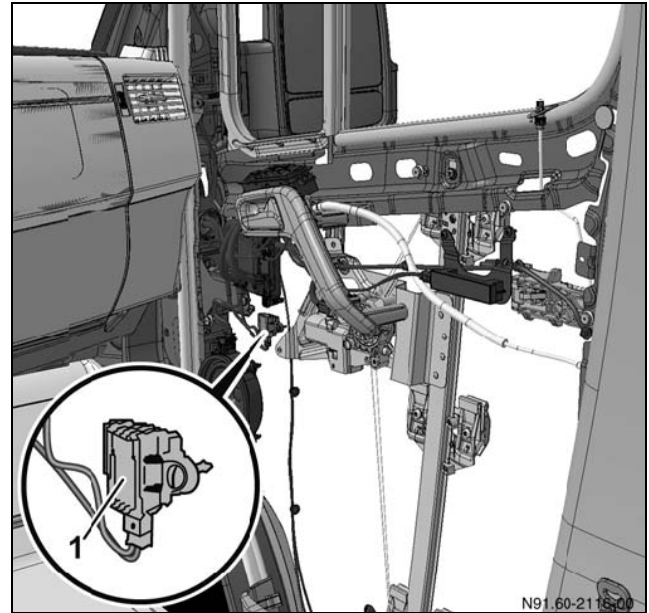

Front pressure sensor

- 1 Pressure sensor (trigger sensor of the occupant protection systems)

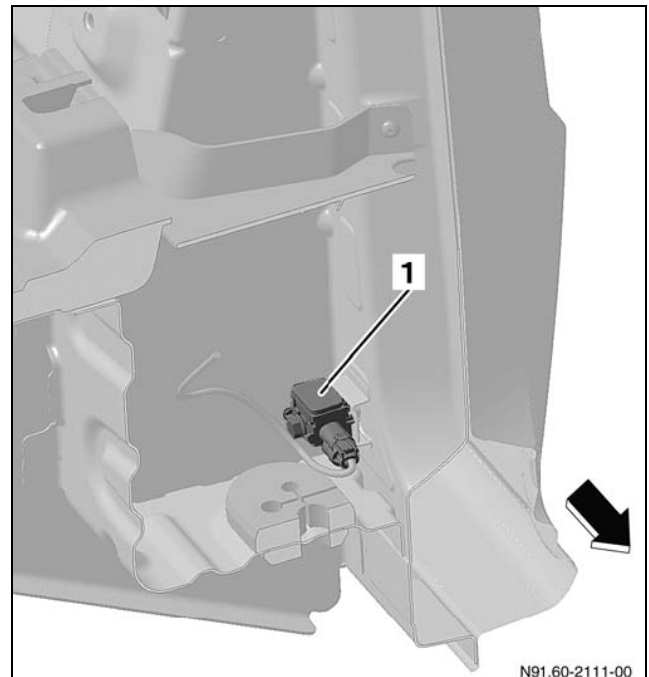

Sectional view of left-hand doorway area, B-pillar

- 1 Sensor (triggering sensor of the occupant protection systems)
 Arrow Front of vehicle

Seat belts and belt pretensioner

Warning

Never damage or soil parts relevant to safety such as seat belts or belt anchorages and pretensioner when work is carried out on the vehicle. Otherwise, these restraint systems may no longer function properly and may not provide adequate protection in the event of an accident leading to serious injury or death.

Use only the original seat belts otherwise the certification of the vehicle would be out of compliance. Seat belt anchorages must be tested in accordance with FMVSS/CMVSS standards.

All vehicles are equipped with pyrotechnic belt tensions in the retractors at the front seats. The retractors are located in the B-pillars. There is an additional retractor in the backrest of the bench seat on vehicles with two-seater co-driver's bench seat.

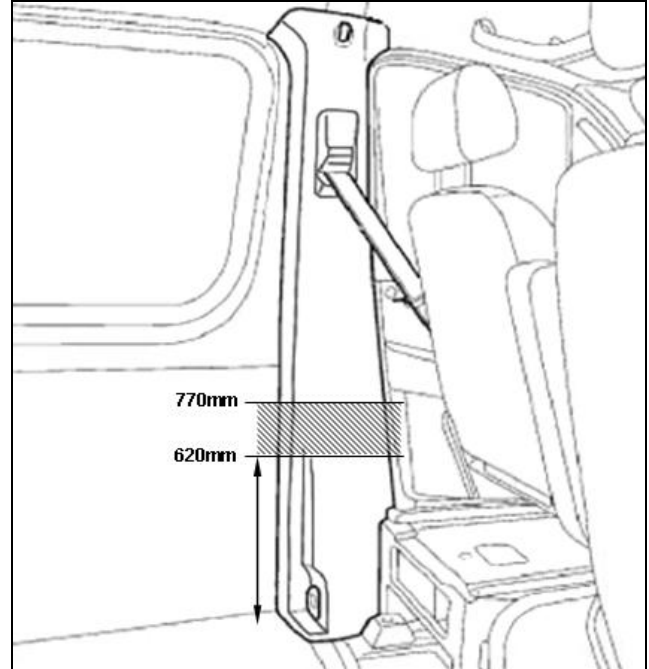

Location of seat belt retractor between 620-770mm [24.25 – 30.5 in] above floor.

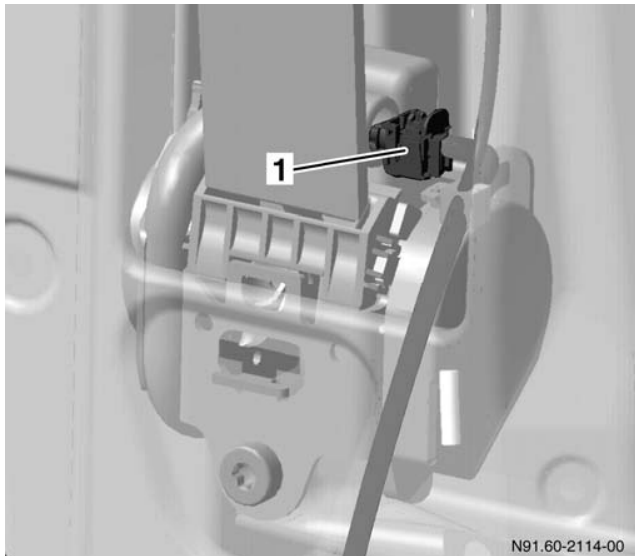

Retractor with pyrotechnic belt pretensioner

- 1 Connector

Warning

When installing aftermarket partition do not drill or attach any fasteners in the area around the seat belt retractor.

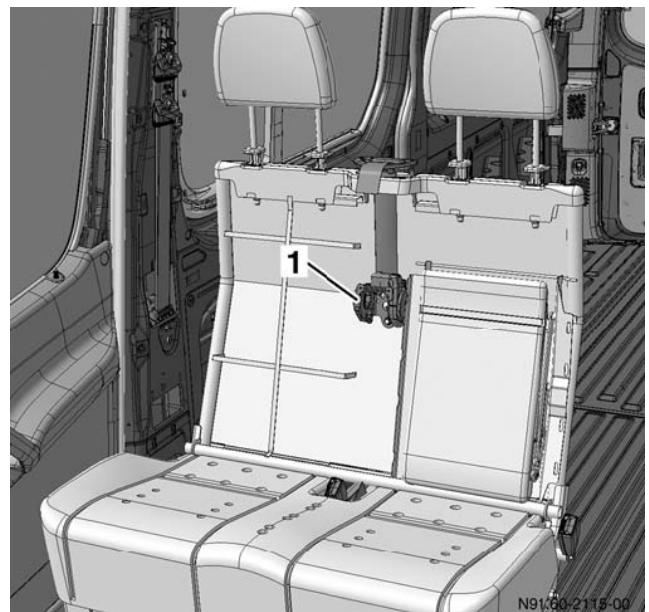

Co-driver's bench seat with retractors

- 1 Retractor

The legal requirements detailed in this section relate to current legislation. The relevant FMVSS/CMVSS legislation must be observed.

Warning

Never retrofit or replace front bench seats with individual seats. Otherwise, the restraint systems may no longer function properly and may not provide adequate protection in the event of an accident leading to serious injury or death.

Front airbag

All airbag units are labeled "Airbag"

- The driver's airbag unit is identified by the "Airbag" inscription on the steering wheel cover.
- The vehicle is equipped with a co-driver's airbag. This unit is also identified by the "Airbag" inscription.
- If the vehicle is equipped with window bags, they are identified by the "Airbag" inscription on the cover
- If the vehicle is equipped with thorax bags, these are identified by the "SRS Airbag" inscription on the backrest.

Another identification feature is the red "SRS" indicator lamp in the instrument cluster.

The following illustrations show the location and deployment areas of the driver's and co-driver's airbags as well as that of window bag and thorax bag. The deployment areas shown are greater than the actual volume of the airbag because space is required for airbag rebound as it deploys.

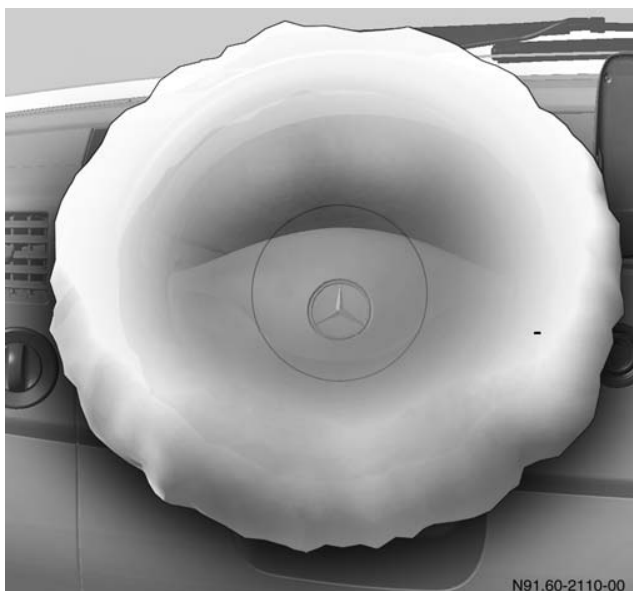

Deployment area of driver's airbag



Deployment area of co-driver's airbag

Side-impact airbags

Do not modify the B-pillar, door bodies, trim and seat upholstery.

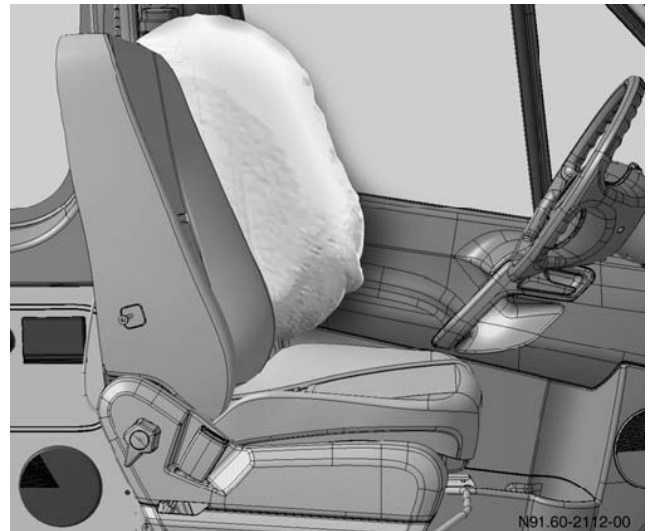

Deployment area of left-hand side thorax bag

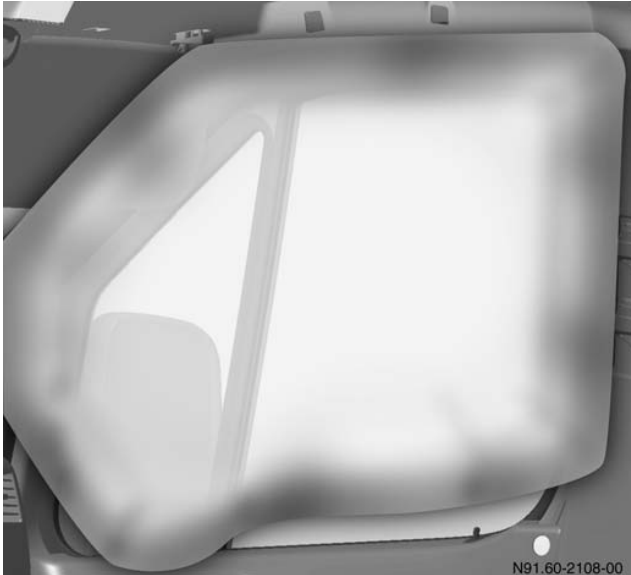

Deployment area of right-hand window bag

Warning

Work on the A-pillar may cause damage to the window bag, which could cause the window bag to no longer function properly.

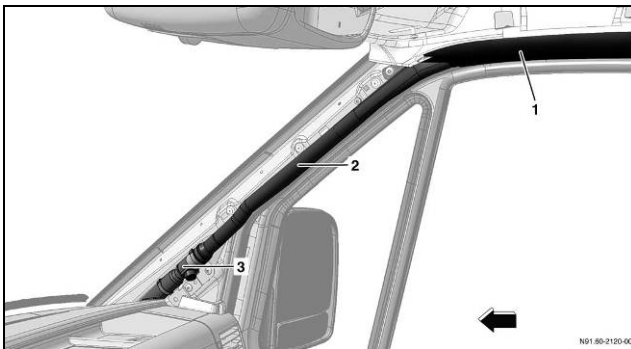

Window bag installation location

- 1 Cover
- 2 Window bag in protective sleeve
- 3 Gas generator in window bag
- Arrow Front of vehicle

Working with airbag and belt pretensioner units

Warning

Removed airbag units must always be stored in such a way that the upholstered side faces upwards. If the upholstered side faces downwards, the airbag unit will be catapulted through the air if it is triggered accidentally and may lead to serious injury or death. The airbag units fitted to the SPRINTER include the driver's and co-driver's airbags as well as the optional window bag and thorax bag.

- Work involving removed airbag and belt pretensioner units, and testing and installation work, may only be carried out by trained personnel.
- The airbag and belt pretensioner units and the airbag control unit must be fitted without delay and immediately on removal from storage. The vehicle battery must have been disconnected, the negative pole or negative terminal covered and the test coupling/connection disconnected.
- If work is interrupted, the air bag and belt pretensioner units must be locked away again.
- The airbag and belt pretensioner units may not be treated with grease, cleaning agents or other similar products.
- The airbag and belt pretensioner units may not be exposed to temperatures above 100°C [212°F] even for a short period of time.

Airbags, belt pretensioner units, the sensors and control units, must be replaced if they are dropped from a height of more than 0.5 m [20 inches]. Airbag and belt pretensioner units may only be subjected to electrical tests using the specified testers when the airbag and pretensioner units have been fitted. We recommend that tests be carried out at an authorized SPRINTER Service Center.

Disconnect the main battery by disconnecting the negative terminal covered and the test coupling / connection disconnected before the airbag and belt pretensioner unit are removed.

Transporting and storing airbag units and belt pretensioner units

Internal transport should always be carried out using the spare parts packaging and utilizing the vehicle luggage compartment or load compartment.

Never transport airbag in the passenger compartment. The airbag units fitted to the SPRINTER include the driver's and co-driver's airbags as well as the optional window bag and thorax bag.

Warning

Airbag and belt pretensioner units must be disposed of by personnel who have undergone special training for this task. Accident prevention regulations must be observed otherwise it may lead to serious injury or death.

You will find information on retrofitting seats in the "Implementation of bodies" section.

Warning

On no account may seats be mounted on the wheel wells. Otherwise, in an accident the seats may become loose and may lead to serious injury or death.

7.4.3. B-Pillar cover removal & reinstallation

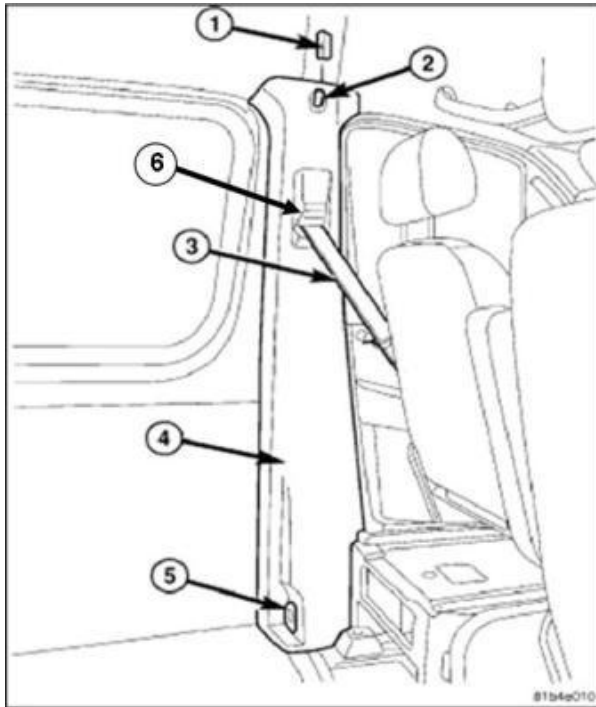

1. Trim coat hook
2. Coat hook
3. Seat belt
4. Trim B-pillar
5. Cargo tie down
6. Seat belt height adjustment mechanism

Removal of B-Pillar Cover

1. Pull coat hook trim 1 upwards and remove coat hook 2.
2. Remove the cargo tie down 5 or cover.
3. Remove the seat belt 3 from the seat (if needed).
4. Remove the assist handle covers and remove the screws (optional equipment). Remove the assist handle from the passenger side B-pillar.
5. Pull the trim 4 on the B-pillar out of clip connections starting at top and remove downward.
6. Remove the seat belt 3 from the trim 4 (if needed).

Reinstallation of B-Pillar Cover

1. Pull the seat belt through the B-pillar cover.
2. **IMPORTANT:** Slide adjustment part of B-pillar cover to top position before reinstallation. Insure that the seat belt height adjustment fits correctly into guide. Make sure that the door rubber seals are seated correctly.

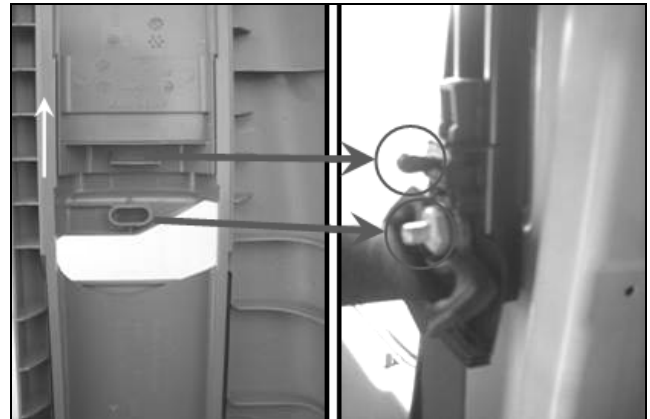

Correct Alignment of B-Pillar Cover

3. Install the trim onto B-pillar and seat clips starting from bottom moving upwards. Install the seat belt to the seat. Install the cargo tie down or cover. Torque cargo tie down with 18 Nm [13.3 ft-lbs]. Install the coat hook and seat trim fully. Bolt the end fitting to seat. Torque belt end with 37 Nm [27.3 ft-lbs].
4. Check seat belt and its height adjustment for proper functionality otherwise check step 2 again.

Note:

If entire seat was removed torque seat bolts (4x) with 37 Nm [27.3 ft-lbs].

Dampening Device on Height Adjustment (Partition Wall Only)

Sprinter Cargo Vans with partition walls (D50, D51, D53, D62 and D64) come with a 1 dampening device (left and right side) on top of the height adjustment mechanism. Make sure dampening device is fitted properly into height adjustment before reassembly.

Note:

Dampening devices are not used on Sprinter Chassis Cab and Passenger Vans.

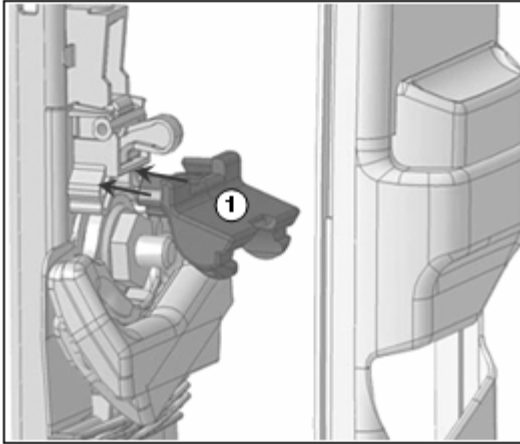

- 1 Carpet (bonded underside)
- 2 Wooden floor (12mm - .5in plywood)
- 3 Heavy-duty insulation material (8 to 10kg/m² / 1.6 to 2lbs/ft²)
- 4 Supporting construction

Roof and side panels

Rock wool, glass wool, fibrous web or soft, open pore PE or PU – based foam are effective insulation materials. The inside must be covered with a sound-transmitting material (perforated card, plastic, fabric cover).

Dampening Device
Interior

B-Pillar Cover
Exterior

7.4.4. Reducing noise in the vehicle interior

To reduce the noise level in the vehicle interior, flame retardant noise insulating materials may be installed.

Floor area

A structure as shown in the illustration is recommended for insulation and soundproofing. An additional covering with heavy-duty insulating foil may be provided in the area of the wheel wells. Insulating foils, e.g. bituminous felt, have limited temperature resistance. They should therefore not be installed in the immediate vicinity of the engine or exhaust system.

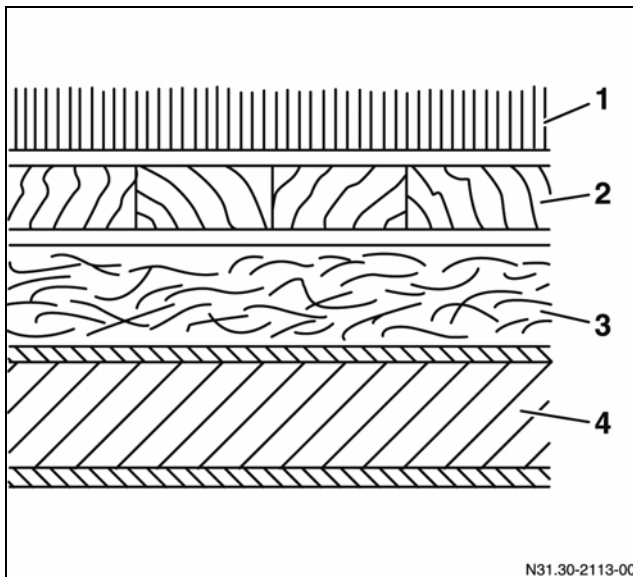

N31.30-2113-00

Warning

Do not modify the roof lining or the roof skin between the A-pillar and the B-pillar if the vehicle is equipped with window bags. Otherwise, the window bag may no longer work correctly (e.g. window bag deployment is delayed or incomplete). In case of an accident it may lead to severe injury or death.

Seals

Openings, gaps and slots between the engine compartment, the underside of the vehicle, the front bulkhead and the vehicle interior must be carefully sealed with anti-corrosion protection or a permanently elastic material following treatment. Air vents must not be fitted in the immediate vicinity of sources of noise or exhaust fumes.

In addition, manufacturers or suppliers of sound proofing materials should be consulted.

They will be able to provide you with suggestions on how to design optimum noise insulation for your particular body.

7.4.5. Ventilation

The passenger compartment and the driver's seat must have adequate ventilation with provision for air to enter and exit.

The windscreen and side window demisting function must remain operational, especially if the driver's area forms part of the passenger compartment or if the layout and design of the interior does not correspond to that of the standard equipment.

New vehicles can be supplied from the factory with the optional equipment "Controlled air conditioning/in addition in rear compartment" under options H08.

When retrofitting assemblies, please refer to the "additional Equipment" section (→ chapter [7.5](#)).

7.5. Additional equipment

If additional equipment is fitted, factory-fitted power take-offs must be used.

7.5.1. Retrofitting an air-conditioning system

All electrical equipment fitted must be tested in accordance with FMVSS/CMVSS standards.

When retrofitting air-conditioning systems, we recommend the “Rear-compartment air-conditioning system” option H08 which can be obtained from the factory as optional equipment.

The requirements of the equipment manufacturer must be observed if you intend to retrofit any other air-conditioning system. The following points must be observed to ensure compatibility with the basic vehicle:

- Do not tie in the OEM A/C system
- On no account should the installation of an air-conditioning system impair vehicle parts or their function.
- The battery must have sufficient capacity and the alternator must generate sufficient power.
- Additional fuse protections for the air-conditioning power circuit
- Air-conditioning compressors must be attached using the equipment carrier provided.
- The additional equipment for driving air-conditioning compressors is available from the factory as optional equipment under Option N63 (maximum output 8kW).
Ensure that wires and electrical lines (→ chapter [7.3.5](#)) are routed correctly.
- There should be no impairment of the accessibility or easy maintenance of installed equipment.
- The operating instructions and the maintenance manual for the additional equipment must be supplied on handing over the vehicle.
There should be no impairment of the required engine air supply and cooling
(→ chapter [7.3.3](#))

7.5.2. Auxiliary heating

The floor of the vehicle must be air-tight if exhaust gases are routed out under the vehicle. Openings in the vehicle floor provided for control elements must be sealed with rubber sleeves. The following auxiliary heating system is available from the factory as optional equipment:

Description	Option
auxiliary heater front	H12
auxiliary heater rear	H13

More information is contained in the Special Equipment Book from your authorized SPRINTER dealer.

7.5.3. Power take-offs

General

Engine power take-off at front of engine only.

Power take-off versions available from the factory. These power take-offs can be obtained from the factory as optional equipment.

The following codes are available for power take-offs:

Code N62	Additional alternator
Code N63	Refrigerant compressor

These power take-offs can be obtained from the factory as optional equipment.

The maximum power output is:

Code N62	8.5 kW (11.4 hp)
Code N63	8.0 kW (10.7 hp)

The additional pulley is located in the second belt plane (belt width 12.7mm, effective diameter 128.2mm).

Code N62	Poly-V-belt pulley, 50 mm external diameter, 6 grooves
Code N63	Poly-V-belt pulley, 120 mm external diameter, 6 grooves.

We recommend using the following genuine DG SPRINTER belts

For option:	MB part #
Code N62	A001 993 47 96
Code N63	A001 993 37 96

Additional equipment can be mounted on an equipment carrier fixed to the engine.

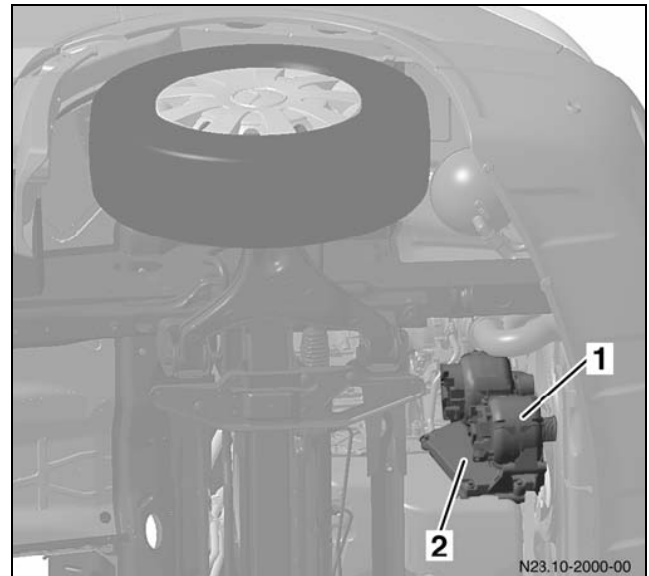

Additional equipment on engine-resident equipment carriers

- 1 Additional equipment
- 2 Equipment carrier

Maximum weight of additional equipment

Code N62	7.3 kg (16.1 lbs)
Code N63	6.5 kg (14.3 lbs)

7.6. Attachments

Make sure that you adhere to the permissible axle loads in all cases.

Attachments must not impair the function of vehicle parts.

Comply with all applicable FMVSS/CMVSS requirements. Do not attach a winch to the front section of the frame.

Winches behind the cab

If winches are attached behind the cab, they must be mounted on a mounting frame of sufficient size and strength.

7.6.1. Wind deflectors

Wind deflectors may only be fitted onto the cab roof by applying high-strength adhesive to the whole area around the lateral roof frame, the front roof frame and the first roof arch (level with the B-pillar). The load applied by air resistance and contact pressure must be taken into consideration. The deflectors must only be fitted in such a way that the basic vehicle is not damaged.

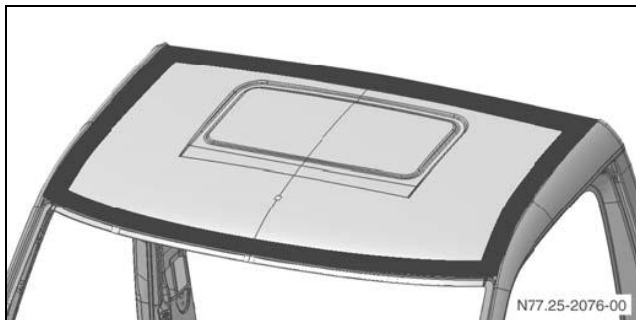

Adhesive for fitting wind deflectors should be applied in the area shown

No further holes should be drilled in the cab roof for fixing additional attachments.

If other roof attachments are fitted, please consult with SPRINTER ENGINEERING.

7.6.2. Attachment above cab

- The permissible center of gravity location and the front axle load must be observed (→ chapter 4).
- The attachment to the roof must be designed as described in the “Bodyshell” section (panel van roof) (→ chapter 7.2).

7.6.3. Roof racks

SPRINTER – Cargo vans and Passenger vans:

- Make sure that the load is distributed evenly across the entire roof area
- We recommend the use of an anti-roll bar at the front axle
- Support feet must be spaced at regular intervals. 110 lbs per pair of feet and strut is recommended as a basic rule.
- With shorter roof racks, the load must be reduced proportionally.

Roof rack limiting values (laden)

Maximum roof loads	
Cargo Van kg / [lbs]	High Roof Cargo Van kg / [lbs]
300 / 660	150 / 330

To make it possible to fit roof racks, the SPRINTER must be equipped with C-rails (Option D13, for Cargo Vans only). C-rails can be retrofitted.

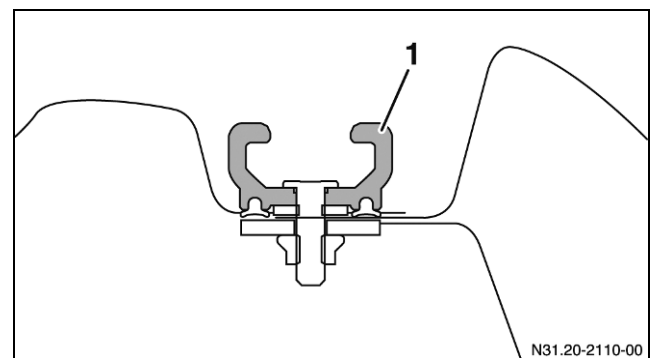

Roof rack mounting

- 1 C-rail (roof rack)

7.6.4. Fitted shelving/installations

Fitted shelving must:

- be sufficient strong and self-supporting
- rest on the cross and longitudinal members of the vehicle floor
- distribute forces evenly
- it is preferable to make attachments at the points of the load rails and lashing eyelets.

Do not transfer loads only to the vehicle side walls. For a favorable force transfer, we recommend the use of load rails available as optional equipment or their entire contact area in the body shell:

	Max rated tensile force
Code VC4 on roof frame	150 daN [33 lbf]
Code V42 on waist rail	250 daN [56 lbf]



Load rails in the panel van

1 Load rails
Arrow Front of vehicle

For further information about the side wall
(→ chapter [7.2.5](#))

Fittings for fitted shelving

Code ZE6 “Shelving Prep” is available from the factory to facilitate the retrofitting of shelves. The package includes angles attached to the roof arches and body support brackets mounted on the floor.

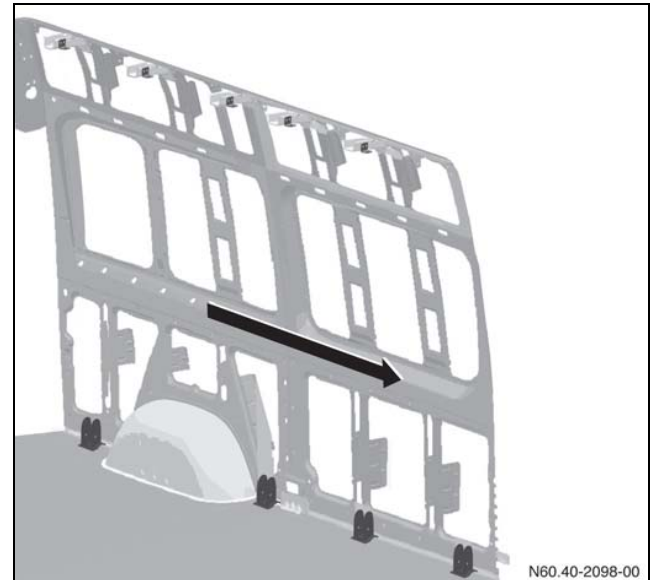

ZE6 package contents in shaded areas

Arrow front of vehicle

The following must be observed when using the shelf fittings:

- Shelves must not be wider than 450 mm [17.5inch]
- The max load-bearing capacity is 80 kg/m [50 lbs/ft]
- The shelf support must be made of steel with a minimum cross section of 60x40x3mm [2.25"x1.5"x1/8"] (length x width x thickness).
- The shelf supports are bolted to the floor bracket.

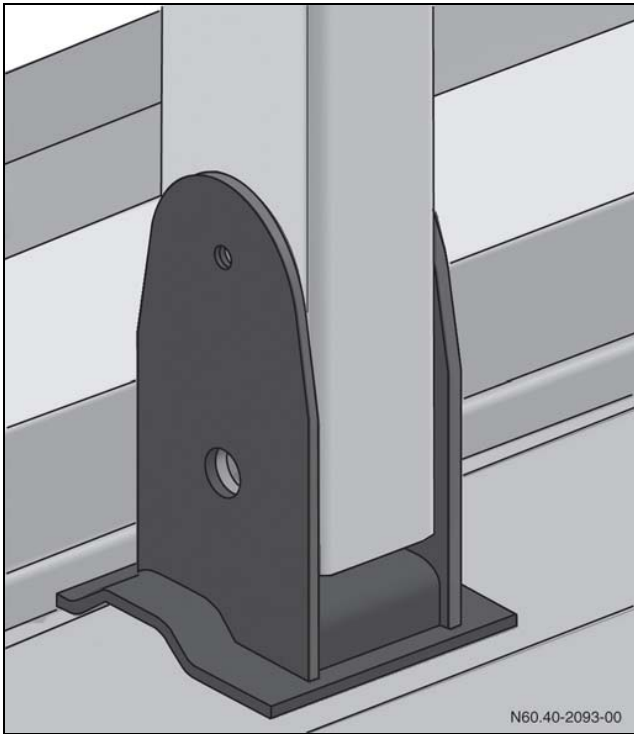

Bolting the support to the floor bracket

- To fix the wooden floor, 2 angles per support must be mounted at the bolt connection between the support and the bracket (contact surface per angle at least 1,200mm² [186 in²], dimension 60mm x 20mm [2.5in x 0.8in])
- A steel tube with a rectangular profile measuring 60mm x 40mm x 3mm [2.25"x1.5"x1/8"] is bolted onto the brackets on the roof arches. The shelf supports are bolted to the rectangular profile at the top.

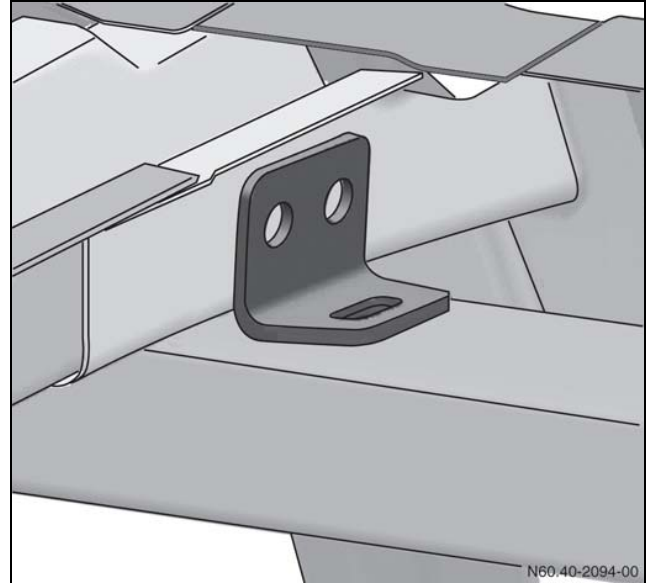

Bolting the longitudinal tube to the roof arch

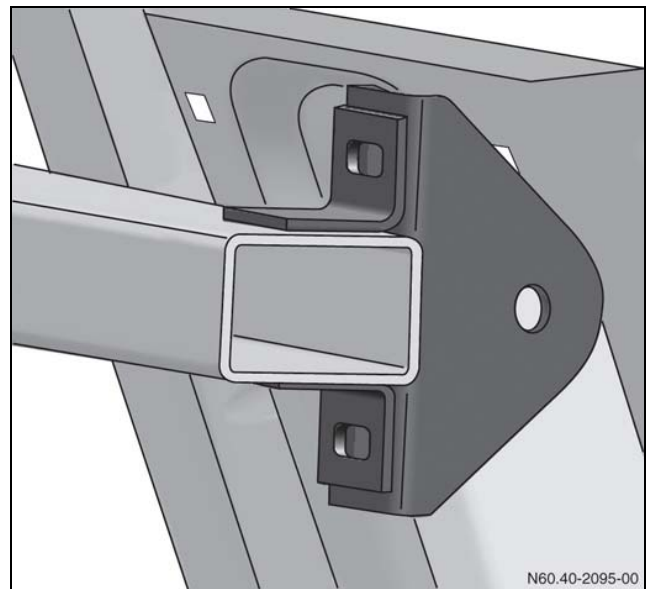

Connecting the longitudinal tube to the support

- The longitudinal tube must not be connected with the partition or the rear door.

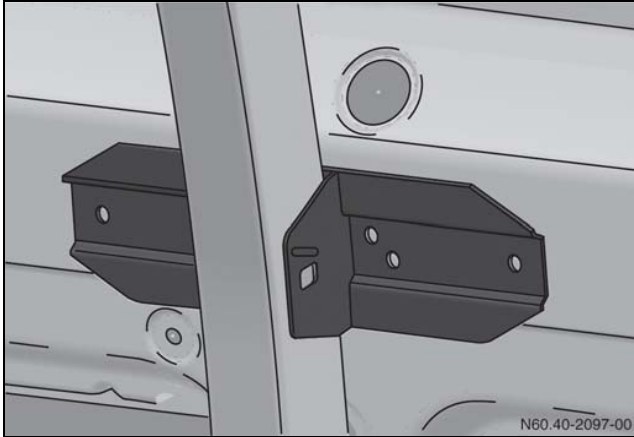

Suggestion for bracket on waist rail

In addition to fixing the self support to the floor and to the roof arches, it is necessary to fix them to the waist rail using a bracket. The connection must be made by bonding and riveting. A minimum bonding surface of 7,000 mm² [10.0 in²] is required.

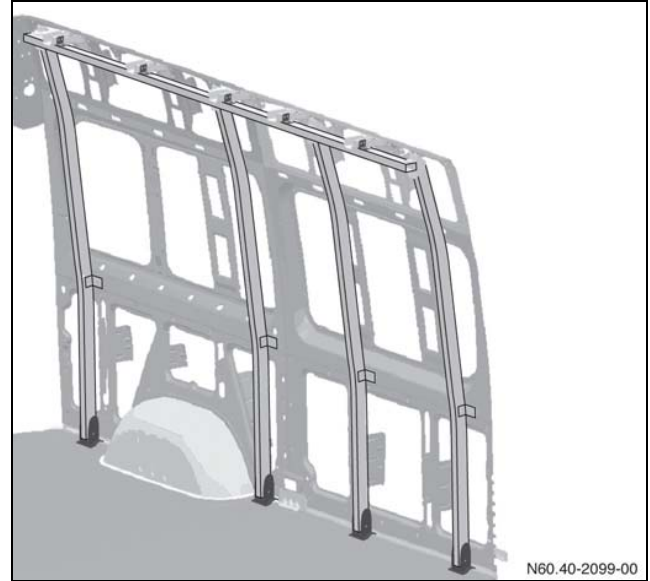

Suggested attachment with ZE6

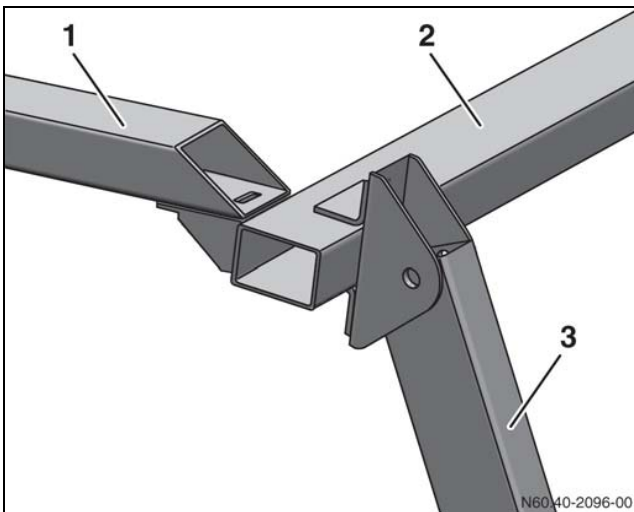

Additional connecting of the longitudinal tubes

- 1 connecting rail
- 2 longitudinal tube
- 3 support

if the first or last support is more than 300mm [12 in] away from each roof arch, the longitudinal tubes must be connected together.

7.6.5. Loading cranes

The size of the crane must be selected in accordance with the chassis size.

Loading cranes must be secured on a mounting frame to relieve the load on the frame (→ chapter 8.1) The permissible axle loads must be verified by calculating a weight balance.

The vehicle's stability must be ensured by the body builder. The slewing range of the crane must be limited accordingly.

Loading cranes mounted on vehicles must comply with all applicable accident prevention regulations.

Comply with all legal requirements.

The mounting instructions of the crane manufacturer must be observed.

If additional platform or tipper bodies are mounted, the dimensions of the longitudinal mounting frame member must be taken from the table for platform bodies (→ chapter 8.5) or tipper bodies.

Outriggers must be provided for every loading crane. We recommend using hydraulic supports. The vehicle must not be raised using the outriggers, as this would damage the frame

Loading cranes behind the cab

Loading cranes and outriggers must not impair the function of other equipment.

Mounting frame

- Maximum crane load moment (kN x l) / 25 kNm
- Moment of resistance (W_x) for longitudinal mounting frame members: 45cm^3 / $[2.75\text{ in}^3]$
- Section dimensions of mounting frame longitudinal members (→ chapter 7.2).
- While the crane is in operation, vehicle stability must be ensured by extending outriggers.
- Outriggers extending beyond the vehicle when stationary must be made easily distinguishable by conspicuous colors, reflectors and warning lights.
- The platform length depends on the position and weight of the loading crane and must take into consideration the permissible axle loads.

- The vehicle may only be used on flat, paved roads.
- Due to the vehicle's load distribution, a frame extension may be required.
- If a stronger mounting frame is required than for the body when a loading crane is mounted behind the cab, the loading crane can be secured on a shorter mounting frame (see illustration below). The short chamfered mounting frame must have a length of $L_M > 35\%$ of the wheel base.
- This attachment required approval from SPRINTER ENGINEERING.

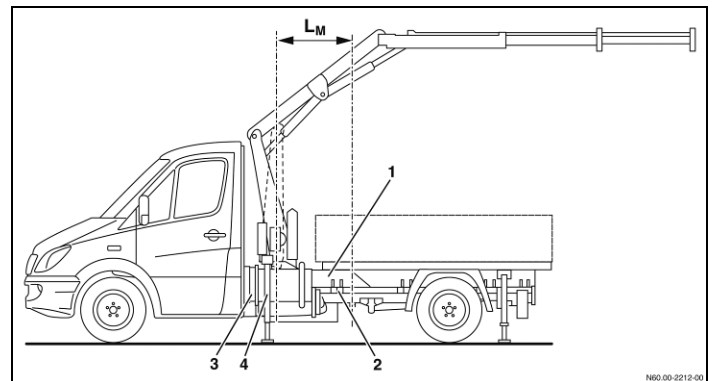

Loading crane

- | | |
|-------|--|
| 1 | Loading crane mounting frame |
| 2 | Body support brackets |
| 3 | Loading crane attachment |
| 4 | Outrigger |
| L_M | Length of loading crane mounting frame |

Loading crane mounted at end of frame

Warning

The minimum front axle load (→ chapter 4) must be complied with in all load states. Otherwise, adequate driving stability is no longer guaranteed.

- Loading cranes must be secured to a mounting frame made of steel
- Maximum crane load moment (kN x l): 25 kNm
18,439ftlbs
- Moment of resistance (W_x) for longitudinal mounting frame members: 45 cm^3 $[2.75\text{ in}^3]$
- Section dimensions of mounting frame longitudinal members (→ chapter 7.2).
- While the crane is in operation, vehicle stability must be ensured by using extending outriggers.

7.6.6. Loading tailgate (lifting platform)

Please consult SPRINTER ENGINEERING if you intend to retrofit a lifting platform to SPRINTER models. If a lifting platform is being fitted, observe the following:

An auxiliary battery (Option E28) must be fitted if an electro-hydraulic lifting platform is fitted. The deep discharge battery with higher capacity (Option ED4) is highly recommended.

- Lifting platforms must comply with all applicable legal requirements
- The permissible rear axle load must not be exceeded
- The minimum front axle load must be complied with in all load states.
- Vehicle stability must be ensured by the body builder in all operating states.
- Calculate the vehicle's load distribution. This calculation must take all special equipment into consideration.
- If necessary, shorten the body length and the rear chassis overhang accordingly (Chassis Cab series).
- We recommend the use of only hydraulic supports.
- Maximum load distance 600mm [24 inches] relative to the standard rear portal / standard rear cross member.
- Vehicle stability when loading and unloading the vehicle must be ensured by the user.
- The maximum lifting force must not be exceeded.

Lifting platform attachment

The attachment of a lifting platform must be designed as described in the "Attachment to the rear frame section" (→ chapter 7.2.2).

Additional torque support must be provided by means of at least two bolted connections fitted with spacer bushings (e.g. on the mounting frame).

- Extend the mounting frame as far forwards as possible and attach it with a non-positive connection to the chassis frame.
- No mounting frame is required on vehicles with a standard Cargo van body.

If modifications are required to the under ride guard due to the attachment of a lifting platform, the strength and bending strength of the under ride guard must not be changed. The vehicle must not be raised using the outriggers, as this would damage the frame.

Model	Wheel base [in]	Maximum lifting force (kN)/[lbs]		Minimum dimension of mounting frame longitudinal member (mm)/[in]
		Chassis Cab	Cargo	
SPRINTER 2500 8550 GVWR	144	-	5 / [1124]	80x45x3 / [3.1 x 1.8 x 1/8]
	170	-	5 / [1124]	80x45x3 / [3.1 x 1.8 x 1/8]
	144	-	5 / [1124]	80x45x3 / [3.1 x 1.8 x 1/8]
	170	-	5 / [1124]	80x45x3 / [3.1 x 1.8 x 1/8]
SPRINTER 3500 9990 & 11030 GVWR	144	10 / [2248]	5 / [1124]	120x50x4 / [4.75 x 2 x 5/32]
	170	10 / [2248]	5 / [1124]	120x50x4 / [4.75 x 2 x 5/32]

7.6.7. Trailer hitch

- We recommend the use of trailer hitches that have been approved by MB and attached to the special mounting points on the body shell (rear longitudinal member)
- Access to the spare wheel must be guaranteed if a trailer hitch with non-detachable ball neck is fitted (especially with a fully laden vehicle).
- Fitting the trailer hitch must comply with all applicable regulations.

Never attach a trailer hitch to the end cross member of the frame.

Information is available from your authorized SPRINTER dealer.

Clearance dimensions, trailer hitch

The height of the trailer hitch above the ground must be between 300mm [11.75 in] and 450mm [18 in] when the vehicle is laden to the permissible gross vehicle weight.

The reliable operation of the hitch must not be impaired.

Do not install an open-jaw hitch fitted to the front of the vehicle.

The specified clearances must be maintained.

Warning

If the towing vehicle is unladen, only an unladen trailer may be towed. If the trailer hitches have removable ball hitches, the operating instructions must be supplied in the vehicle and they must refer to the special features and operation of the hitch.

Attachment of the trailer hitch

Only secure trailer hitches and mounting plates to the special mounting points on the body shell (rear longitudinal member). In addition, Cargo vans require an additional attachment as support on the rear cross member of the vehicle frame.

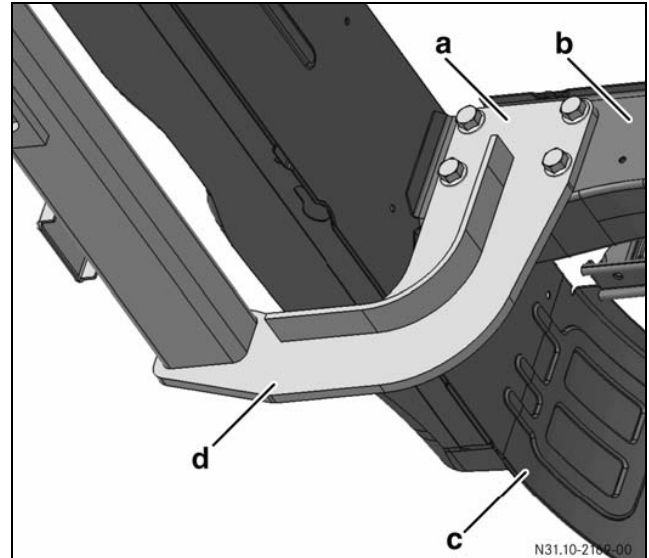

Inside view

- a Attachment of mounting plate to the longitudinal frame member
- b Lower chord of the longitudinal frame member
- c End frame cross member
- d Mounting plate for the trailer hitch

If the frame needs extending, spacer bushings must be fitted to the frame to attach the mounting plate or the rear cross member. They may lead to a reduction in the towing weight or the tongue weight.

You will find whole patterns with dimensions for securing the trailer hitch in the "Technical details" section.

Depending on the model series, the following optional equipment is available as an option from the factory to retrofit trailer hitches:

Chassis Cab

Option	Description
V08	Complete trailer tow group
E58	Complete trailer hitch wiring with 7 pin connector included at rear cross member

Cargo / Passenger Van

Option	Description
V08	Complete trailer tow group

Note:

Option V08 can not be ordered with rear step bumper W73.

7.6.8. Underride guard

If an under ride guard is required, it must comply with applicable legal requirements and its design drawings submitted by the body builder. The under ride guard must be mounted as far back as possible.

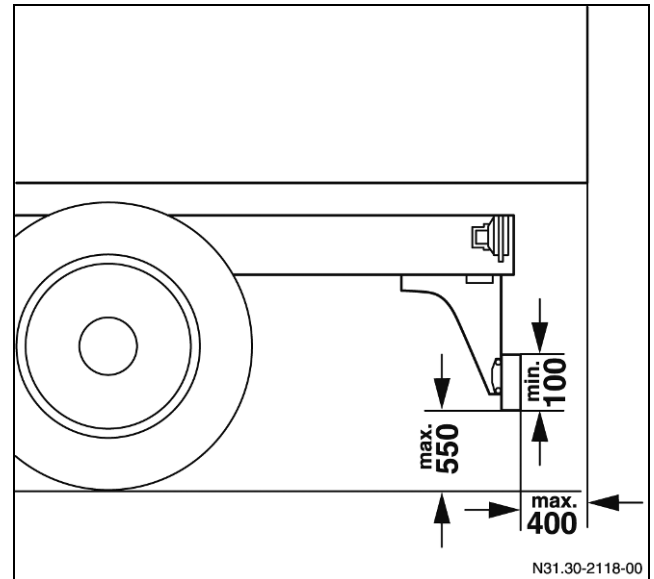
Side view Dimensions

- Maximum height of under ride guard (unladen vehicle) above road surface: 550mm [22 in]
- Width:
 - Maximum = width of rear axle (outer tire edge)
 - Minimum = width of rear axle less 100mm [4 in] on each side. The decisive factor is the widest axle
- The cross member must have a section height of at least 4 in.
- Edge radius at least 2.5mm [0.1 in].

Modification to the underride guard

If the under ride guard needs to be repositioned due to the overhang extension, the attachment must be the same as that of the original vehicle. If modifications are required to the under ride guard (e.g. due to the attachment of a lifting platform), the strength and bending strength of the under ride guard must not be modified. Any modifications to the under ride guard must comply with all applicable regulations.

8. Design of bodies

This section contains information concerning the body to be produced by the body manufacturer.

8.1. Mounting frame

All bodies require a mounting frame or a substructure that assumes the function of a mounting frame to ensure a reliable connection between the chassis and the body (except for self-supporting bodies and mounting frames acting as floor assemblies)

Attachment to the frame must run along the frame using the body support brackets attached to the frame at the factory (→ chapter [8.1.4](#)).

Note:

All available body mounts and their attachment points must be used.

8.1.1. Material quality

Required moment of resistance¹ of mounting frame:

Up to maximum standard Wheelbase	30 cm ³ / 1.8 in ³
Over maximum standard Wheelbase	> 34.5 cm ³ / 2.1 in ³

¹ Each individual mounting frame longitudinal member must have the moment of resistance specified here.

Material quality of specified mounting frame made of steel:

- Mounting frame with bracket mounting (non-positive) = H240LA or S235JRG2

- For H240LA or S235JRG2 steels complying with the DIN EN standard, analogous materials complying with the US SAE/ASTMJ403/J412/J413 standards.

Material quality of specified frame made of steel

Material	Tensile Strength (N/mm ²) Yield Strength (N/mm ²)
H240LA (DIN EN 10268-1.0480)	350-45 260-340
S235JRG2 (DIN EN 10025-1.0038)	340-510 >235

- If high-strength steel is used for the mounting frames, their strength must be at least equivalent to steel mounting frames
- If aluminum mounting frames are used, their strength must be equivalent to steel mounting frames. Observe the specifications of the aluminum manufacturer.

8.1.2. Design

General

The mounting frame cross members must be located above the chassis frame cross members.

The mounting frame longitudinal members must extend as far towards the front of the vehicle as possible, to reinforce the point behind the cab which is critical with regard to bending stress, as well as to prevent vibration problems.

The body must have a torsion-free attachment to the body support brackets on the longitudinal frame member.

Place the vehicle on a flat, horizontal surface before mounting the body.

If very high longitudinal members are required or if the height of the frame needs to be small, the U-section can be designed as follows if the connections are non-positive:

- closed off like a box
- nested (inside overlapping U-section), or
- nested with an overlapping U-section

This increases the moment of resistance and torsional stability

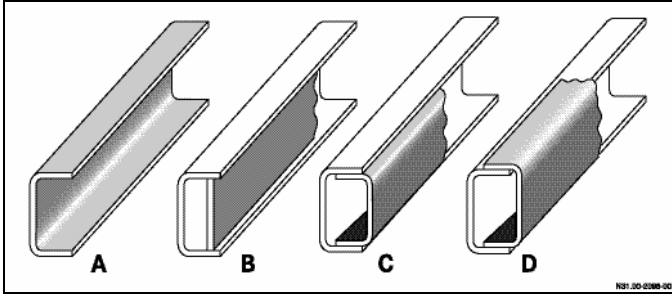

Frame profile

- A Open U-section
- B Closed U-section
- C Inside overlapping U-section
- D Overlapping U-section

Mounting frame with offset frame

On vehicles with a pinched frame (permissible gross vehicle weight 11,030 lbs), the longitudinal mounting frame members can run continuously in a straight line.

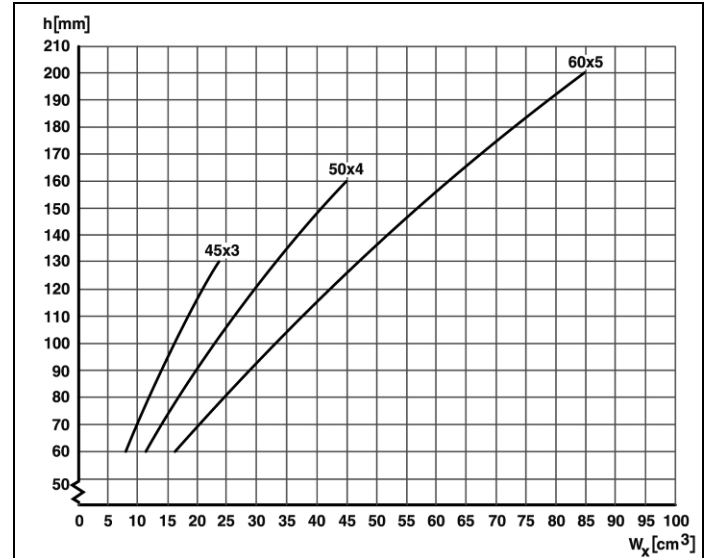

Longitudinal member dimensioning

h : Section height in mm
 W_x : Moment of resistance in cm³

8.1.3. Section dimensions / dimensioning

For the longitudinal members, use flanged U-sections or commercially available U-sections for vehicle design (not rolled steel sections). Box sections are also permitted as longitudinal member section.

The dimensions of the longitudinal members are a function of the moment of resistance (W_x) required for the body and the chassis.

If more than one body is mounted on the same chassis (e.g. platform and lifting platform), the larger of the specified moments of resistance must be taken to determine the mounting frame.

The specified moments of resistance and section dimensions refer to longitudinal frame members subjected to identical loads on both sides.

Please refer to the table below for the section dimensions of mounting frame longitudinal members (open section).

The mounting frame and the chassis frame should have approximately the same flange with.

8.1.4. Attachment to the frame

All body support brackets fitted at the factory must be used for attaching bodies to the vehicle frame. The brackets are located on the longitudinal frame members.

The minimum distance between the body and the cab must be >50mm [2 inches]. Single rear wheel SPRINTER Chassis Cab are not available in the U.S or Canada and is for illustration purposes only.

If prefabricated mounting frames are used, the production tolerances of the chassis frame with (maximum +6/-3mm) [+0.24/-0.12 in] must be taken into consideration.

The positions for the body support brackets are indicated in the 2D drawings depending on the model series.

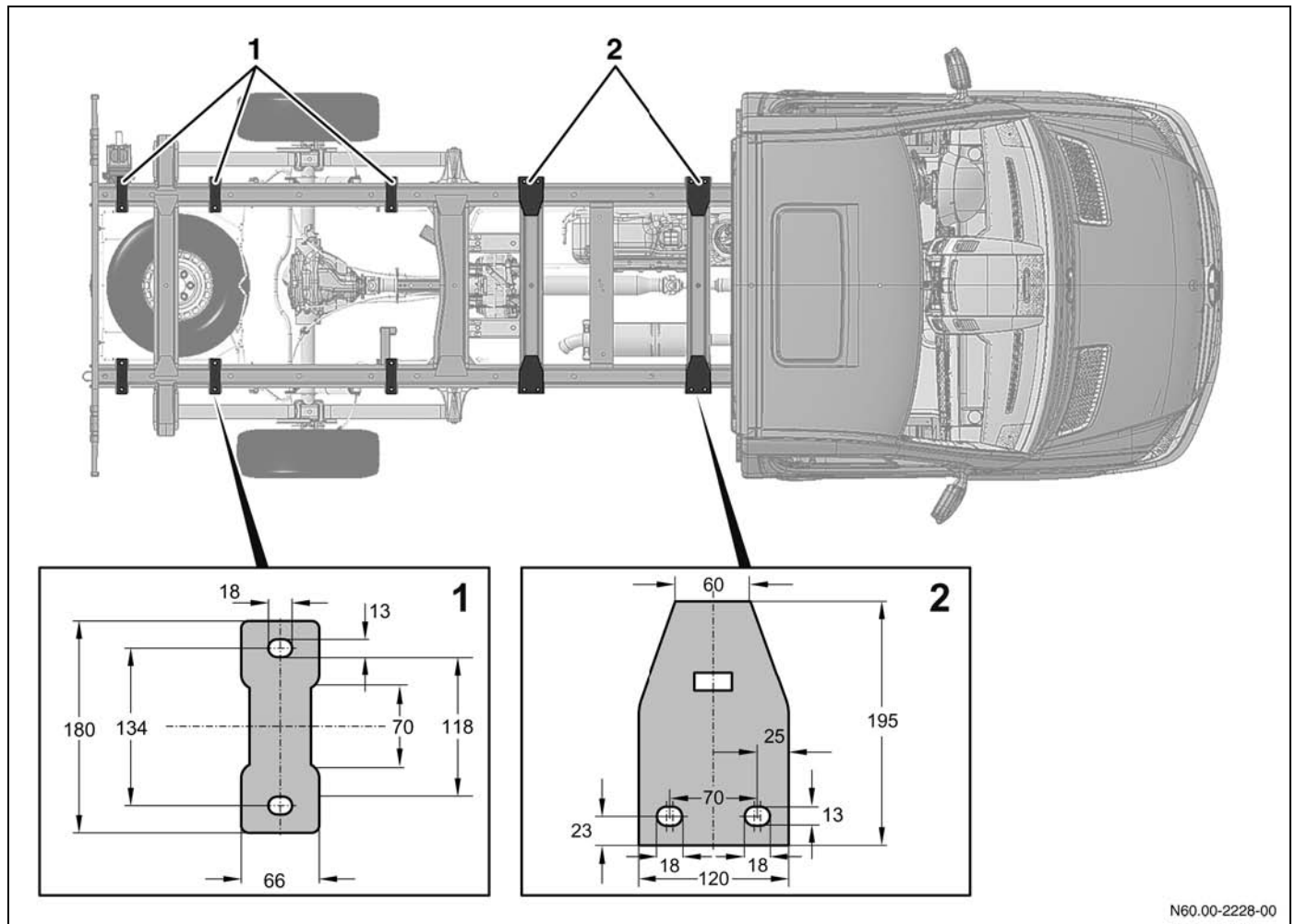

Types of frame fastening points (mm)

Note:

All available body mounts and there attachment points must be used.

Additional body support brackets

If it is necessary to fit additional body support brackets, contact SPRINTER ENGINEERING for directives (→ chapter 2.7).

The body support brackets must be attached using two bolts for each body support bracket.

Attachment of the body support brackets

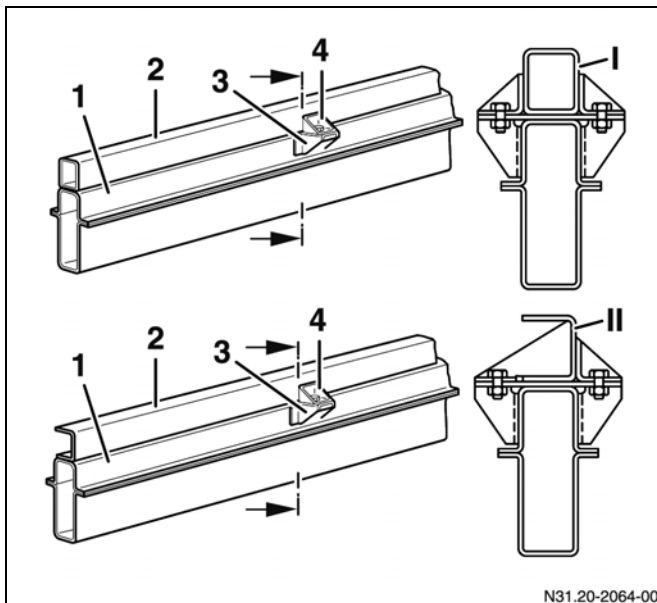

Example of a body bracket design

- I Box section
- II U-section
- 1 Chassis frame
- 2 Mounting frame
- 3 Standard mounting bracket
- 4 Bracket

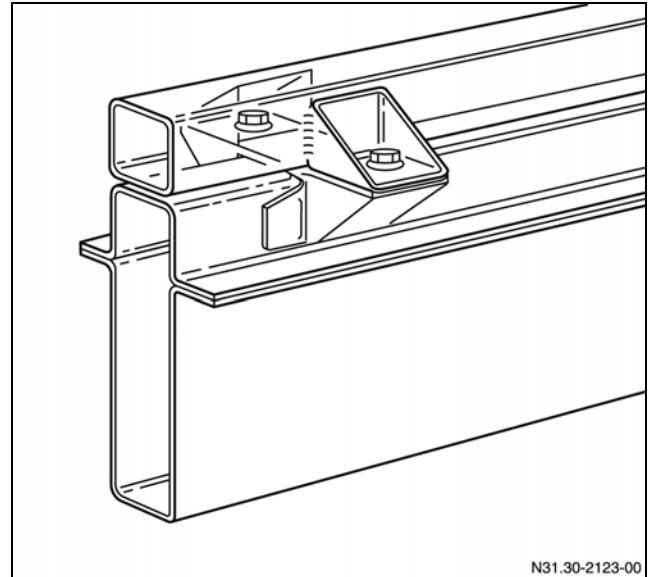

Attachment to a longitudinal member

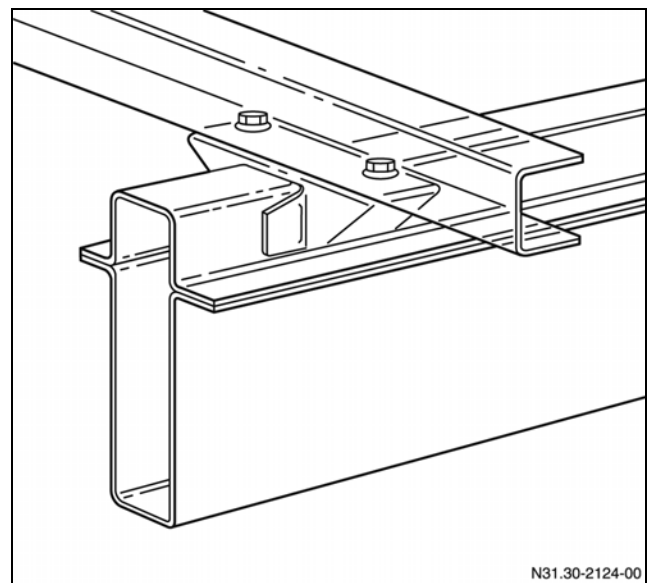

Attachment to a cross member

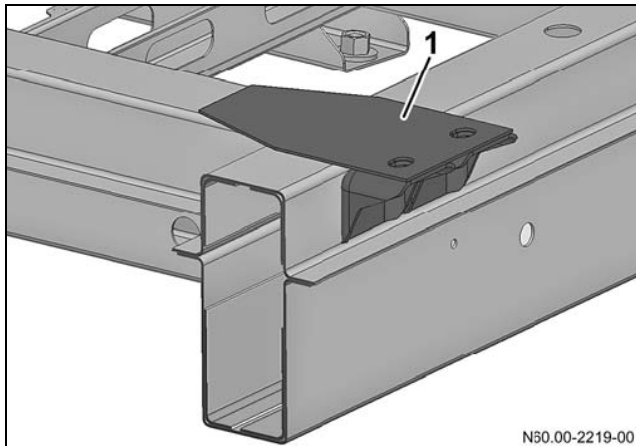

Body bracket with external bolted connection

- 1 Body bracket

Select the number of attachments to ensure sufficient transfer of all longitudinal and lateral forces.

Correct attachment is a decisive factor for:

- vehicle handling and operating safety
- the service life of the chassis frame and the body

Rigid attachment

If the attachment is rigid, the mounting frame longitudinal member must be secured in both longitudinal and transverse directions. This will allow movement of the longitudinal mounting frame member only under specific conditions.

With rigid connections, a double support is required for each longitudinal frame member as depicted in the figure below.

Elastic connection

On rigid bodies (e.g. stiff cargo box, cargo box with cargo lift, refrigeration body etc.), bolted connections locked to prevent loosening and spacer sleeves must be provided at the first and second body brackets. The dimensions of the spacer sleeves must be adequate to ensure that they cannot deform.

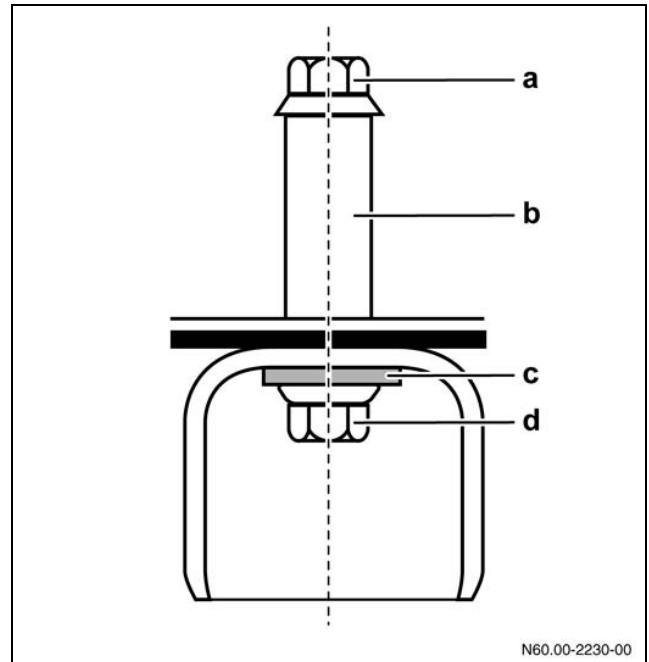

Suggested method for producing a bolted connection, locked to prevent loosening

- a bolt with flange M12 x 90, strength Grade A
- b spacer sleeve 22-13 x 50
- c washer
- d Nut with flange M12, strength Grade A

8.1.5. Mounting frame as floor assembly

A mounting frame with continuous longitudinal members is not required if the body floor assembly can assume the mounting frame function. The longitudinal members can also be integrated in the body. If the mounting frame longitudinal members are intersected by the cross members, the connection between the longitudinal and cross members must be rigid and resistant to torsion and bending.

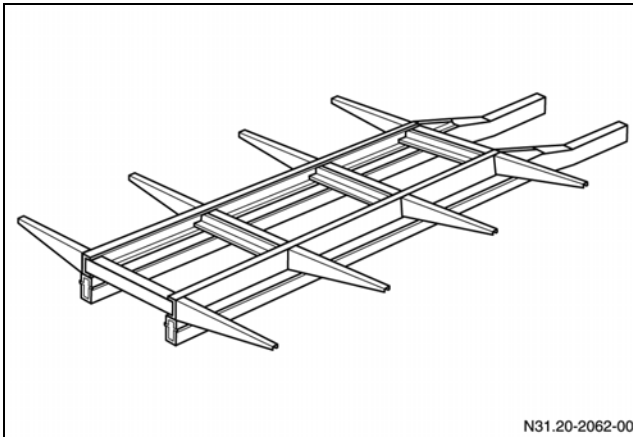

Example of a floor assembly

8.2. Self-supporting bodies

A mounting frame with continuous longitudinal members is not required if the body floor assembly can assume the mounting frame function.

Self-supporting bodies must have the same characteristics as the specified mounting frame. The body floor assembly must have the same rigidity and moment of resistance as a mounting frame.

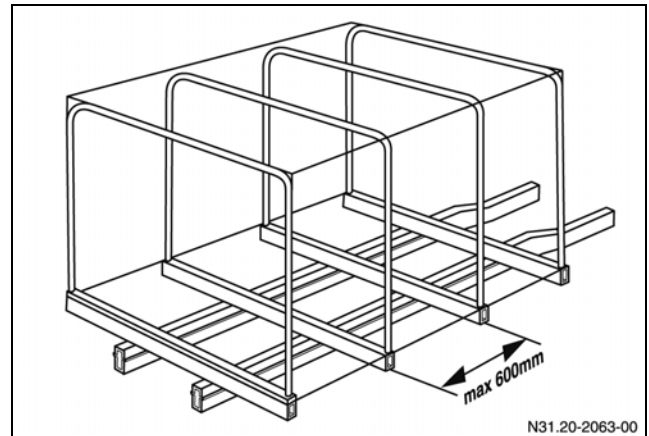

Example of a body design

Spacing max 600mm [24inch]

8.3. Modifications to the interior

8.3.1. Retrofitting additional rear seats

When retrofitting rear seats, it is absolutely essential to keep to the H-point (hip point). You can obtain up-to-date documentation from SPRINTER ENGINEERING.

All applicable FMVSS/CMVSS regulations must be observed.

When re-installing seat belts, the specified bolts must be tightened to the original torque. 37NM / 27.3ftlbs

Warning

If seats other than those fitted at the factory are fitted in conjunction with seat belts available from the factory, only seat belt buckles that are compatible with the belt tongues of the factory-supplied seat belts may be used. Otherwise, the seat belt cannot engage in the seat belt buckle correctly and in the event of an accident occupants may suffer severe injury or death.

Only the components of MB may be used for the installation of safety belts and seat belt buckles.

All applicable regulations relevant to approval (e.g. seat belt buckle position) must be observed when fitting seat belts and seat belt buckles other than those available from the factory.

Warning

Never mount seats on the rear wheel wells. In the event of an accident, if the seats become detached from their anchorages may lead to severe injury or death.

8.4. Modifications to Cargo vans

Floor assembly/side panels

On Cargo vans, the body forms a self-supporting unit with the chassis frame. If body parts are modified or fitted, they must be welded if a bonded connection is not possible. For this reason, windows, roof hatches and vent openings must be mounted in a sturdy frame. The frame must then be joined by a non-positive attachment to other body elements.

Cab rear panel

If there is an opening in the cab rear panel, a sectional frame must be fitted in the opening. The remaining braces and pillars must be reinforced by additional gussets and connected to the sectional frame (e.g. by bonding). Refer also to the "Modifications to cab" section.

Partitions

Partitions in Cargo vans may be totally or partially removed. The following partitions are available as optional equipment from the factory:

Option	Description
D50	Partition, continuous
D51	Partition, continuous with window
D53	Partition, continuous with a sliding window
D62	Provision for retrofitting partition
D64	Partition with sliding door
D93	Omission of partition

You can obtain more information about optional equipment from your authorized SPRINTER dealer, SPRINTER ENGINEERING or in the "Optional equipment" section) (→ chapter 3.9).

Vehicle roof

More information about the roof is contained in the "Cargo van / Passenger van roof" section.

8.5. Platform bodies

To ensure the uniform loading of the chassis frame, the body must be attached to the chassis frame by means of a mounting frame (U-section longitudinal members). If the standard platform is subjected to point loads (e.g. for the transportation of cable drums, coils, etc), the substructure and the platform floor must be reinforced to support the load. Before mounting the body:

- Weigh the chassis and define the body length.
- Reflectors and lights must be mounted on the body to comply with legal requirements per FMVSS/CMVSS regulations.

GVWR	Moment of resistance W_x for each longitudinal member in $\text{cm}^3 / [\text{in}^3]$
11,030 lbs	30 / [1.83]

For the section dimensions of the longitudinal mounting frame member, see the section 8.1.3.

When bodies include attachments which move independently, ensure that there is adequate clearance between the attachments and the basic vehicle, otherwise they may collide with the basic vehicle, resulting in damage.

8.6. Cargo vans

To ensure the uniform loading of the chassis frame, the body must be attached to the chassis frame by means of a mounting frame (U-section longitudinal members).

On rigid bodies such as Cargo vans, the attachments behind the cab must be an elastic connection.

GVWR	Moment of resistance W_x for each longitudinal member in $\text{cm}^3 / [\text{in}^3]$
11,030 lbs	40 / 2.44

8.7. Refrigerated vehicles

Refer also to the following sections;

- “Retrofitting an air-conditioning system” (→ chapter [7.5.1](#))
- “Power take-offs” (→ chapter [7.5.3](#))
- “Attachment to the roof”
- “Retrofitting electrical equipment” (→ chapter [6.4.5](#))

On Cargo vans, easy access to the components of the door mechanism (e.g. guide rails and hinges) must be ensured so as not to hinder possible repair work.

On Cargo vans, the insulation increases the weight of the doors and therefore the load on the hinges, carriages and locking systems.

8.8. Dump bodies

Vehicles and dump bodies must comply with all applicable regulations and laws.

Make sure that you do not exceed the permissible axle loads.

Pivots

- The rear pivot on three-way and rear-end dump bodies must be positioned as close to the rear axle as possible.
- When the side gates or tailgate are folded down, they must not strike against the frame end, the light fittings or the trailer hitch.
- The front pivot must be provided with guide brackets so that the pivots can be guided when the dump body is lowered.

Restraining facilities

- Comply with all applicable laws and regulations
- Fit a support (folding support) to prevent the dump body from lowering
- Secure operating devices against accidental operation
- Connect a “dump body” indicator lamp to provide a visual warning that the dump body has not folded back completely (in driving position)

Lifting press

- The press carrier is attached to cross members in the mounting frame.
- The cross members of the mounting frame and the chassis must be placed on top of each other as far as possible forward.
- On three-way dump bodies, the application point of the lifting press must be in front of the center of gravity of the body and the payload.

Mounting frame

If chassis are provided with dump bodies, the mounting frame must have the correct dimensions to support the high loads to which the vehicle will be subjected.

Observe the following points:

- Attach the mounting frame to the body support brackets as described in the "Attachment to the frame" (→ chapter [7.2.2](#)).
- Make sure that the steel longitudinal and cross members have the correct dimensions.
- Close off the rear area of the mounting frame towards the Cargo van and, if necessary, reinforce the mounting frame by installing a diagonal cross or by taking other appropriate measures.

Vehicles with dump bodies can only be used under normal operating conditions. If the vehicle is to be used in heavy-duty operating conditions, we recommend that you contact SPRINTER ENGINEERING (→ chapter [2.7](#)).

GVWR	Moment of resistance Wx for each longitudinal member in cm ³ /[in ³]
11,030 lbs	40 / [2.44]

8.9. Rescue vehicles

Vehicles with bodies for rescue or recovery equipment must be attached with mounting frames of adequate dimensions. In addition, the bodies must be fitted with two rigid connections on each longitudinal frame member.

Refer to the "Winches" section for information on attaching winches.

Also observe the "Side under ride guards"

8.10. Torsional rigidity of body types

The bodies and mounting frames for torsionally rigid bodies (e.g. municipal vehicles, fire-brigade Cargo vans or street-cleaning vehicles) must be attached by means of elastic elements at the front of the frame. The body support brackets fitted at the factory must be used.

If required, the mounting frame must be additionally reinforced at the rear by fitting a diagonal cross.

Refer also to the "Retrofitting electrical equipment" section (→ chapter [4.6.2](#)).

8.11. RV Conversion

Prior to conversion in an RV, please ensure the following important requirements:

- All applicable legal requirements are observed
- All applicable requirements for interior design and RV equipment are fulfilled
- Easy access to the components of the door mechanism (e.g. guide rails and hinges) must be retained so as not to hinder possible repair work.

Particular attention must be paid to the following sections of the body / equipment mounting directives:

- Dimensions and weights (→ chapter 4)
- Instructions on modifications to the basic vehicle
- Electrics/electronics (→ chapter 6)
- Mudguards and wheel wells (→ chapter 7.2.6)

Modifications of conversions to standard vehicles (e.g. the installation of a raised roof) may invalidate the certificate and warranty. Prior to converting a SPRINTER into an RV consult with SPRINTER ENGINEERING (→ chapter 2.7).

Never exceed the center of gravity limits.

We recommend fitting an additional anti-roll bar on the rear axle. This is available from the factory as optional equipment under Option V50. (→ chapter 3.9).

More information on electrics and additional equipment is contained in the “electrics/electronics” (→ chapter 6) and “Additional equipment” sections (→ chapter 7.5).

Warning

If the fuel filler cap is removed or parts are attached to the fuel filler cap, blocking may occur in the event of an accident. Because of this, the protrusion space in the B-pillar may no longer function correctly. On no account should the cap and B-pillar be covered with aftermarket paneling.

Attachment to the frame

- The body must be secured by using support brackets (→ chapter 8.12)

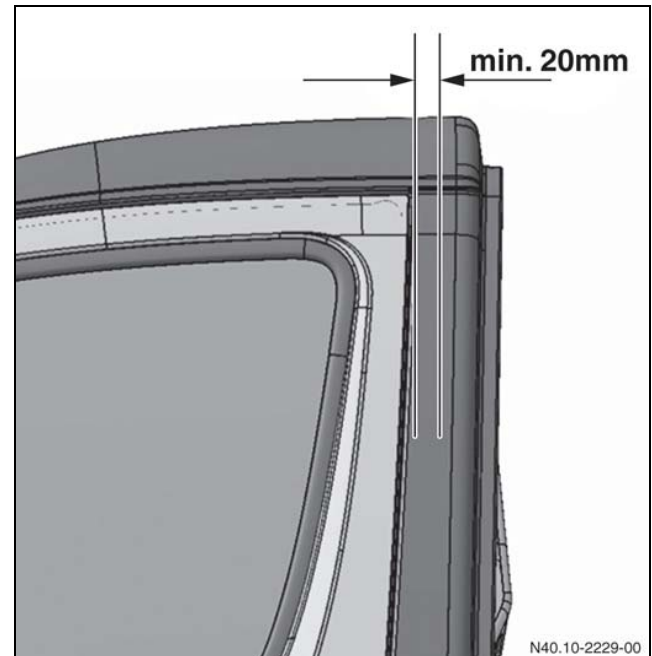

Minimum distance between rear door and integrated body

8.12. Integrated Bodies

A non-positive connection between cab and body is required on vehicles with integrated bodies, e.g. RV's, integrated box bodies etc.

Attachment of cab rear panel to B-pillar (z-axis)

The body side wall must always be connected to the B-pillar. The connection between body and cab must be non-positive.

It must be assured that forces are transmitted between the body and B-pillar. This can be achieved by e.g.:

Variant 1

Attachment of body to B-pillar by means of a plate with $t=2\text{mm}$ [3/32 in] angled at approx. $2 \times 45^\circ$. The plate must be bonded across the entire surface area.

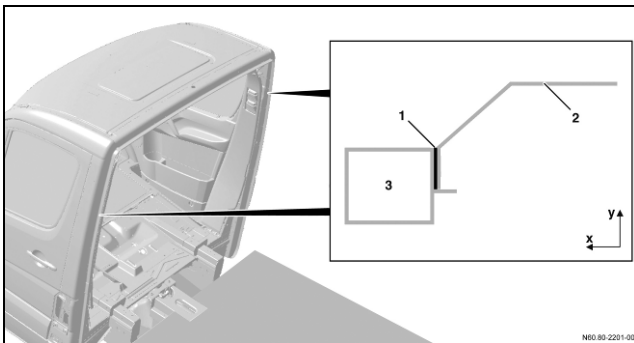

Variant 1: Attachment of body to B-pillar with plate. Picture shows passenger side.

- 1 Bonding flange
- 2 Plate / Bracket
- 3 B-pillar

Variant 2

Attaching the body to the welding flanges of B-pillar with angle pieces.

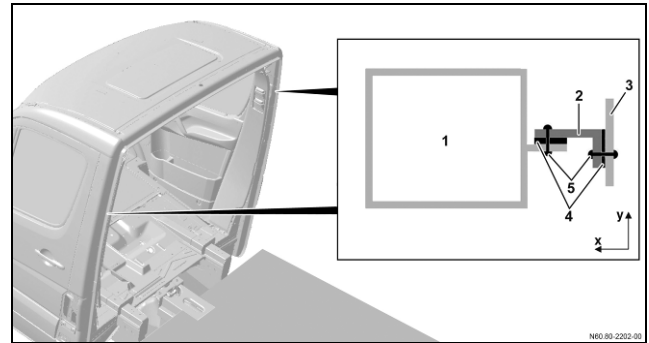

Variant 2: Attachment of body to B-pillar welding flanges with angle pieces. Picture shows passenger side.

Picture shows passenger side.

- 1 B-pillar
- 2 Angle piece
- 3 Front wall of upfitter body
- 4 Bonding flange
- 5 Rivet

Attachment of cab rear panel to roof bow (B-pillar) (y-axis)

In addition to the connection between body sidewalls and vehicle, it is necessary to form a non-positive connection between body and vehicle in the area of the B-pillar roof bow on vehicle with integrated bodies.

This can be achieved by e.g.

Variant 1

Attachment of body to B-pillar roof bow by means of a plate with $t=2\text{mm}$ [3/32 inch] angled at approx. $2 \times 45^\circ$. The plate must be bonded across its entire surface area.

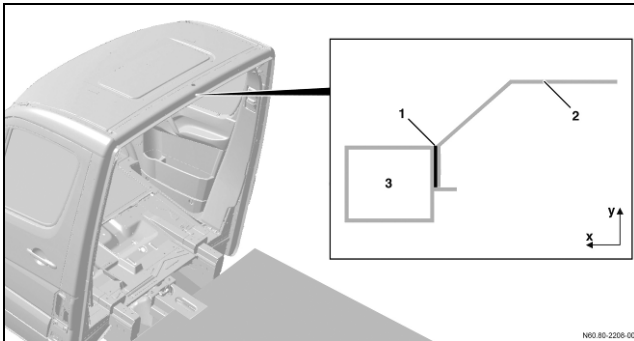

Variant 1: Attachment of body to B-pillar with plate.

- 1 Bonding flange
- 2 Plate / Bracket
- 3 Roof bow (B-pillar)

Variant 2

Attaching the body to weld flange on roof bow with angle pieces

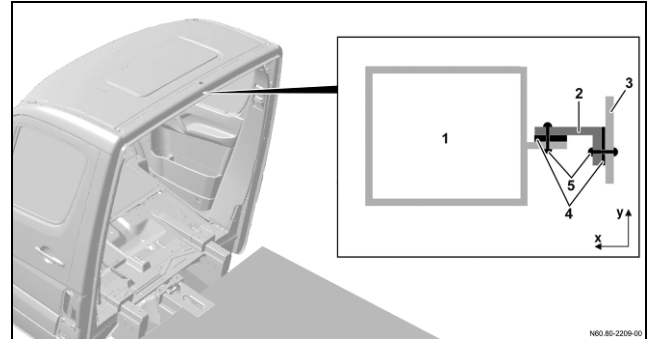

Variant 2: Attachment of body to roof bow welding flanges via angle pieces.

- 1 B-pillar
- 2 Angle piece
- 3 Front wall of upfitter body
- 4 Bonding flange
- 5 Rivet

8.13. Bodies on chassis with lowered roof

Code FA1 “Lowered Roof” is available for partially integrated and alcove bodies on vehicles with Code F28 “Platform with doors.” Code FA1 comprises the following changes from the standard version:

- The height of the roofs is reduced by approx. 70mm.
- The vehicle is cut in the area of the roof / door portal, reinforced by means of bodyshell modifications and the painted in the area of the bodyshell modifications.
- The standard-equipment sun visors and grab handles are mounted in the same position at modified attachment points.
- The headliner can be attached at the previous attachment points, but must be trimmed and adjusted to fit the interior at the front and sides by the body manufacturer.
- The vehicle is fitted with a temporary roof arch for transportation.
- Before the body is erected it is necessary for the body builder manufacturer to install the auxiliary roof frame supplied at the attachment points provided in order to ensure adequate equivalent rigidity. This provides a lowered attachment plane for bodies.

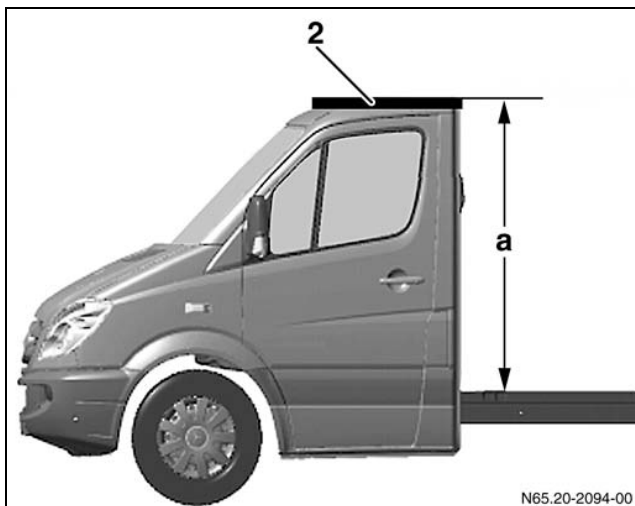

Location of auxiliary roof frame

- 2 Auxiliary roof frame
- a Distance between top edge of longitudinal frame member and top edge of auxiliary roof frame:

3500 lbs.

a = 1,536 mm

8.13.1. Mounting the auxiliary roof frame

The temporary roof arch (1) must be detached before mounting the auxiliary roof frame (2).

The auxiliary roof frame (2) must then be mounted at the points provided using six M10 x 20 10.9 hexalobular bolts (tightening torque 40 Nm +/-2 Nm).

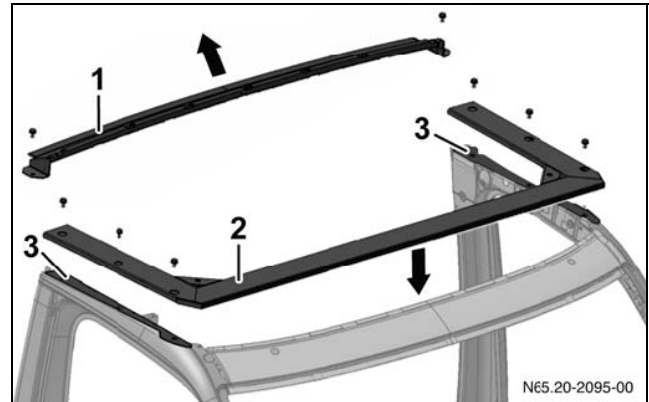

Mounting of auxiliary roof frame

- 1 Transport roof arch
- 2 Auxiliary roof frame
- 3 Cutting area with reinforcements (bodyshell modifications)

8.13.2. Mounting the body on the auxiliary roof frame

The body can be attached to the auxiliary roof frame by

- Bolts
- Rivets
- Adhesive bonding
- Welding

Warning

Holes must not be drilled in the corners of the auxiliary roof frame.

The auxiliary roof frame must not be cut.

The introduction of force to the auxiliary roof frame must occur by way of an area load (line load). Point loads must not be introduced into the auxiliary roof frame.

The load on the auxiliary roof frame while driving must not exceed 100 kg. When the vehicle is stationary, a load of 200 kg is permissible.

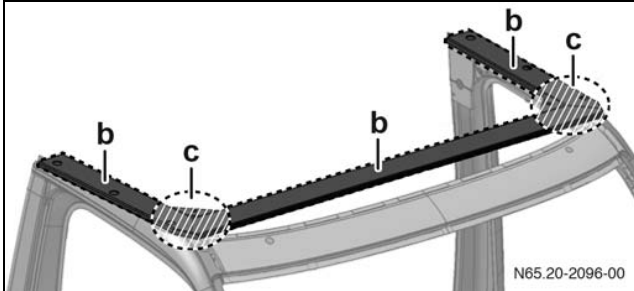

Attachment areas for auxiliary roof frame on vehicles with lowered roof.

- b Attachment area
- c No drilling allowed

Also observe 5.3 "Corrosion protection measures".
The department responsible will be happy to answer any questions.

9. Calculating the center of gravity

After installation or modification of the equipment, vehicles must be weighed on a scale in two different positions with a secured load appropriate to the area of vehicle applications.

The determined center of gravity must not exceed the specified limiting values (→ chapter 4).

Before the measurement is taken, the tires must be **inflated** to maximum pressure and the vehicle suspension at the front and rear axle must be **locked**.

The axle loads must be weighed when the vehicle is horizontal (Wf_1 and Wr_1) and when one axle is raised by amount "a" (Wf_2 and Wr_2); we recommend $a = 500\text{mm}$ [20 in]. The wheelbase WB_1 (144.3 in or 170.3in) is defined by the vehicle model series (see ordering) or must be measured.

Measurement 1

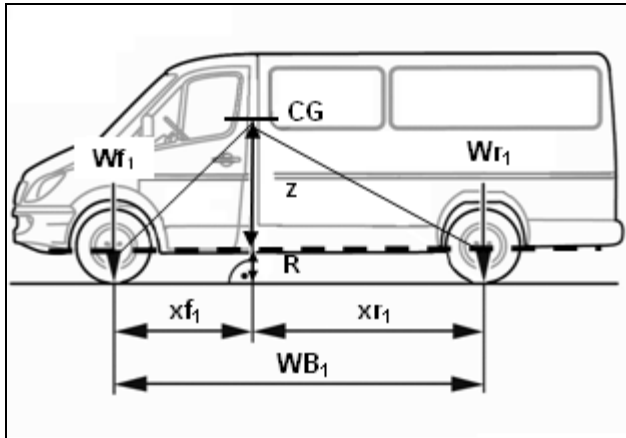

Measurement with vehicle level

Measurement 2

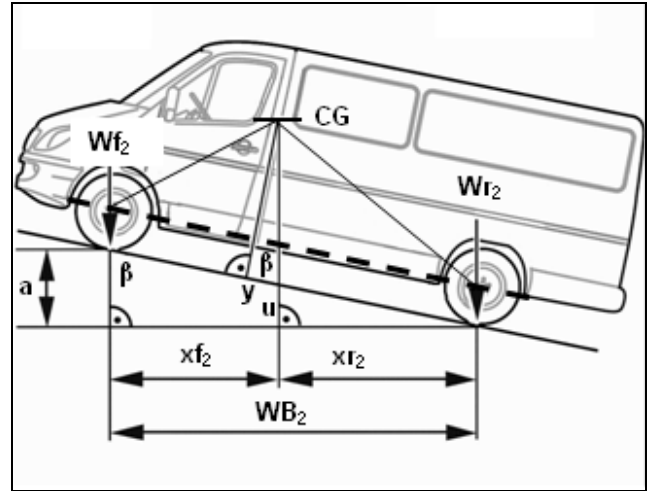

Measurement with axle raised

Definitions:

CG	=	Center of Gravity
Wf	=	weight front
Wr	=	weight rear
W	=	total vehicle weight
WB	=	wheelbase
xf	=	distance from center to front axle
xr	=	distance from center to rear axle
z	=	Center of Gravity height
R	=	static radius height of front and rear wheels

$$z = R + \tan \left[\cos^{-1} \left(\frac{a}{WB_1} \right) \right] \cdot \left(\frac{Wf_1 \cdot WB_1}{W} - \frac{Wf_2 \cdot WB_1}{W} \right)$$

Formula center of gravity