

Diesel Cooker x100

Installation Instructions



Webasto Diesel Cooker X100

Index

	Page
1. Legal notices	2
2. Overview and function	3
3. Installation	4
4. Fuel supply	11
5. Electrical connections	13
6. Exhaust system	14
7. Initial start-up	15
8. Technical details	16

Webasto Diesel Cooker X100

1. Legal notices

Improper installation or repair of a Webasto Diesel Cooker can cause fire or the leakage of deadly carbon monoxide leading to serious injury or death.

To install and repair the Webasto Diesel Cooker you need to have completed a Webasto training course and have the appropriate technical documentation, special tools and special equipment.



NEVER try to install or repair the Webasto Diesel Cooker if you have not completed a Webasto training course, you do not have the necessary technical skills and you do not have technical documentation, tools and equipment available to ensure that you can complete the installation and repair work properly.

ALWAYS carefully follow Webasto installation and repair instructions and note all **WARNINGS**.

Webasto rejects any liability for problems and damage caused by the system being installed by untrained personnel.



Install the Webasto Diesel Cooker only to road vehicles, not to boats.
Use the Webasto Diesel Cooker only for cooking. It is not a heater.



Webasto Diesel Cooker X100

2. Overview and function

2.1 Overview

Figure 1:

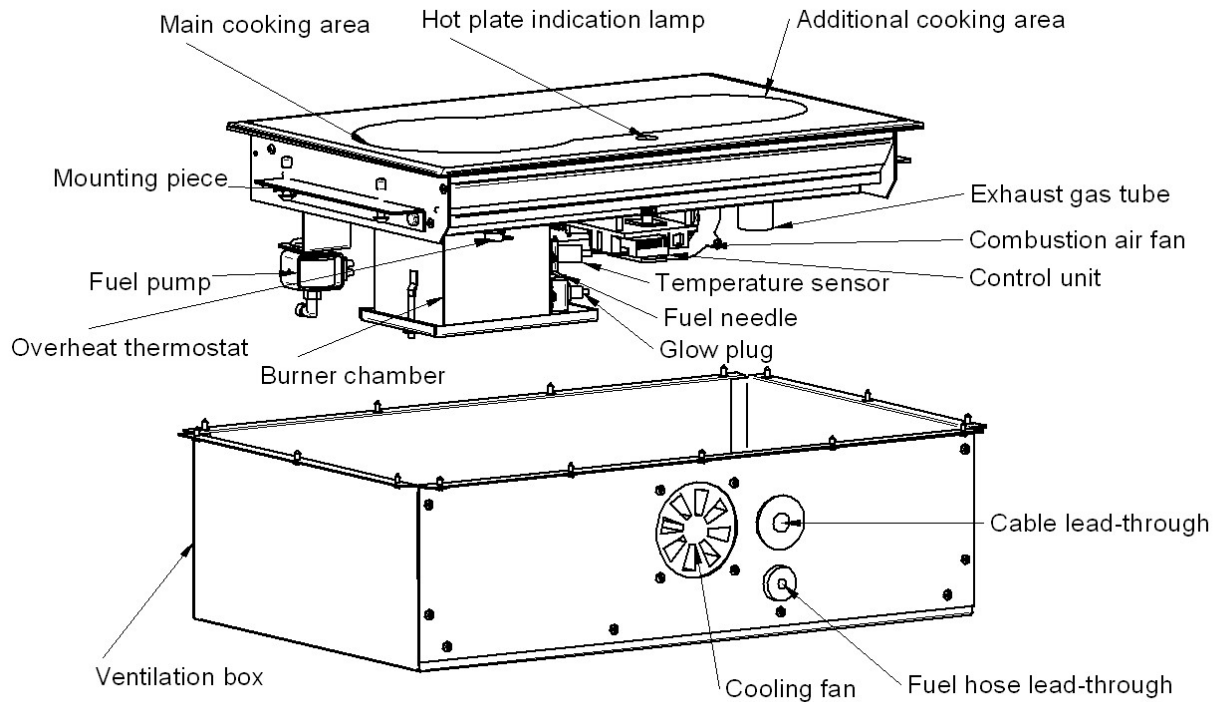

2.2 Function

The Webasto Diesel Cooker X100 is a safe diesel cooker with no open flame. The exhaust gases are led out of the vehicle through the exhaust gas tube, which is inside the cooling air tube. The steam from the exhaust gas will not stay in the vehicle to add humidity.

As the diesel fuel burns, the released heat is transferred to the ceramic plate. The hottest area is on the round plate. Gentler heat is available on the oblong extension. The heat power is steplessly adjustable.

A cooling fan in the ventilation box ensures that the temperature in the mounting space will not rise too high. The warm air is led out through the cooling air tube.

The cooker is ideally suited for cooking and heating of all kinds of food.

The cooker is made entirely of stainless materials.

Webasto Diesel Cooker X100

3. Installation

3.1 Cooker location

When installing a cooker it should be noted that it has to be dismantled for servicing. It is advisable to make the connections in such a way that the device can be easily disconnected for servicing.

There must be at least 20 mm between the cooker and any vertical surface. See figure 2. Make sure that inflammable materials like curtains cannot touch the ceramic plate.

An authorized Webasto service center has to take care of the installation.

3.1.1 Location of pipes, hoses and wires

The power cords and fuel hoses must be protected in places where they are exposed to mechanical damage due to, for example, sharp objects or heat.

Materials which come into contact with parts of the cooker or the coaxial exhaust tube have to resist temperatures of 80 °C.



Do not install the cooker in an area where there may be petrol fumes ⇒ risk of explosion.

Figure 2:

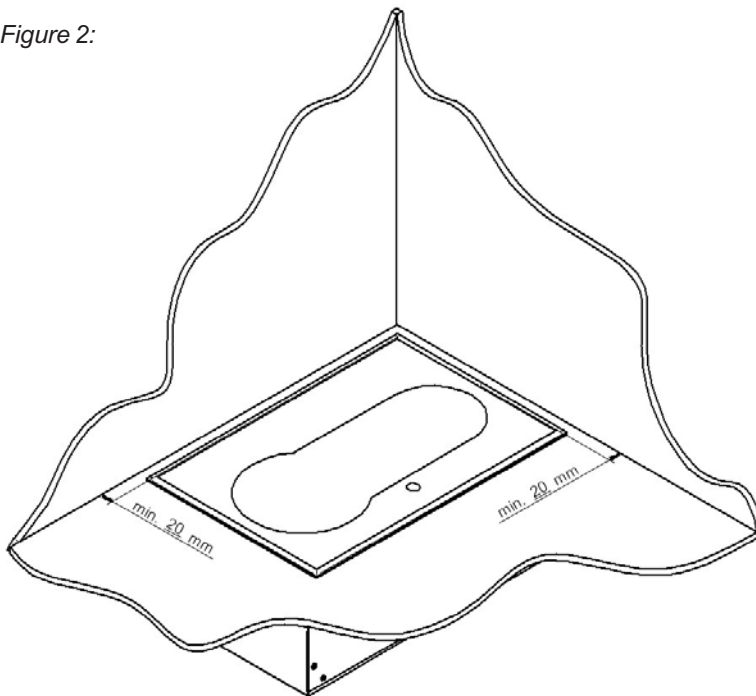

The cooker, exhaust gas tube and all other metal parts must be insulated from the vehicle metal chassis so that in case of an electrical malfunction the voltage is not transferred from the chassis to the cooker or vice versa.

Webasto Diesel Cooker X100

3.2 Installation example

Figure 3:

1. Cooker
2. Operating panel
3. Operating panel cords
4. Power cables
5. 15 A main fuse
6. Battery main switch
7. Fuel hose
8. Fuel filter
9. T-piece for fuel to vehicles return line
10. Exhaust gas tube
11. Cooling air tube

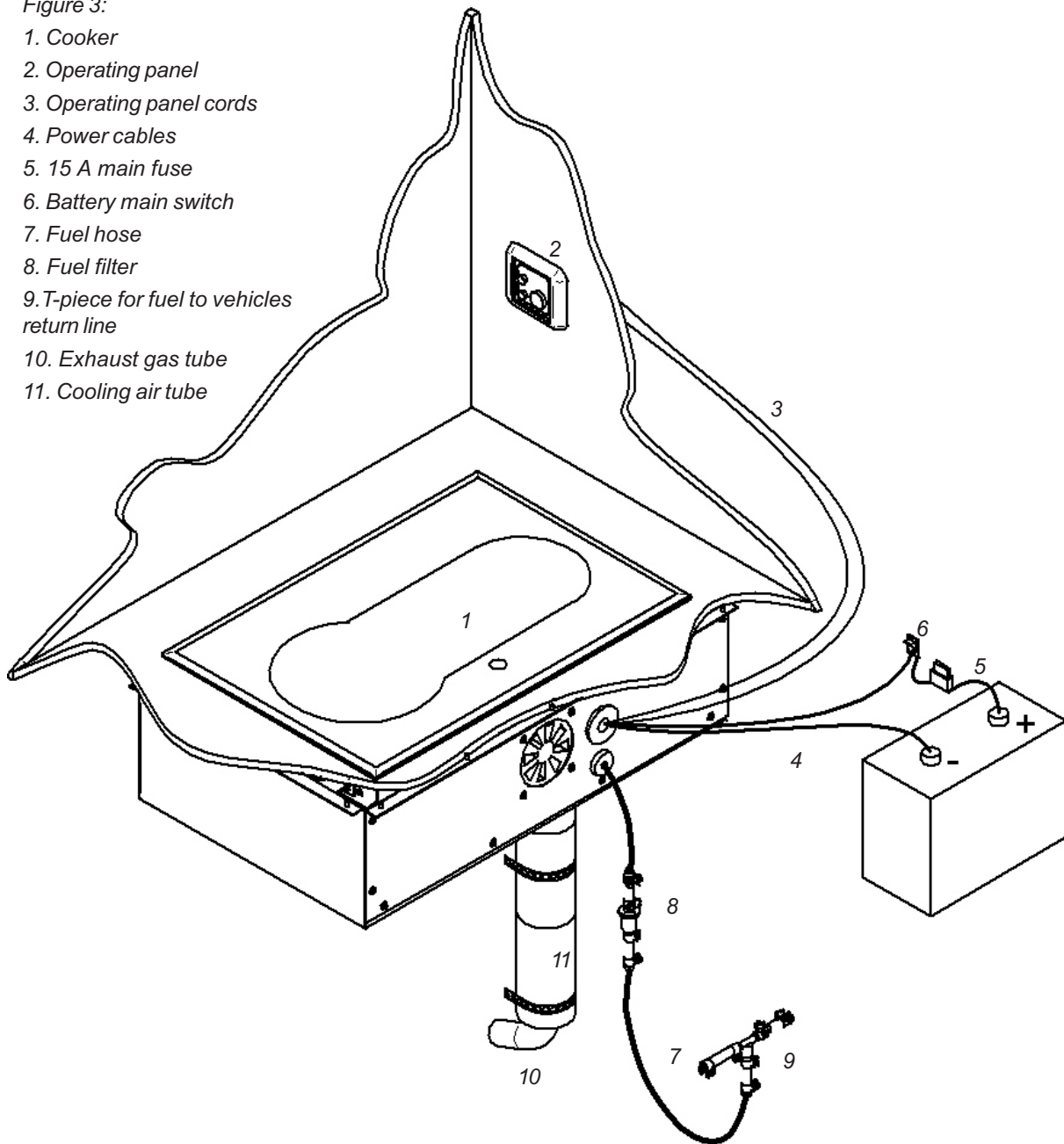

Webasto Diesel Cooker X100

3.3 Replacement air

The cooker needs air for combustion and cooling. There must be sufficient air circulation in the whole vehicle at all times. The place and method of installation must be selected in such a way that the cooker always gets enough replacement air.

There is a cooling fan in the front plate of the ventilation box. There must be at least 200 cm² replacement air opening near the cooling fan in the installation space.



There must be at least a 200 cm² opening for replacement air in the space where the cooker is installed.

The air inlets and outlets must never be covered.



The ventilation box is an important part of the cooker. Never install the cooker without the ventilation box.

Figure 4 A:

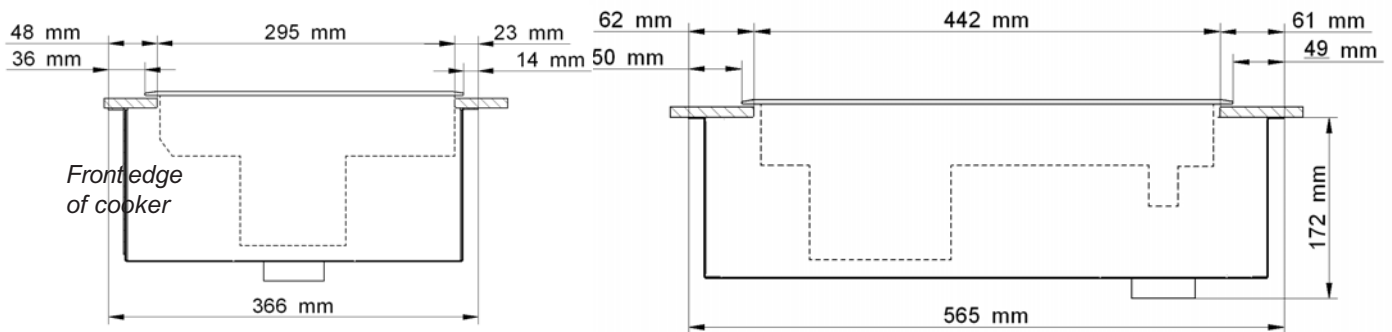

3.4 Installation opening

Saw an installation opening of 295 x 442 mm as shown in figure 4. Do not cut it larger because ceramic plate could be damaged otherwise. Make sure that the cooker is resting with the metal frame on the tabletop.

Note space requirements for ventilation box. The whole ventilation box has to fit into the installation space.

Figure 4B:

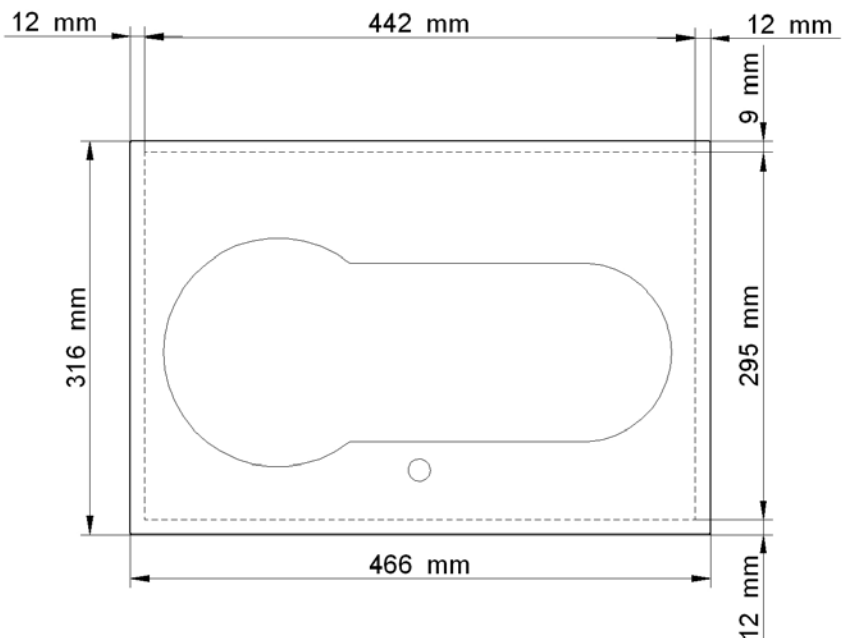

Webasto Diesel Cooker X100

3.5 Mounting the cooker

Figure 5:

Fasten the front plate to the ventilation box with only a few 4.2 x 13 mm screws.

Figure 6:

Place the cooker in the installation opening and attach the mounting pieces to the nuts at the ends of the cooker using the M6 x 12 mm screws. Choose the mounting piece position (A or B) according to the tabletop thickness.

Figure 7:

Then tighten the mounting pieces against the table with M6 x 30 mm screws. Use the locking nuts (M6) and protection plugs (ø 6 mm).

Figure 8:

Connect the fuel hose to the fuel pump and the power cable to the coupling behind the cooker.

Figure 8:

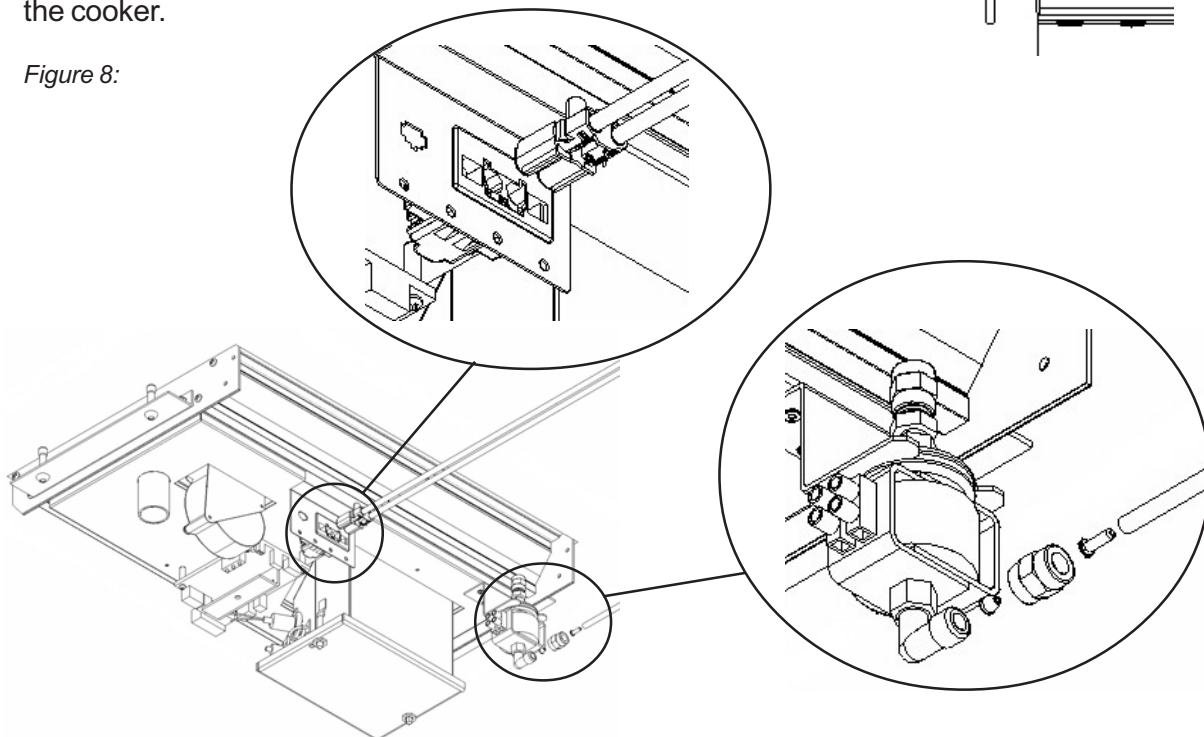

Figure 5:

Figure 6:

Figure 7:

Protection plug

Locking nut

Mounting screw

Webasto Diesel Cooker X100



The fuel couplings must be properly tightened to prevent any air leaks into the hose. Air will cause malfunction of the cooker.

Always check that the coupling surfaces of the fuel hose and the fuel hose itself are clean before tightening them.

Figure 9:

Set the ventilation box around the cooker under the table. Measurements for the ventilation box installation are in figure 4. Fasten only the ventilation box to the tabletop with 10 pcs 3.9 mm screws. Leave the fuel hose and power cable inside the ventilation box.

Figure 9:

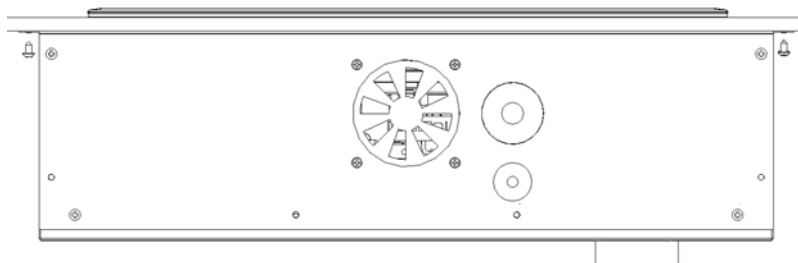

Figure 10:

Take off the front plate of the ventilation box. Fasten the exhaust tube \varnothing 28 mm and cooling air outlet \varnothing 60 mm with hose clamps.

Figure 10:

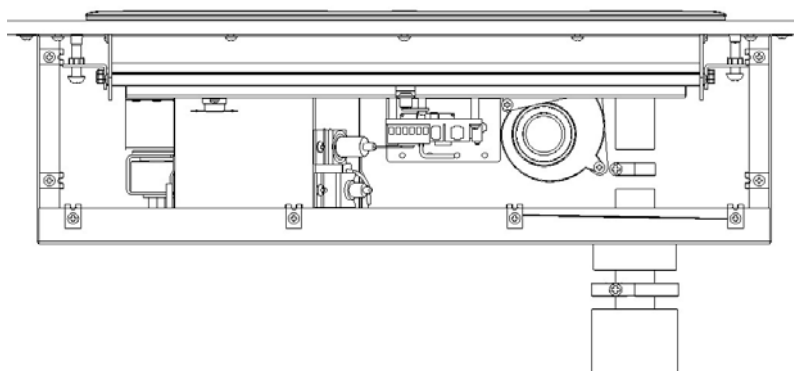
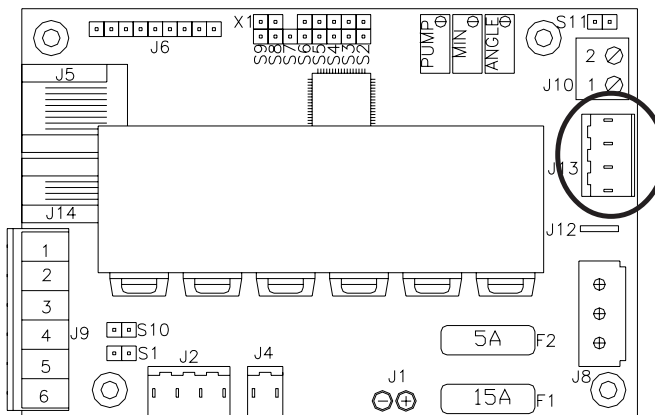

Figure 11:

Connect the cooling fan to the control unit board (connector J13). Ensure that the grooves of the connectors are aligned.

Figure 11:



Webasto Diesel Cooker X100

Figure 12:

Tie up the fuel line, cooling fan cable and power cable with a clip to the other cables of the control unit.

Figure 12:

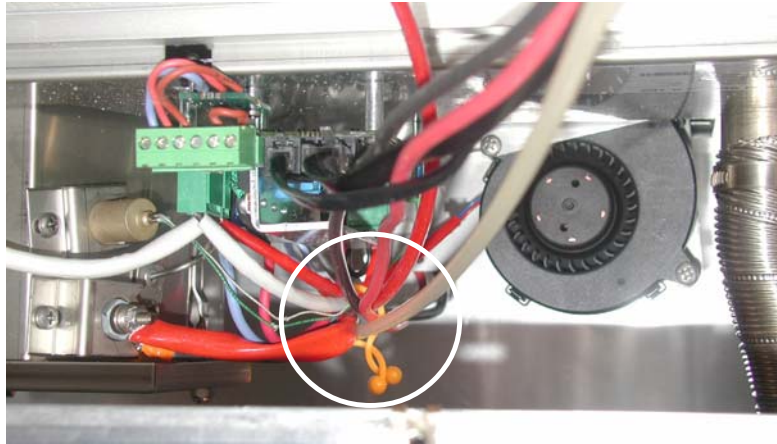

Figure 13:

Plug in the two black cables for the operating panel into the connectors on the control unit.

Figure 13:

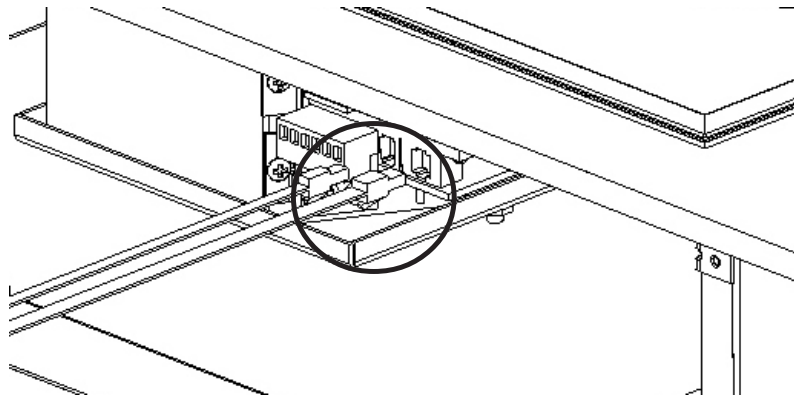

Figure 14:

Carefully feed all cables through the large grommet. Feed the fuel hose through the small grommet. Now fasten the front plate to the ventilation box. Watch the fuel hose and all cables. Those are not allowed to touch hot surfaces such as burner chamber and exhaust tube. Tie cables and fuel line more if needed.

Figure 14:

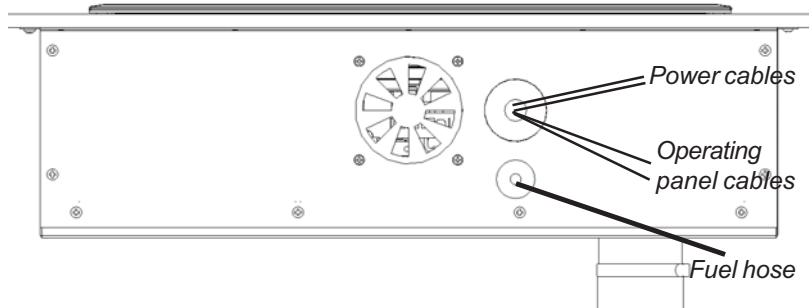
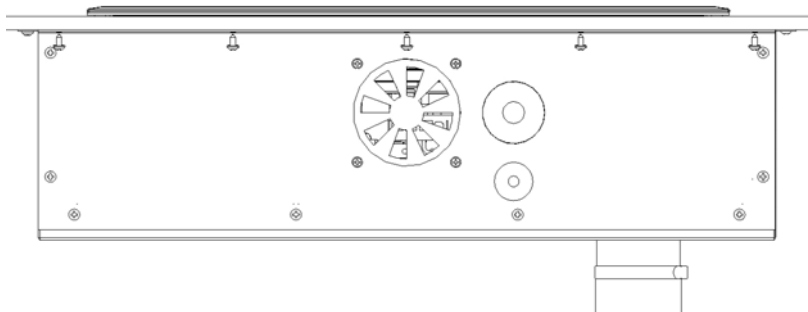

Figure 15:

Fasten the front plate to the tabletop. After that slightly pull at cables and fuel hose to ensure that there is no cable loop inside the ventilation box.

Figure 15:



Webasto Diesel Cooker X100

3.6 Operating panel mounting

3.6.1 Operating panel location

Control panel of the cooker shall be installed in a vertical part of the vehicles' furniture or wall. If mounted horizontally, water and dirt could get into the panel and damage it.

3.6.2 Operating panel installation

Figure 16.

1. To install the operating panel make a $\varnothing 50$ mm hole to the vertical wall.
2. Connect cables to the operating panel.
3. Screw the operating panel with base frame to wall.
4. Clip on the outer frame on to the base frame.



Figure 16:

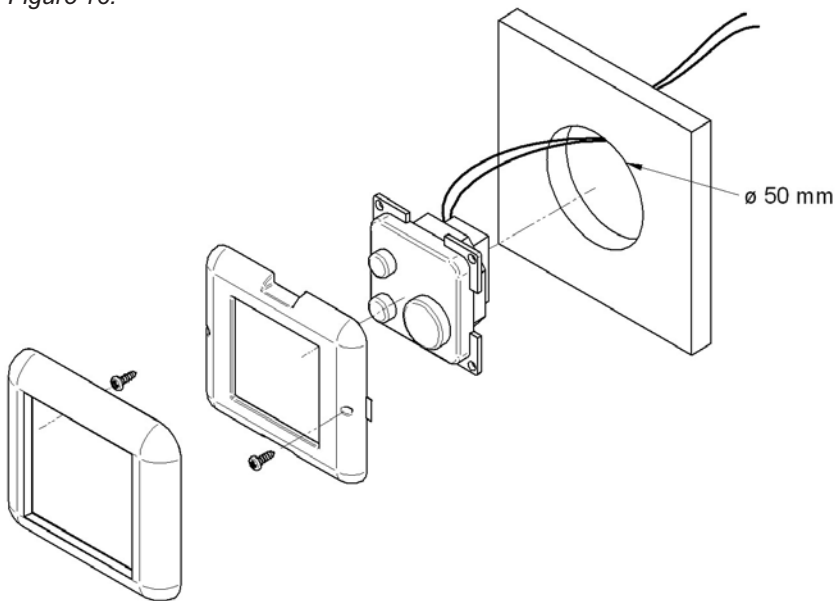

Webasto Diesel Cooker X100

4 Fuel supply



The fuel must not be taken from the fuel hose going to the engine.
The maximum allowed pressure for cooker fuel hose is 2 bar.



The fuel couplings must be properly tightened to prevent any air leaks into the hose. Air will cause malfunction of the unit.
Always check that the coupling surfaces of the fuel hose and the fuel hose itself are clean before tightening them.

4.1 Fuel line

The maximum length of the fuel hose is 8 m. The fuel hose shall always be cut to suitable length for each installation.

The fuel hose must always be equipped with a filter. The fuel filter shall be installed inside the vehicle to prevent freezing in winter. Use a place where it can be easily checked and replaced if necessary.

4.2 Fuel feed

The fuel tank must always be situated below the cooker. The delivery lift of the fuel pump should be less than 1.5 m.

If the delivery height of the fuel pump is above 1.5 m, the fuel feeding needs to be checked and adjusted if necessary. The fuel feeding must also be checked whenever a fuel system part, such as the pump or electronics card, has been replaced.

Fuel feed adjustment must be carried out by an authorized service provider.

4.3 Fuel connection

Cut Mecanyl lines without burr and do not crush them. Do not cut them with side-cutting pliers.

A rubber hose suitable to diesel must be used with all fuel connections.

4.3.1 Fuel extractor

Figure 17.

The fuel can be taken from the vehicle fuel tank or from a separate tank with fuel extractor.

Figure 17:

A) Fuel pickup from the plastic tank via tank fitting. The fitting must be made from metal.

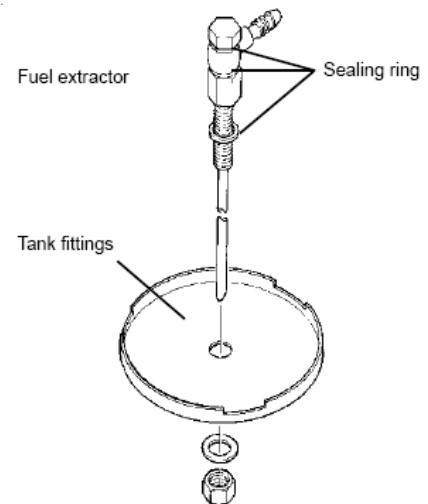

B) Fuel pickup from the plastic tank via tank drain screw.

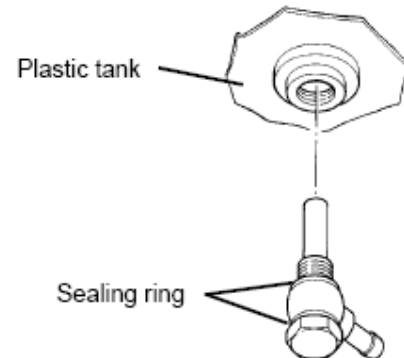

Webasto Diesel Cooker X100

4.3.2 Return line installation

Figure 18.

The fuel hose can be installed with Webasto T-piece to the engine's return line.

4.3.3 Fuel filter

The filter can be installed to a $\varnothing 5$ mm fuel hose. Ensure that the hoses are clear before installation. There must not be any dirt between the pump and the filter in particular, because it will damage the pump.

Install the filter inside the vehicle.

Figure 18: 1. T-piece, 2. Rubber hose $\varnothing 5$ mm, 3. Hose clamp $\varnothing 10$ mm, 4. Rubber hose $\varnothing 8$ mm from engine return line, 5. Hose clamp $\varnothing 12$ mm.

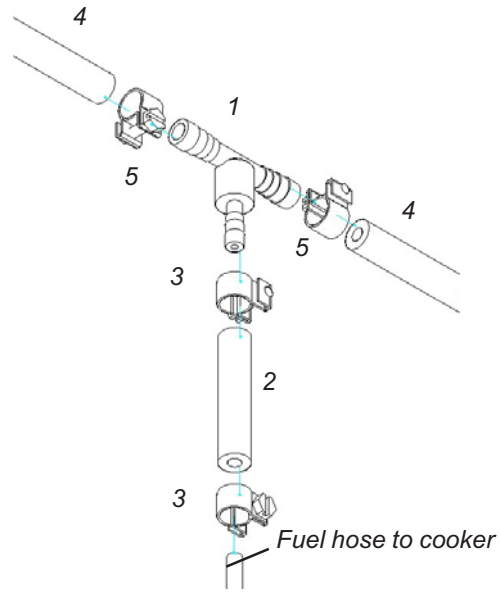
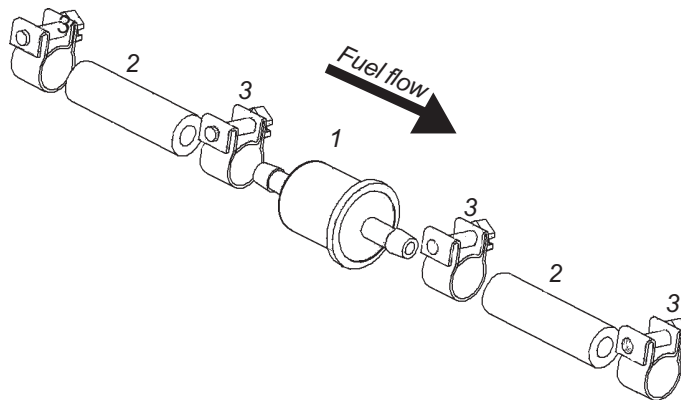

Figure 19:

1. Filter, 2. Rubber hose $\varnothing 5$ mm, 3. Hose clamp $\varnothing 10$ mm.



Webasto Diesel Cooker X100

5 Electrical connections

5.1 Connections of device

The device operates on 12 V DC. Attach the red wire of the power cord to the plus pole of the battery and the black wire to the minus pole.

5.2 Cable Diameter

In order to minimise voltage losses we recommend you make the power cord as short and with as few couplings as possible.

The cross-sectional area of the cable depends on the length of the power cable. See table 1. The maximum cable length is 10 m.

The fast coupling of the cooker is for 4 mm² cable. If cables >4 mm² are needed, the cable connection should be made as close to the cooker as possible (maximum distance 1m).

Figure 20:

1. Main fuse, 2. Main switch, 3. Device quick coupling.

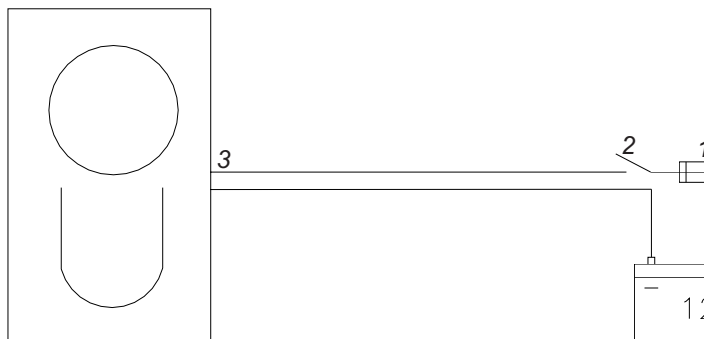

5.3 Battery main switch

A main switch must be installed to the plus wire of the device. Always cut the power from the main switch when the device is not used for a long time.

5.4 Main fuse

A main fuse must be installed in the red plus wire near the battery. See figure 20.

5.5 Voltage

The power consumption of the device is the highest when the glow plug is on during start-up, and so are the voltage losses. During glowing, the voltage must be at least 10.7 V, measured at the quick coupling of the device. See figure 20. If the voltage is below that, starting may fail.

Tabel 1:

Total length of electrical cable (m)	Cross-section of cable (mm ²)
0 - 4	4
4 - 6	6
6 - 10	10



Never cut the power from the device before the run down phase has been completed.

Webasto Diesel Cooker X100

6 Exhaust system

6.1 Exhaust outlet

Air must always be able to flow free past the exhaust gas outlet. Try to install the outlet in such a way that wind can blow past it. The outlet must not be placed in a corner or a confined area when wind pressure may disturb the operation of the device.

6.2 Exhaust installation

Make a $\varnothing 65$ mm lead-through to the floor for exhaust gas and cooling air tubes. Lead both tubes through the hole. Let the cooling air tube stick out min. 10 mm below the vehicles floor. Seal the floor lead-through and cooling air tube with heat resistance silicone. Fasten the exhaust gas tube under the vehicle. Also fix the coaxial hose to the furniture and the floor of the vehicle. Exhaust gas and cooling air tubes must always run downwards to avoid water traps. The minimum bending radius for the exhaust tube is 50 mm.

Figure 21:

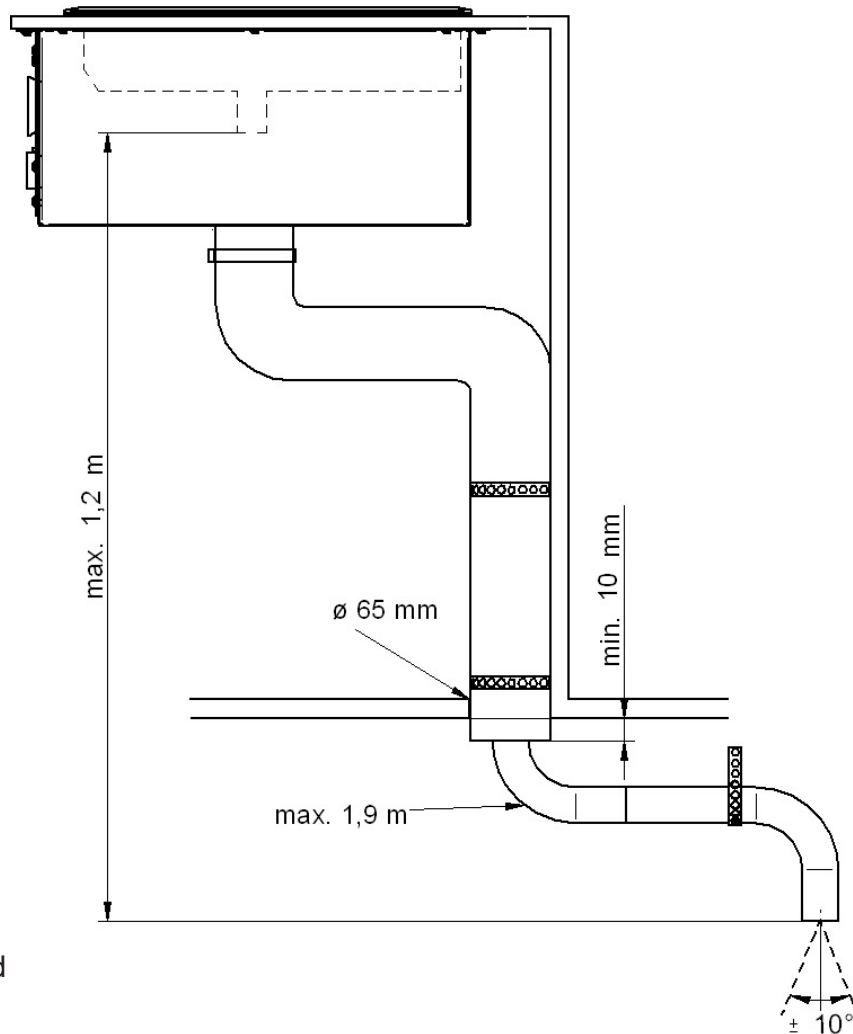

Exhaust gas is hot. Always make sure that there is no inflammable material within 200 mm after the exhaust outlet.

Coaxial tube radiates heat. Beware of the hot surface of the tube during use.



The end of the exhaust gas tube shall point downwards with a tolerance of $\pm 10^\circ$. Make sure that the exhaust outlet ends at the side of the vehicle opposite from the passanger entry door. Also ensure that exhaust gas is blown away from underneath the vehicle.

Webasto Diesel Cooker X100

7 Initial start-up

The cooker starts to heat up automatically when the power switch is turned to ON position. The yellow indicator lamp lights up as soon as the cooker is switched on. The red combustion lamp will light up when a proper combustion has stabilized in the burner, which is 2.5-4 minutes after the start-up.

The cooker will not necessarily start the first try after installation when the fuel hose is empty. Then the red combustion light starts to blink about 4.5 minutes after the start-up. Turn the power switch to OFF position. The device cannot be restarted until both indicator lamps have gone out (run down phase).

Once the indicator lamps have gone out, restart the stove. The red combustion lamp will light up about 2.5-4 minutes after the start-up, when the combustion is normal.

If the fuel line does not fill up during two starts, the cooker will lock itself and both red and yellow lights begin to blink.

Unlocking the diesel cooker:

1. Switch the power ON (lock blinking).
2. Disconnect the main power cord (blinking stops).
3. Reconnect the main power cord (the yellow LED lights up for 1-3 seconds).
4. When the yellow LED has gone out, switch the power OFF.
5. Start cooker normally.

Turn the power switch to OFF position to shut down the stove after test use. The red combustion lamp will keep blinking for about 5 minutes while the cooker is cooling.



The cooker locks itself after two unsuccessful starts.

If the device will not start, even though the fuel has reached the pump, do not try to start it more than twice without checking the cause of the problem.

Webasto Diesel Cooker X100

8 Technical details

Table 2: Technical details of Webasto Diesel Cooker X100.

Fuel	<i>Diesel oil</i>
Operating voltage	<i>12 V DC</i>
Fuel consumption	<i>0.09 - 0.19 l/h (0.074 - 0.156 kg/h)</i>
Heating capacity	<i>0.9 - 1.9 kW</i>
Power consumption	<i>0.3 A, at ignition 8 A.</i>
Dimensions	<i>W 535 x D 343 x H 190 mm Height depends on tabletop thickr</i>
Weight	<i>Approx. 8 kg</i>
Minimum area of the cooling air inlet	<i>200 cm²</i>
Maximum permitted length of the exhaust hose	<i>1.9 m, straight downwards 1.2 m (\varnothing 28 mm and \varnothing 60 mm)</i>
Maximum permitted length of the fuel hose	<i>8 m (\varnothing 5/2 mm)</i>

Webasto Product N.A., Inc.

15083 North Road

Fenton, MI 48430

Technical Assistance Hotline

USA: (800) 555-4518

Canada: (800) 667-8900

WWW.Webasto.US

WWW.techwebasto.com

Part no.: WA490055